

# Classic Fittings Catalog

by Gunnebo Lifting

FITTINGS FOR CHAINS & SLINGS



Smart solutions that meet all demands.  
And deliver integrity in each component.



**GUNNEBO JOHNSON**  
CORPORATION

# **GUNNEBO LIFTING**

## *Your Partner in Safe Lifting*

*The Gunnebo  
Lifting BKLK Ball  
Bearing Swivel  
Self-Locking Hook*



Think Gunnebo Lifting when selecting lifting chain and components. Lifting is our business. Gunnebo Lifting has become known for quality, down to the smallest component, as a result of over 200 years experience, combined with systematic quality control and our own research and development laboratories.

Chain and components are made from quenched and tempered alloy steel. A guarantee for very high strength, low weight, high wear resistance and long life. All Gunnebo Lifting G80 and G100 components are uniformly marked with equivalent chain size, grade and manufacturer's designation for positive identification.



### Quality to International Standards

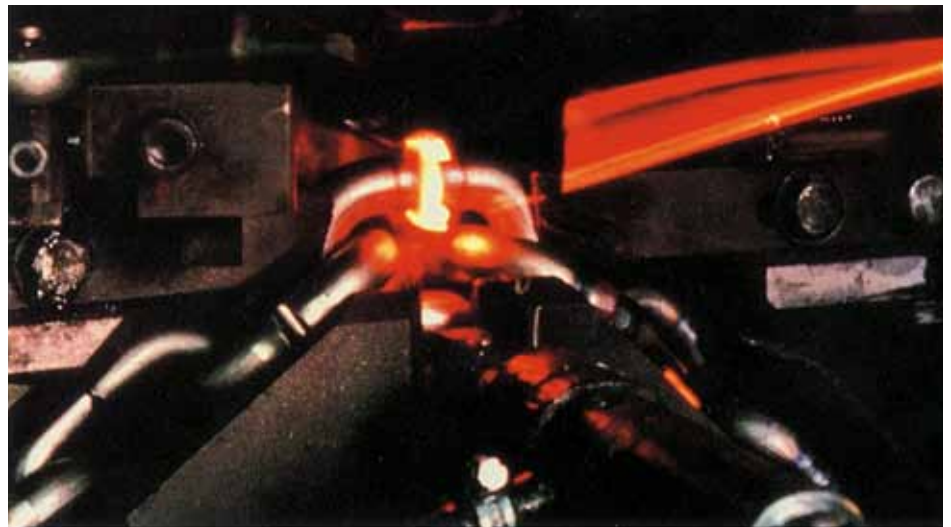

All chain and every single component is proof-loaded to a level that corresponds to 2 1/2 times WLL. Individual inspection before delivery from our factories ensures high and consistent quality.

Chain and components are tested to destruction on a random sample basis from every production batch. **Minimum breaking force = Maximum working load limit x Design Factor.** Full test data is documented. The prescribed elongation for Gunnebo Lifting G80 and G100 Alloy chains is minimum 20%.

Additionally, finished products are subjected to testing to ensure the correct hardness levels. Cyclical loading tests are also carried out to simulate the fatigue effects that would be expected over many years of use.

Chain and components carry identification marks for full traceability back to the steel supplier for raw material analysis.

## Safety *Put to the Test.*

### Index

Alloy Chain & G-Link Couplers . . . . .	2
<b>HOOKS</b>	
Sling Swivel (Eye Type), Cradle Grab (Eye Type) . . . . .	3
Sling (Eye Type), Round Sling (RH) . . . . .	4
Foundry (Eye Type), Clevis Grab (Cradle Type) . . . . .	5
Sling (Clevis Type), Sling (SK Type) . . . . .	6
Shortening (Eye Type), Choker, Shortening Clutch, BL Coupler . . . . .	7
Weld-On Hooks, SK System . . . . .	8
<b>SELF-LOCKING HOOKS</b>	
BK Self-Locking, OBK Self-Locking . . . . .	9
BKL Self-Locking Swivel (Eye Type), Ball Bearing Swivel (Eye Type) . . . . .	10
Shank Type, Web Sling (Eye Type), Hoist Replacement (Clevis Type) . . . . .	11-12
<b>ROLLER BEARING SWIVELS</b>	
Insulated Systems . . . . .	12
<b>ALLOY MASTER LINKS</b>	
Oblong Master Links . . . . .	13
Oblong Master Links w/Sub Assemblies. . . . .	14
Oblong Master Links w/Engineered Flat, & w/Subassemblies & Engineered Flat. . . . .	15
Closed Master Links w/Half Links, Half Link w/Pin/Lockwasher . . . . .	16
Weld-on Lifting Point, Web Round Sling Connector . . . . .	17
SA Shackle, Container Lifting Hooks, Clevis Shackle . . . . .	18
<b>SPARE PARTS</b>	
Spare Parts, I.D. Tag . . . . .	19-21
Chain Sling Type Naming Code . . . . .	22-24
Tips For Chain Sling Assembly. . . . .	25
Sling and BK Hook Warnings and Limitations . . . . .	26-36

### Quality to International Standards

We work closely with our steel suppliers to ensure that the raw material meets our stringent specification.

We also work closely with our world markets and have official approval by the main national and international authorities, including: MOD, NATO, BG, and many others.

All Gunnebo Lifting G80 and G100 Alloy Chains are manufactured and tested to the requirements of ISO 1834 & 3076, 1984, and BS 4942, Parts 1 & 5, 1984. ASTM, A391 and A906, and NACM 90. Gunnebo Lifting G80 and G100 Alloy Chains are randomly subjected to bend testing across the weld to check material ductility and weld integrity. The link bend test is accomplished in the finished condition and meets test requirements of the EN 818 Standard. All components are matched to the Working Load Limits of the relevant chain size.

All G80 and G100 Alloy Chains, and Alloy components meet or exceed the safety standards as prescribed by AISI B30-9 and OSHA 1910-184 for slings.

Our Ramnas factory is approved by Lloyd's (LRQA) for quality assurance to ISO 9001. Our quality management covers all aspects of production from raw material to delivered product. LRQA approval for our system includes design, development, manufacturing, marketing, and distribution of lifting chains and associated components.

Full Test Certification is supplied on request.



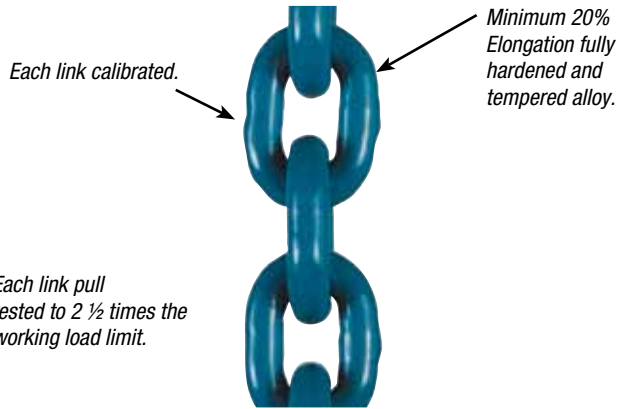

**KLB**

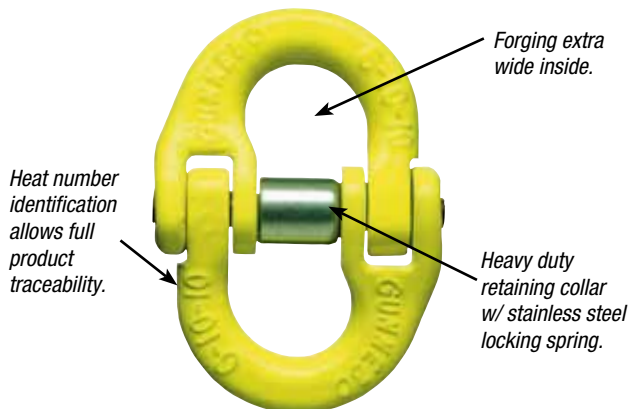

**G-LINK**

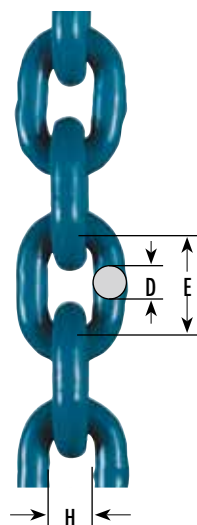

## ALLOY CHAIN GRADE 80 & 100 - KLB

Stock No.	Model	Chain Size In.	Grade	Working Load Limit *(Lbs)	Dimensions (Inches)			Lbs. per ft.	Weight 100 Ft. (Lbs)
					D	E	H		
590405	KLA-7-10	9/32"	100	4,300	0.28	0.83	0.41	0.77	77
590407	KLA-8-10	5/16"	100	5,700	0.32	0.94	0.45	0.97	97
590409	KLA-10-10	3/8"	100	8,800	0.40	1.2	0.57	1.5	151
590411	KLA-13-10	1/2"	100	15,000	0.52	1.5	0.72	2.5	253
590413	KLA-16-10	5/8"	100	22,600	0.65	1.9	0.91	3.9	394
590414	KLA-20-10	3/4"	100	35,300	0.81	2.4	1.1	6.3	632
589899	KLA-22-10	7/8"	100	42,700	0.87	2.6	1.2	7.9	793
589900	KLA-26-10	1"	100	59,700	1.02	3.1	1.5	9.8	981
530795	KLB-32-8	1 1/4"	80	72,300	1.3	3.8	1.7	15.5	1,545

\* Design Factor 4:1 Grade Embossed minimum each foot.

## ALLOY COUPLING LINKS - G

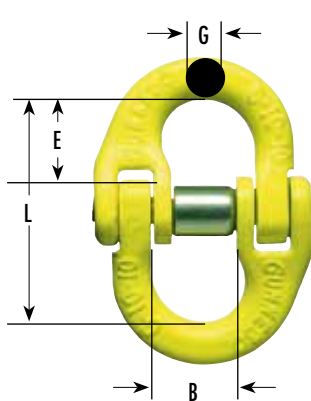

Stock No.	Model	Chain Size In.	Grade	Working Load Limit *(Lbs)	Dimensions (Inches)				Weight Each (Lbs.)
					L	B	G	E	
589672	G-7-10	9/32"	100	4,300	2.2	0.71	0.35	0.87	0.44
589674	G-8-10	5/16"	100	5,700	2.2	0.71	0.35	0.87	0.44
589675	G-10-10	3/8"	100	8,800	2.7	1.0	0.47	1.0	0.66
589676	G-13-10	1/2"	100	15,000	3.5	1.1	0.59	1.3	1.5
589677	G-16-10	5/8"	100	22,600	4.1	1.4	0.75	1.6	2.6
589679	G-20-10	3/4"	100	35,300	4.9	1.7	1.0	1.9	5.7
589680	G-22-10	7/8"	100	42,700	6.0	2.0	1.0	2.3	7.7
589681	G-26-10	1"	100	59,700	6.3	2.3	1.3	2.4	12.6
545109	G-32-8	1 1/4"	80	72,300	7.9	2.8	1.5	3.1	19.0

\* Design Factor 4:1 Proof tested and certified.



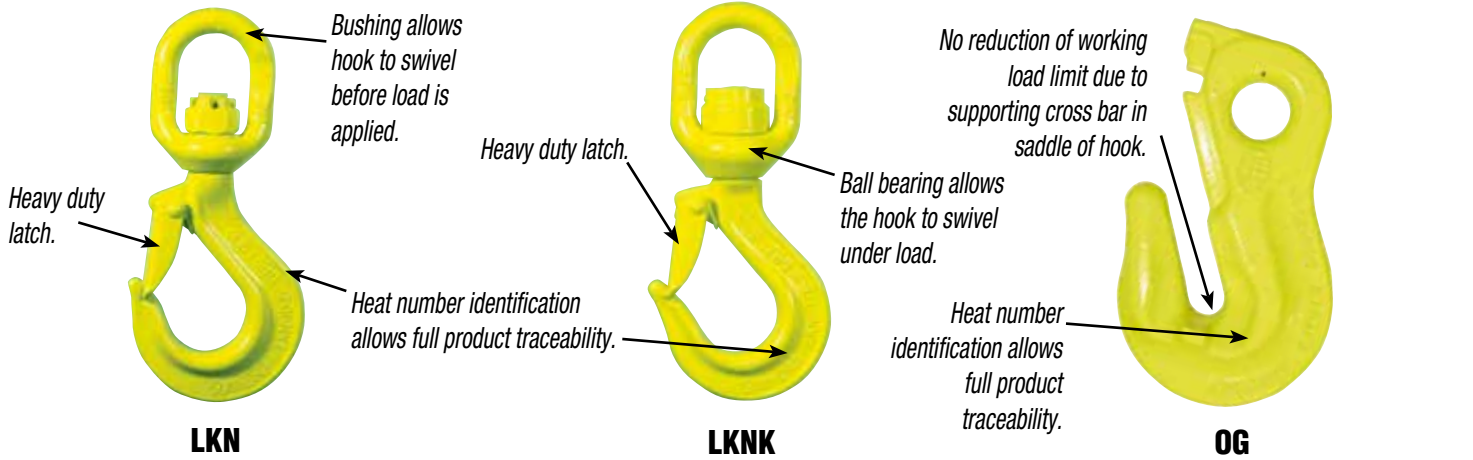

## Alloy Hooks

### SWIVEL SLING HOOKS - LKN WITH LATCH & BRONZE BUSHINGS (EYE TYPE)

Stock No.	Model	Chain Size In.	Grade	Working Load Limit *(Lbs)	Dimensions (Inches)								Weight Each (Lbs.)
					L	B	G	C	H	E	F		
511295	LKN-7/8-8	9/32"	80	3,500	6.1	1.1	0.71	1.1	0.93	1.4	0.47	1.8	
511295	LKN-7/8-8	5/16"	80	4,500	6.1	1.1	0.71	1.1	0.93	1.4	0.47	1.8	
590461	LKN-10-10	3/8"	100	8,800	7.6	1.4	0.9	1.5	1.2	1.7	0.59	3.3	
511297	LKN-13-8	1/2"	80	12,000	9.4	1.6	1.1	1.9	1.4	1.9	0.75	6.8	
511298	LKN-16-8	5/8"	80	18,100	11.6	2.1	1.3	2.4	1.7	2.4	0.87	11.2	

\* Design Factor 4:1 Proof tested and certified.

### SWIVEL SLING HOOKS - LKNK WITH LATCH & BALL BEARINGS (EYE TYPE)

Stock No.	Model	Chain Size In.	Grade	Working Load Limit *(Lbs)	Dimensions (Inches)								Weight Each (Lbs.)
					L	B	G	C	H	E	F		
530020	LKNK-7/8-8	9/32"	80	3,500	6.1	1.1	0.71	1.1	0.93	1.4	0.47	2.0	
530020	LKNK-7/8-8	5/16"	80	4,500	6.1	1.1	0.71	1.1	0.93	1.4	0.47	2.0	
590465	LKNK-10-10	3/8"	100	8,800	7.6	1.4	0.9	1.4	1.2	1.7	0.59	3.5	
530022	LKNK-13-8	1/2"	80	12,000	9.4	1.6	1.1	1.9	1.4	1.9	0.75	6.8	
530023	LKNK-16-8	5/8"	80	18,100	11.6	2.1	1.3	2.3	1.7	2.4	0.87	11.7	

\* Design Factor 4:1 Proof tested and certified.

### EYE GRAB HOOKS - OG \*\* (CRADLE TYPE)

Stock No.	Model	Chain Size In.	Grade	Working Load Limit *(Lbs)	Dimensions (Inches)				Weight Each (Lbs.)
					L	B	E	F	
589605	OG-7/8-8	9/32"	80	3,500	2.6	0.39	0.63	0.39	0.66
589605	OG-7/8-8	5/16"	80	4,500	2.6	0.39	0.63	0.39	0.66
512210	OG-10-8	3/8"	80	7,100	3.3	0.47	0.79	0.47	1.3
512220	OG-13-8	1/2"	80	12,000	4.1	0.59	1.0	0.63	2.6
512230	OG-16-8	5/8"	80	18,100	5.1	0.75	1.2	0.75	5.3
589454	OG-19/20-8	3/4"	80	28,300	6.1	0.89	1.4	0.91	10.1
590449	OG-22-10	7/8"	100	42,700	7.4	1.0	1.8	1.3	19.0
590450	OG-26-10	1"	100	59,700	9.0	1.3	2.2	1.5	30.9

\* Design Factor 4:1 Proof tested and certified.

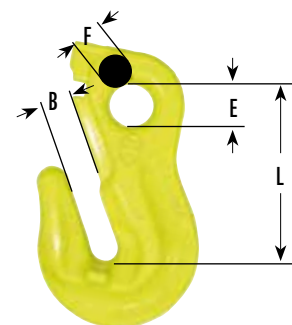
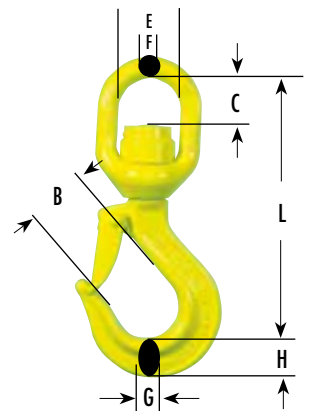
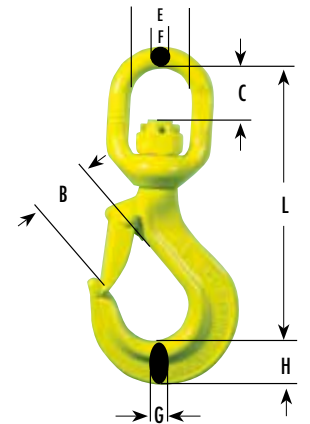

Quickly attaches through the latch to Round or WEB SLING

Forged cover on hook body protects the latch against snagging

Heat number identification allows full product traceability.

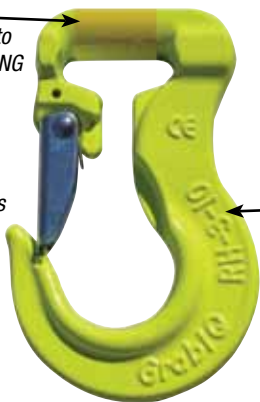

**RH**

Standard heavy duty latch with slotted tip to resist side loading.

Forged cover on the hook body protects the latch against snagging.

Heat number identification allows full product traceability.



**EKN**

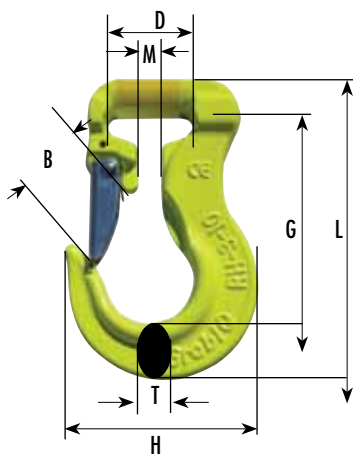

### SLING HOOK - RH

Stock No.	Model	Chain Size In.	Grade	Working Load Limit *(Lbs)	Dimensions (Inches)							Weight Each (Lbs.)
					L	B	D	G	H	M	T	
589588	RH-1-10	1	100	2,200	4.6	0.94	1.4	3.3	2.9	0.31	0.67	0.88
589590	RH-2-10	2	100	4,400	5.4	1.1	1.6	3.8	3.4	0.39	0.67	1.5
589591	RH-3-10	3	100	6,600	6.6	1.3	1.9	4.6	4.3	0.47	0.94	3.1
589592	RH-5-10	5	100	11,000	8.7	1.7	2.9	6.1	5.2	0.65	1.06	7.1

\* Design Factor 5:1 Proof tested and certified.

### SLING HOOK - EKN WITH RECESSED LATCH (EYE TYPE)

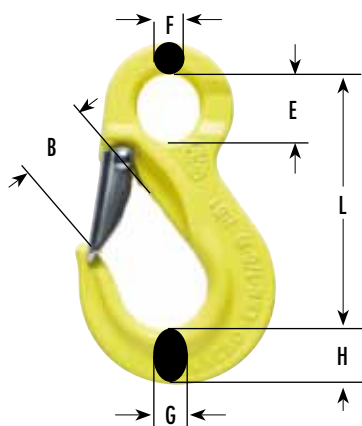

Stock No.	Model	Chain Size In.	Grade	Working Load Limit *(Lbs)	Dimensions (Inches)						Weight Each (Lbs.)
					L	B	G	H	E	F	
590277	EKN-6-10	7/32"	100	2,700	3.7	0.94	0.67	0.79	0.87	0.39	0.66
590279	EKN-7/8-10	9/32"	100	4,300	4.3	1.1	0.67	0.91	1.1	0.51	1.1
590279	EKN-7/8-10	5/16"	100	5,700	4.3	1.1	0.67	0.91	1.1	0.51	1.1
590281	EKN-10-10	3/8"	100	8,800	5.3	1.5	0.9	1.2	1.3	0.59	2.2
590282	EKN-13-10	1/2"	100	15,000	6.5	1.7	1.1	1.5	1.7	0.75	4.4
590283	EKN-16-10	5/8"	100	22,600	8.0	2.0	1.4	1.8	2.2	0.94	8.2
590284	EKN-20-10	3/4"	100	35,300	9.0	2.4	1.7	2.4	2.4	1.0	13.9
590285	EKN-22-10	7/8"	100	42,700	10.5	2.9	1.7	2.6	2.5	1.2	19.2
590286	EKN-26-10	1"	100	59,700	11.9	3.2	2.0	3.0	2.6	1.3	29.1
590287	EKN-32-8	1 1/4"	80	72,300	13.1	3.7	2.4	3.1	3.0	1.5	39.5

\* Design Factor 4:1 Proof tested and certified.

EKN hook replaces OKN sling hook

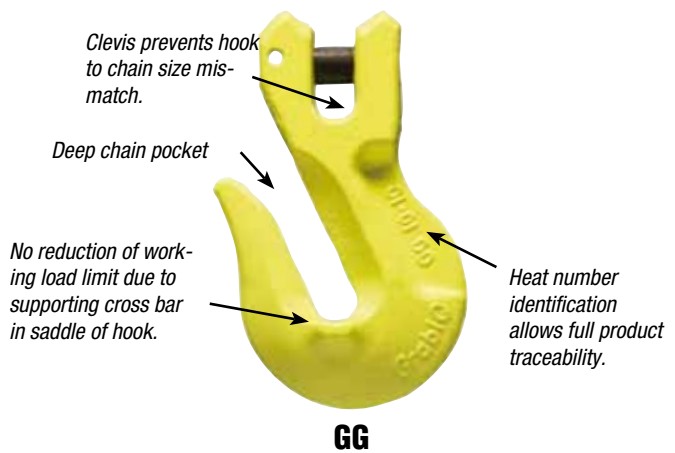

## FOUNDRY HOOKS - OKE (EYE TYPE)

Stock No.	Model	Chain Size In.	Grade	Working Load Limit *(Lbs)	Dimensions (Inches)		Dimensions (Inches)		G	H	Weight Each (Lbs.)
					L	B	E	F			
589725	OKE-7/8-10	9/32"	100	4,300	4.8	2.5	1.1	0.45	0.79	1.0	1.5
589725	OKE-7/8-10	5/16"	100	5,700	4.8	2.5	1.1	0.45	0.79	1.0	1.5
589727	OKE-10-10	3/8"	100	8,800	5.9	3.0	1.3	0.59	1.0	1.1	2.9
589728	OKE-13-10	1/2"	100	15,000	7.2	3.5	1.7	0.75	1.3	1.5	6.2
589729	OKE-16-10	5/8"	100	22,600	8.5	4.0	2.2	0.91	1.6	1.8	10.8
589730	OKE-20-10	3/4"	10	35,300	9.7	4.5	2.4	1.1	1.8	2.4	15.9
589732	OKE-22-10	7/8"	100	42,700	10.8	4.7	2.5	1.2	2.4	2.8	24.9
589733	OKE-26-10	1"	100	59,700	11.8	4.4	2.8	1.38	2.5	3.0	35.3
545467	OKE-32-8	1 1/4"	80	72,300	15.1	5.7	3.5	1.7	3.0	3.7	67.0

\* Design Factor 4:1 Proof tested and certified.

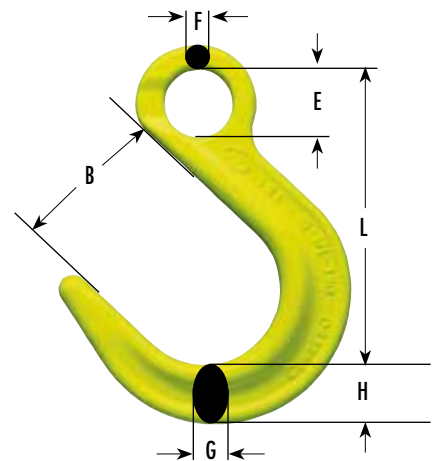

## CLEVIS GRAB HOOKS - GG (CRADLE TYPE)

Stock No.	Model	Chain Size In.	Grade	Working Load Limit *(Lbs)	Dimensions (Inches)		Weight Each (Lbs.)
					L	B	
589685	GG-7-10	9/32"	100	4,300	2.2	0.39	0.66
589687	GG-8-10	5/16"	100	5,700	2.2	0.41	0.88
589688	GG-10-10	3/8"	100	8,800	3.3	0.47	2.0
589689	GG-13-10	1/2"	100	15,000	3.8	0.63	4.0
589690	GG-16-10	5/8"	100	22,600	4.9	0.79	6.8
589692	GG-20-10	3/4"	100	35,300	5.8	1.0	15.4

\* Design Factor 4:1 Proof tested and certified.

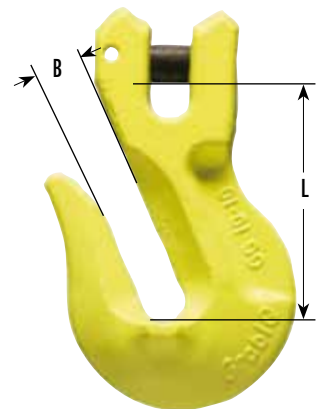

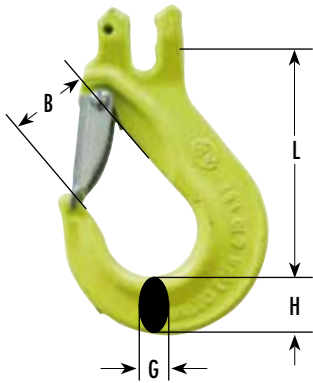
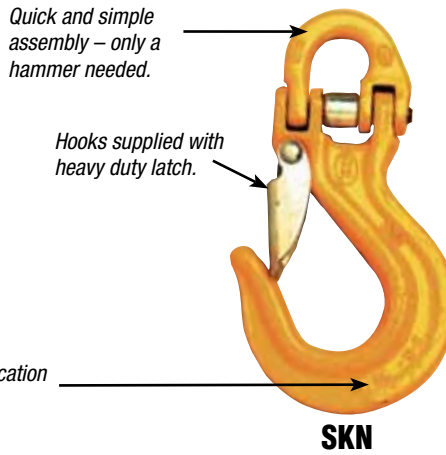
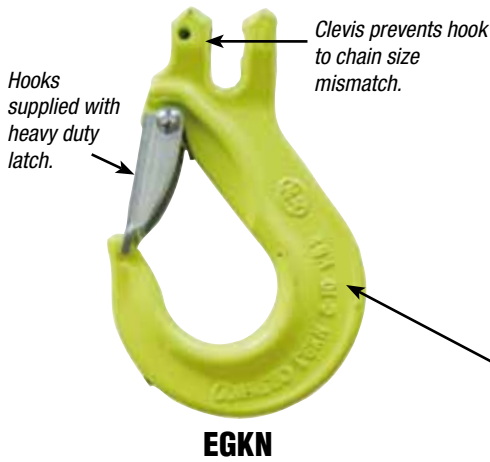

## SLING HOOKS - EGKN WITH LATCH (CLEVIS TYPE)

Stock No.	Model	Chain Size In.	Grade	Working Load Limit *(Lbs)	L	Dimensions (Inches)			Weight Each (Lbs.)
						B	G	H	
589711	EGKN-7-10	9/32"	100	4,300	3.7	1.1	0.67	0.87	1.1
589713	EGKN-8-10	5/16"	100	5,700	3.7	1.1	0.67	0.87	1.1
589714	EGKN-10-10	3/8"	100	8,800	4.8	1.4	0.91	1.2	2.2
589715	EGKN-13-10	1/2"	100	15,000	5.7	1.7	1.1	1.5	5.1
589716	EGKN-16-10	5/8"	100	22,600	6.7	2.0	1.4	1.8	8.4
589718	EGKN-20-10	3/4"	100	35,300	8.2	2.4	1.7	2.4	16.8

\* Design Factor 4:1 Proof tested and certified.  
EGKN hook replaces GKN sling hook.

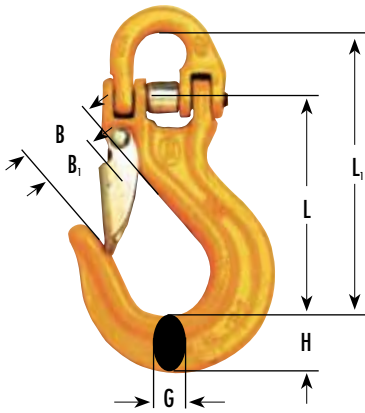

## SLING HOOKS - SKN WITH HALF LINKS & LATCH

Stock No.	Model	Chain Size In.	Grade	Working Load Limit *(Lbs)	L	L1	Dimensions (Inches)			Weight Each (Lbs.)	
							B	B1	G		
545621	SKN-7/8-8 w/ SKT	9/32"	80	3,500	3.5	4.6	1.3	1.1	0.71	0.83	1.10
545621	SKN-7/8-8 w/ SKT	5/16"	80	4,500	3.5	4.6	1.3	1.1	0.71	0.83	1.10
545622	SKN-10-8 w/ SKT	3/8"	80	7,100	4.5	5.9	1.6	1.3	0.91	1.1	2.4
590340	ESKN-13-8 w/ SKT	1/2"	80	12,000	5.7	7.4	2.0	1.7	1.1	1.4	5.1
589609	ESKN-16-8 w/ SKT	5/8"	80	18,100	7.1	9.2	2.4	2.1	1.3	1.7	9.0
589610	ESKN-18/20-8 w/ SKT	3/4"	80	28,300	7.8	10.2	2.6	2.3	1.6	2.0	13.4

\* Design Factor 4:1 Proof tested and certified.



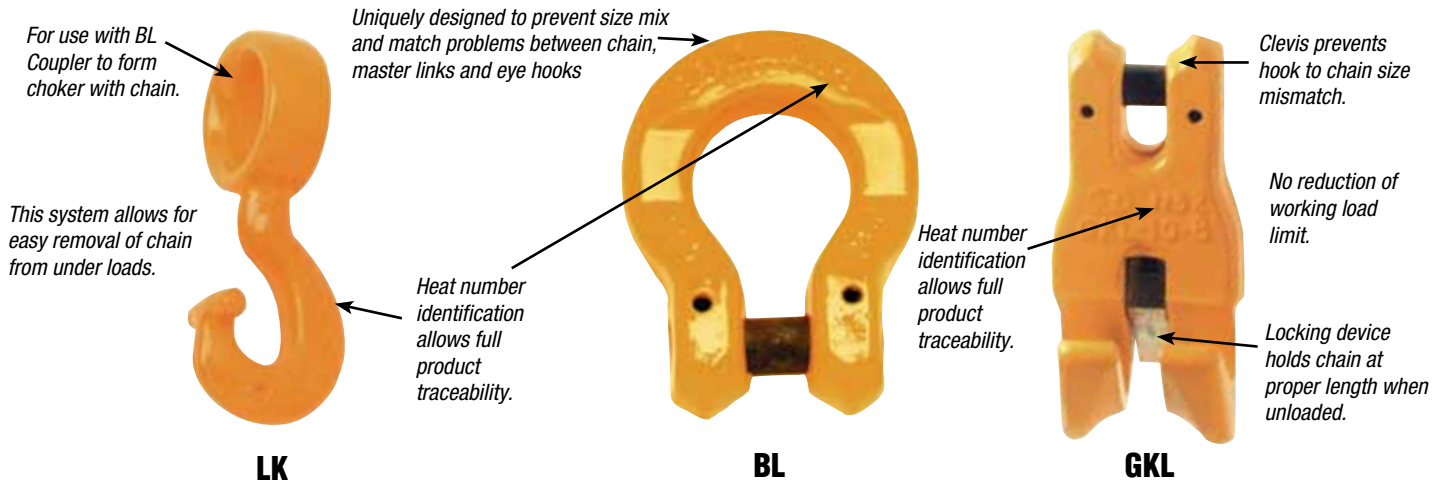

## CHOKER HOOKS - LK

Stock No.	Model	Chain Size In.	Grade	Working Load Limit *(Lbs)	Dimensions (Inches)			Weight Each (Lbs.)
					L	B	E	
545991	LK-7/8-8	9/32"	80	3,500	3.8	0.75	1.3	0.7
545991	LK-7/8-8	5/16"	80	4,500	3.8	0.75	1.3	0.7
545992	LK-10-8	3/8"	80	7,100	4.7	0.83	1.7	1.8
545993	LK-13-8	1/2"	80	12,000	5.9	1.0	2.0	4.0

\* Design Factor 4:1 Proof tested and certified.

Used with BL coupler (below) to form choker with chain.

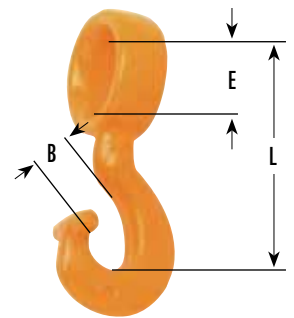
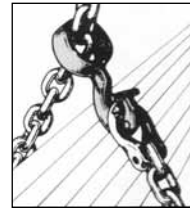

## COUPLER - BL

Stock No.	Model	Chain Size In.	Grade	Working Load Limit *(Lbs)	Dimensions (Inches)				Weight Each (Lbs.)
					L	B	G	H	
545341	BL-7/8-8	9/32"	80	3,500	1.4	1.0	0.43	0.71	0.44
545341	BL-7/8-8	5/16"	80	4,500	1.4	1.0	0.43	0.71	0.44
545342	BL-10-8	3/8"	80	7,100	1.8	1.3	0.55	0.87	0.88
545343	BL-13-8	1/2"	80	12,000	2.2	1.6	0.67	1.1	2.2

\* Design Factor 4:1 Proof tested and certified.

Fits:  
Safety Hooks  
OF & OTF Master Links  
Eye Hooks  
MF & MT Master Links

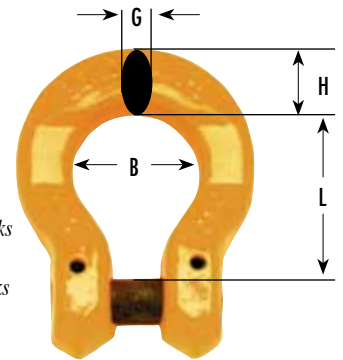

## SHORTENING CLUTCH - GKL (CLEVIS TYPE) (LOCKABLE)

Stock No.	Model	Chain Size In.	Grade	Working Load Limit *(Lbs)	Dimensions (Inches)								Weight Each (Lbs.)
					A	B	C	D	K	L	R	T	
513131	GKL-7-8	9/32"	80	3,500	3.7	1.7	1.7	0.79	0.0	2.6	0.0	0.0	1.1
513132	GKL-8-8	5/16"	80	4,500	3.7	1.7	1.7	0.79	0.0	2.6	0.0	0.0	1.1
513133	GKL-10-8	3/8"	80	7,100	4.7	2.2	2.3	1.0	0.0	3.3	0.0	0.0	2.2
513134	GKL-13-8	1/2"	80	12,000	5.9	2.6	2.9	1.3	0.0	4.1	0.0	0.0	5.3
513135	GKL-16-8	5/8"	80	18,100	7.0	3.1	3.5	1.6	0.0	4.8	0.0	0.0	7.5

\* Design Factor 4:1 Proof tested and certified.

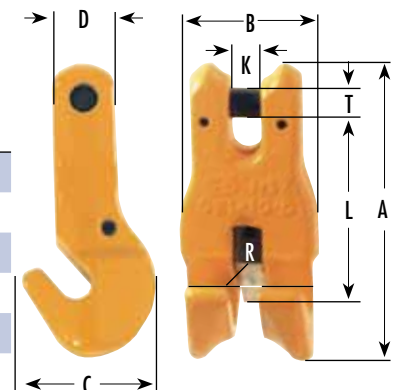



## UKN

## Alloy Specialty Products

### ALLOY WELD-ON HOOKS - UKN

Stock No.	Model	Chain Size In.	Grade	Working Load Limit *(Lbs)	Dimensions (Inches)								Weight Each (Lbs.)
					B	C	G	H	K	L	S	A	
545818	UKN-0.75	0.75	N/A	1650	0.79	2.2	0.51	0.79	0.75	3.2	0.20	0.12	0.66
545817	UKN-1	1	N/A	2200	0.79	2.8	0.67	1.0	1.0	3.7	0.24	0.16	1.3
589357	UKN-2	2	N/A	4400	1.0	3.4	0.79	1.2	1.2	4.5	0.31	0.20	2.2
545823	UKN-3	3	N/A	6600	1.2	4.1	0.91	1.3	1.4	5.2	0.39	0.24	2.9
545816	UKN-4	4	N/A	8800	1.1	4.5	1.1	1.5	1.7	5.5	0.43	0.28	4.2
545821	UKN-5	5	N/A	11000	1.3	5.2	1.2	1.9	1.8	6.5	0.47	0.31	6.4
545815	UKN-8	8	N/A	17600	1.3	5.2	1.6	2.0	2.0	6.8	0.51	0.35	7.7
545822	UKN-10	10	N/A	22000	1.9	6.7	1.7	2.3	2.2	8.7	0.55	0.35	14.1
589587	UKN-15	15	N/A	33000	2.1	7.4	2.0	2.6	2.4	9.4	0.59	0.47	19.4

\* Design factor 5:1 Proof tested and certified.

\*\*Welding plate on UKN-0.75, UKN-2, and UKN-1 is slightly curved.

For welding use electrode AWS A 5.1 E 7018

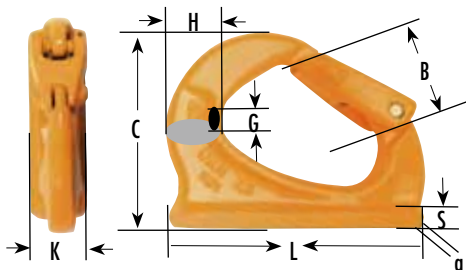

## The SK System

A range of specialized Grade 80 Alloy Steel components for easy assembly to chain, steel wire rope, webbing and round slings. Be creative (mix and match); this system is designed to solve many of your below the hook lifting problems.

The SK System provides:

- Universal coupling of components to chain, wire and synthetic slings.
- Quick and easy assembly - only a hammer needed.
- Foolproof assembly - standardized dimensions within each size range effectively eliminates the wrong assembly of components with different working load limits.

- Heavy hoisting with strong yet lightweight equipment - all components are manufactured from alloy steel for use with Grade 80 Chain.
- Individual components are proof-load tested to 62% of ultimate.
- Official approval by the main national and international authorities, including MOD, NATO, Norske Veritas, DIN and many others.

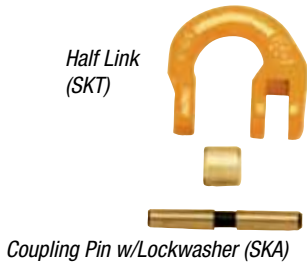

Open Master Link (SKO)



Closed Master Link (SKG)



Sling Hook w/Latch (SKN)



Roller Bearing Swivel



Insulated (SKLI)



Web/Roundsling Coupler (SKR)



SEE WARNINGS AND USE LIMITATIONS ON PAGES 26-36

All three hooks are equipped with Stainless Steel Triggers.

Latch is protected and will act as a gauge to signal an unsafe bent hook or latch.

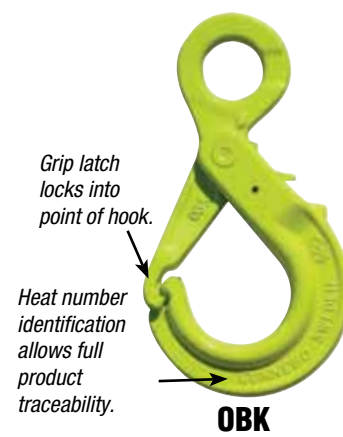
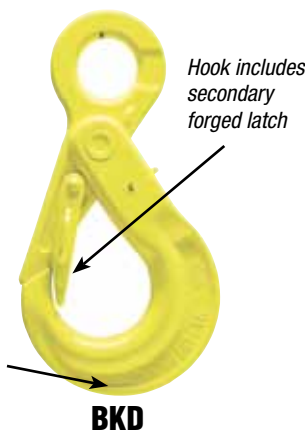
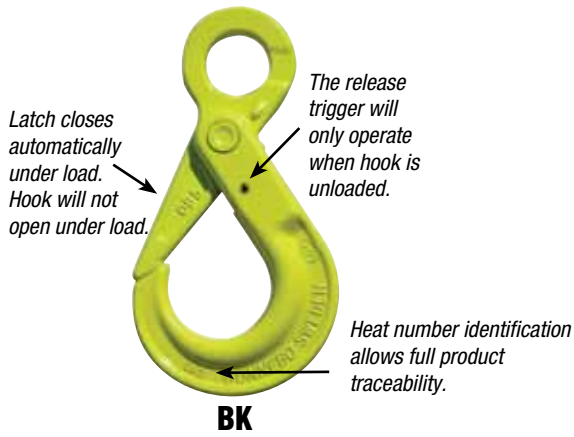

## Alloy BK Self-Locking Hooks

### SELF-LOCKING HOOKS - BK (EYE TYPE)

Stock No.	Model	Chain Size In.	Grade	Working Load Limit *(Lbs)	Dimensions (Inches)						Weight Each (Lbs.)
					L	B	E	F	G	H	
590064	BK-6-10	7/32"	100	2,700	4.3	1.1	0.87	0.39	0.59	0.83	1.1
590066	BK-7/8-10	9/32"	100	4,300	5.4	1.5	1.1	0.43	0.67	1.0	2.0
590066	BK-7/8-10	5/16"	100	5,700	5.4	1.5	1.1	0.43	0.67	1.0	2.0
590068	BK-10-10	3/8"	100	8,800	6.6	1.7	1.3	0.51	0.83	1.2	3.3
590069	BK-13-10	1/2"	100	15,000	8.1	2.1	1.7	0.63	1.2	1.5	6.2
590070	BK-16-10	5/8"	100	22,600	10.0	2.4	2.2	0.79	1.5	1.9	12.3
590071	BK-18/20-10	3/4"	100	35,300	11.4	2.7	2.4	0.87	1.7	2.5	18.3
590073	BK-22-10	7/8"	100	42,700	12.6	3.1	2.8	0.9	2.0	2.4	24.9
590074	BK-26-10	1"	100	59,700	13.5	3.9	3.1	1.0	2.1	2.7	36.4
590479	BK-26-10 OFFS**	1"	100	59,700	13.5	3.9	3.1	1.0	2.1	2.7	36.4
590477	BK-32-8	1 1/4"	80	72,300	15.7	4.7	3.5	1.2	2.4	3.4	52.5

\*\* DNV 2.7-1 Type Approval

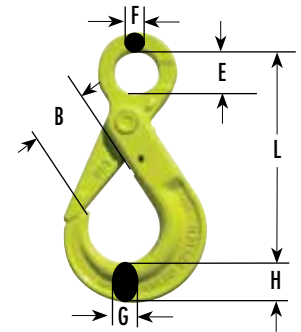

### BKD - DOUBLE LATCH SELF-LOCKING HOOK

Stock No.	Model	Chain Size In.	Grade	Working Load Limit *(Lbs)	Dimensions (Inches)						Weight Each (Lbs.)
					L	B	E	F	G	H	
590420	BKD-13-10	1/2"	100	15,000	8.1	1.7	1.7	0.63	1.2	1.5	7.1
590423	BKD-16-10	5/8"	100	22,600	10.0	1.9	2.2	0.79	1.5	1.9	12.8
590424	BKD-18/20-10	3/4"	100	35,300	11.4	2.2	2.4	0.87	1.7	2.5	19.4

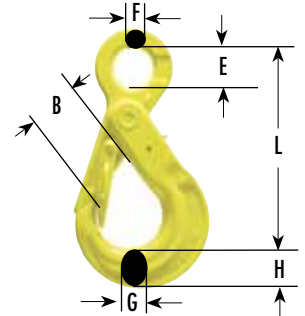

### SELF-LOCKING HOOKS - OBK WITH GRIP LATCH (EYE TYPE)

Stock No.	Model	Chain Size In.	Grade	Working Load Limit *(Lbs)	Dimensions (Inches)						Weight Each (Lbs.)
					L	B	E	F	G	H	
590213	OBK-6-10	7/32"	100	2,700	4.1	1.0	0.87	0.35	0.55	0.67	0.88
590215	OBK-7/8-10	9/32"	100	4,300	5.5	1.5	1.1	0.39	0.79	0.87	1.8
590215	OBK-7/8-10	5/16"	100	5,700	5.5	1.5	1.1	0.39	0.79	0.87	1.8
590217	OBK-10-10	3/8"	100	8,800	6.7	1.9	1.3	0.51	0.87	1.1	2.9
590218	OBK-13-10	1/2"	100	15,000	8.1	2.1	1.7	0.59	1.1	1.4	5.3
590219	OBK-16-10	5/8"	100	22,600	9.8	2.7	2.2	0.75	1.1	1.7	9.3
590220	OBK-18/20-10	3/4"	100	35,300	11.5	2.9	2.4	1.02	1.7	2.2	17.9
511006	OBK-22-8	7/8"	80	34,200	13.2	3.4	2.8	0.94	1.6	2.2	22.0

\* Design Factor 4:1 Proof tested and certified.

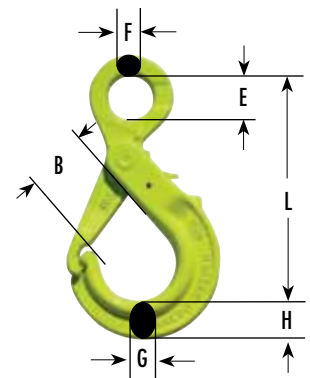

All three hooks are equipped with stainless steel triggers.

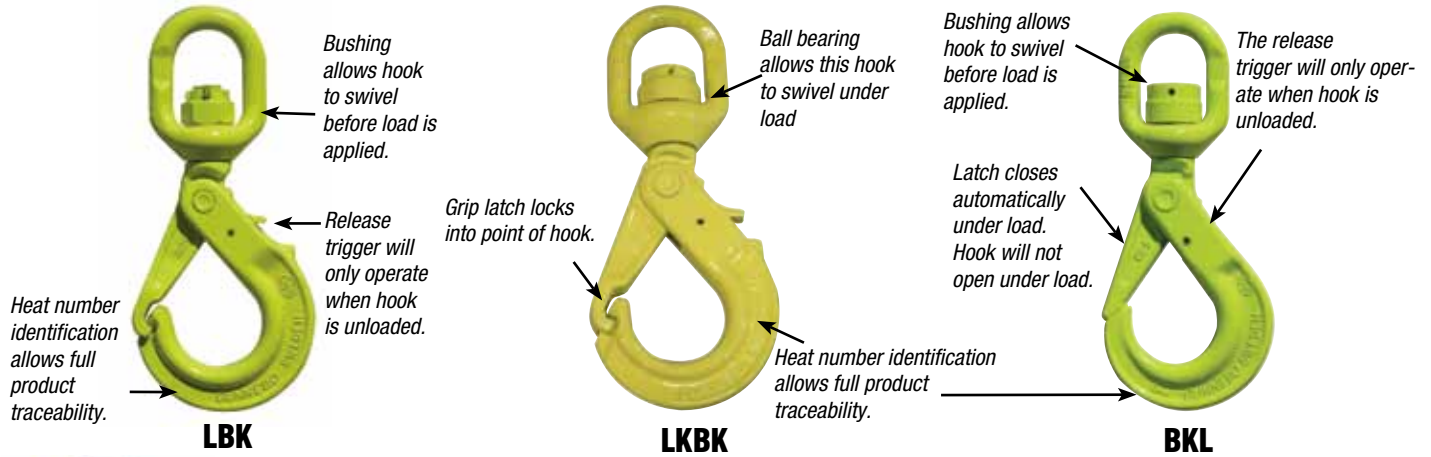

## SELF-LOCKING HOOKS - LBK SWIVEL EYE GRIP LATCH (WITH BRONZE BUSHING)

Stock No.	Model	Chain Size In.	Grade	Working Load Limit *(Lbs)	Dimensions (Inches)								Weight Each (Lbs.)
					L	B	C	E	F	G	H		
589751	LBK-7/8-10	9/32"	100	4,300	6.9	1.5	1.1	1.5	0.47	0.79	0.87	1.8	
589751	LBK-7/8-10	5/16"	100	5,700	6.9	1.5	1.1	1.5	0.47	0.79	0.87	1.8	
589753	LBK-10-10	3/8"	100	8,800	8.4	1.9	1.4	1.7	0.59	0.87	1.1	4.0	
589754	LBK-13-10	1/2"	100	15,000	9.3	2.1	1.9	1.9	0.75	1.1	1.4	8.4	
589755	LBK-16-10	5/8"	100	22,600	12.8	2.7	2.6	2.4	0.91	1.1	1.7	13.2	

\* Design Factor 4:1 Proof tested and certified.  
 Note: Hook may not be swiveled when under load.

## SELF-LOCKING HOOKS - LKBK SWIVEL EYE GRIP LATCH (WITH BALL BEARINGS)

Stock No.	Model	Chain Size In.	Grade	Working Load Limit *(Lbs)	Dimensions (Inches)								Weight Each (Lbs.)
					L	B	C	E	F	G	H		
589963	LKBK-7/8-10	9/32"	100	4,300	6.9	1.5	1.1	1.5	0.47	0.79	0.87	1.8	
589963	LKBK-7/8-10	5/16"	100	5,700	6.9	1.5	1.1	1.5	0.47	0.79	0.87	1.8	
589965	LKBK-10-10	3/8"	100	8,800	8.4	1.9	1.4	1.7	0.59	0.87	1.1	4.0	
589966	LKBK-13-10	1/2"	100	15,000	9.3	2.1	1.9	1.9	0.75	1.1	1.4	8.4	
589967	LKBK-16-10	5/8"	100	22,600	12.6	2.7	2.4	2.4	0.91	1.1	1.7	13.2	

\* Design Factor 4:1 Proof tested and certified.

## SELF-LOCKING HOOKS - BKL WITH BRONZE BUSHINGS (SWIVEL EYE TYPE)

Stock No.	Model	Chain Size In.	Grade	Working Load Limit *(Lbs)	Dimensions (Inches)								Weight Each (Lbs.)
					L	B	C	E	F	G	H		
590102	BKL-6-10	7/32"	100	2,700	5.9	1.1	0.9	1.3	0.43	0.59	0.83	1.5	
590104	BKL-7/8-10	9/32"	100	4,300	7.2	1.5	1.1	1.5	0.47	0.67	1.0	2.6	
590104	BKL-7/8-10	5/16"	100	5,700	7.2	1.5	1.1	1.5	0.47	0.67	1.0	2.6	
590106	BKL-10-10	3/8"	100	8,800	8.6	1.7	1.4	1.7	0.59	0.83	1.2	4.4	
590107	BKL-13-10	1/2"	100	15,000	11.0	2.1	1.9	1.9	0.75	1.2	1.5	8.4	
590108	BKL-16-10	5/8"	100	22,600	13.5	2.4	2.6	2.4	0.87	1.5	1.9	15.6	
590109	BKL-18/20-10	3/4"	100	35,300	14.4	2.7	2.8	2.9	1.0	1.7	2.5	24.5	

\* Design Factor 4:1 Proof tested and certified.

Note: Hook may not be swiveled when under load.

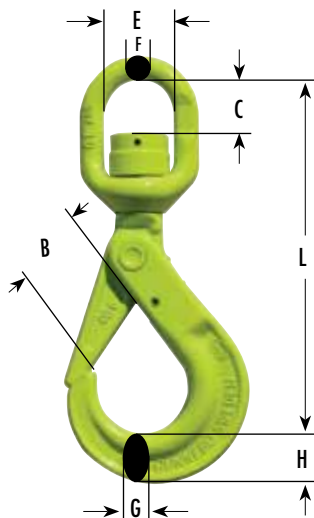
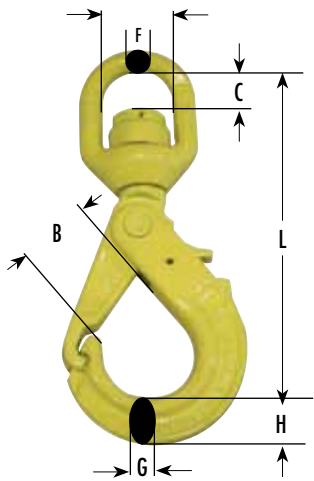
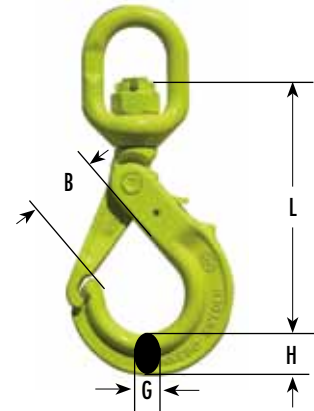



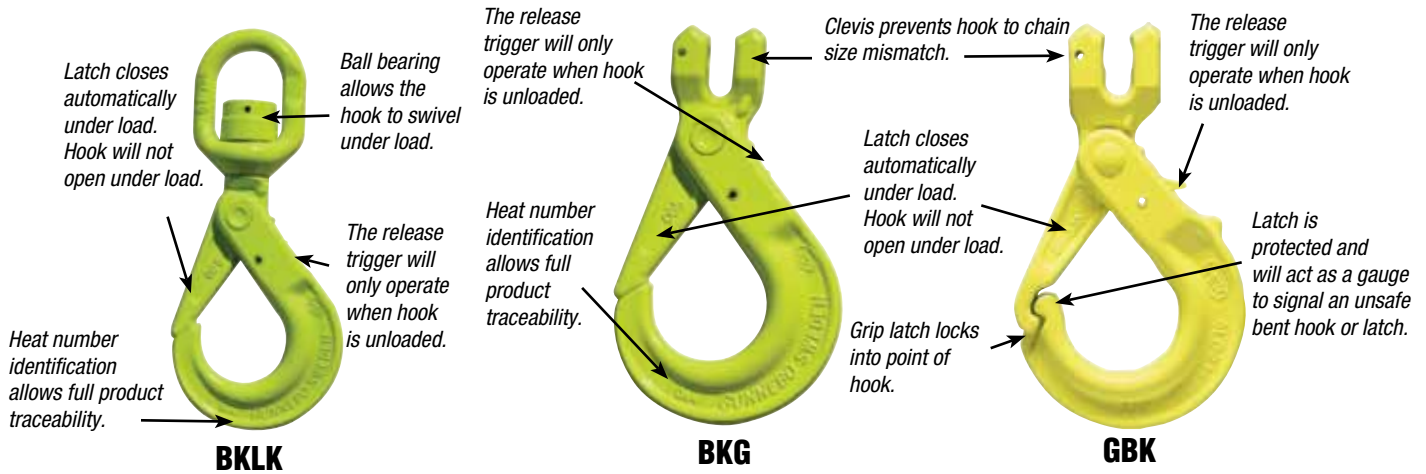

## SELF-LOCKING HOOKS - BKLK WITH BALL BEARINGS (SWIVEL EYE TYPE)

Stock No.	Model	Chain Size In.	Grade	Working Load Limit *(Lbs)	Dimensions (Inches)								Weight Each (Lbs.)
					L	B	C	E	F	G	H		
590121	BKLK-6-10	7/32"	100	2,700	5.9	1.1	0.94	1.3	0.43	0.59	0.83	1.5	
590123	BKLK-7/8-10	9/32"	100	4,300	7.2	1.5	1.1	1.5	0.47	0.67	1.0	2.6	
590123	BKLK-7/8-10	5/16"	100	5,700	7.2	1.5	1.1	1.5	0.47	0.67	1.0	2.6	
590125	BKLK-10-10	3/8"	100	8,800	8.6	1.7	1.4	1.7	0.59	0.83	1.2	4.2	
590126	BKLK-13-10	1/2"	100	15,000	11.1	2.1	1.8	1.9	0.75	1.2	1.5	8.4	
590127	BKLK-16-10	5/8"	100	22,600	13.3	2.5	2.5	2.4	0.87	1.5	1.9	15.9	
590128	BKLK-18/20-10	3/4"	100	35,300	14.4	2.7	2.3	2.9	1.0	1.7	2.5	24.9	
590129	BKLK-22-10	7/8"	100	42,700	17.2	3.1	3.1	3.1	1.4	2.0	2.4	37.0	
590130	BKLK-26-10 OFFS **	1"	100	59,700	19.1	3.9	4.3	4.0	1.8	2.1	2.7	57.3	
590480	BKLK-32-8 OFFS **	1 1/4"	80	72,300	21.0	4.7	4.3	4.0	1.8	2.4	3.4	71.2	

\*\* DNV 2.7-1 Type Approval

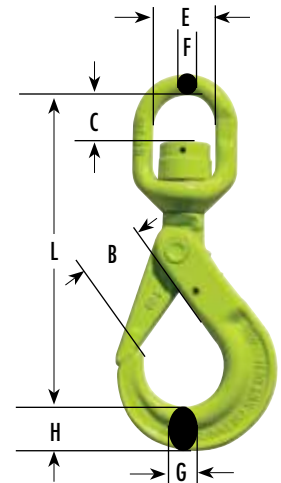

## SELF-LOCKING HOOKS - BKG (CLEVIS TYPE)

Stock No.	Model	Chain Size In.	Grade	Working Load Limit *(Lbs)	L	Dimensions (Inches)			Weight Each (Lbs.)
						B	G	H	
590084	BKG-7-10	9/32"	100	4,300	4.7	1.5	0.67	0.98	1.8
590086	BKG-8-10	5/16"	100	5,700	4.8	1.5	0.67	1.0	2.0
590087	BKG-10-10	3/8"	100	8,800	5.6	1.8	0.83	1.2	3.3
590088	BKG-13-10	1/2"	100	15,000	7.1	2.1	1.2	1.5	6.6
590089	BKG-16-10	5/8"	100	22,600	8.9	2.4	1.5	1.9	12.6
590091	BKG-20-10	3/4"	100	35,300	9.4	2.9	1.7	2.5	21.2

\* Design Factor 4:1 Proof tested and certified.

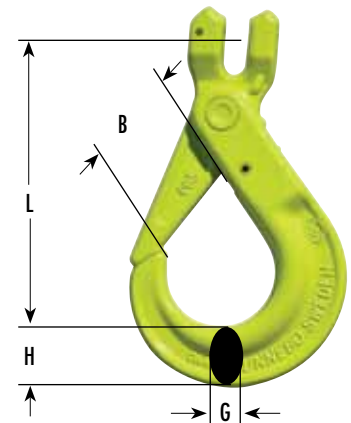

## SELF-LOCKING HOOKS - GBK WITH GRIP LATCH (CLEVIS TYPE)

Stock No.	Model	Chain Size In.	Grade	Working Load Limit *(Lbs)	L	Dimensions (Inches)			Weight Each (Lbs.)
						B	G	H	
589737	GBK-7-10	9/32"	100	4,300	4.7	1.5	0.79	0.87	1.8
589739	GBK-8-10	5/16"	100	5,700	4.7	1.5	0.79	0.87	1.8
589740	GBK-10-10	3/8"	100	8,800	5.9	1.9	0.83	1.2	3.1
589741	GBK-13-10	1/2"	100	15,000	6.8	2.1	1.2	1.5	6.0
589742	GBK-16-10	5/8"	100	22,600	8.1	2.4	1.5	1.9	9.7

\* Design Factor 4:1 Proof tested and certified.

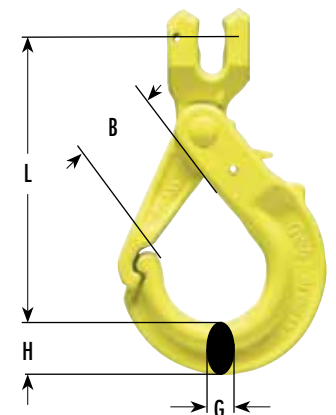



Replacement for single chain hoists.

Equipped with Stainless Steel spring.

Heat number identification allows full product traceability.

Hook will not open under load.



**BKH**

Ball bearing allows the hook to swivel under load.

The release trigger will only operate when hook is unloaded.

Complete system - No assembly required.

Each swivel comes with lubrication and maintenance instructions.



**SKLI**

Insulated for 1000 Volts DC.

Fully rotational at maximum load

Submersible

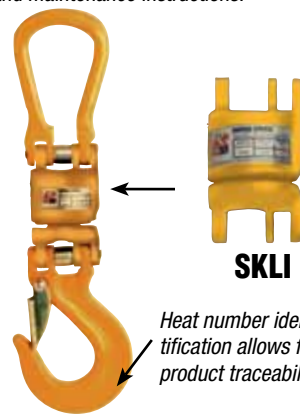

**SKLI**

Heat number identification allows full product traceability.

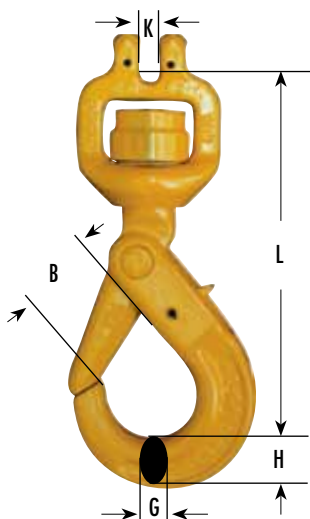

## SELF-LOCKING HOOKS - BKH WITH BALL BEARINGS (CLEVIS SWIVEL TYPE) (SINGLE CHAIN HOIST REPLACEMENT HOOKS)

Stock No.	Model	Chain Size In.	Grade	Working Load Limit *(Lbs)	Dimensions (Inches)					Weight Each (Lbs.)
					L	B	K	G	H	
511400	BKH-6-8	7/32"	80	2,100	5.7	1.1	0.27	0.59	0.83	1.5
511391	BKH-7/8-8	9/32"	80	3,500	7.1	1.5	0.35	0.67	0.91	2.6
511391	BKH-7/8-8	5/16"	80	4,500	7.1	1.5	0.35	0.67	0.91	2.6

\* Design Factor 4:1 Proof tested and certified.

## Alloy Roller Bearing Swivel Systems

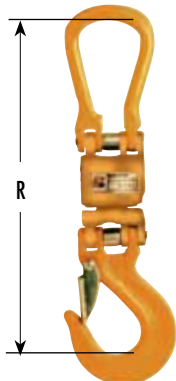

Systems contain (one each per size): "SKO" Master Link  
"SKLI" Ball Bearing Swivel  
"SKN" Sling Hook with Latch

## INSULATED - SKLI INSULATION CAPACITY 1000 VOLTS DC

Stock No.	Model	Chain Size In.	Grade	Working Load Limit *(Lbs)	Dimensions (Inches)		Weight Each (Lbs.)
					L	D	
589327	SKLI-7/8-8	9/32"	80	3,500	3.0	1.9	1.5
589327	SKLI-7/8-8		80	4,500	3.0	1.9	1.5
589328	SKLI-10-8	3/8"	80	7,100	3.8	2.3	3.1
589329	SKLI-13-8	1/2"	80	12,000	4.7	3.0	6.4
589330	SKLI-16-8	5/8"	80	18,100	5.4	3.5	10.8
589331	SKLI-18/20-8	3/4"	80	28,300	6.3	4.1	15.9

\* Design Factor 4:1 Proof tested and certified.

## INSULATED INSULATION CAPACITY 1000 VOLTS DC

Stock No.	Chain Size In.	Grade	Working Load Limit *(Lbs)	Weight Each *(Lbs)	Reach (Inches)
589350	9/32	80	3,500	3.2	10.2
589350	5/16	80	4,500	3.2	10.2
589351	3/8	80	7,100	6.3	13.0
589352	1/2	80	12,000	12.6	15.7
589353	5/8	80	18,100	21.4	18.6
589354	3/4	80	28,300	32.8	21.3

\* Design Factor 4:1 Proof tested and certified.

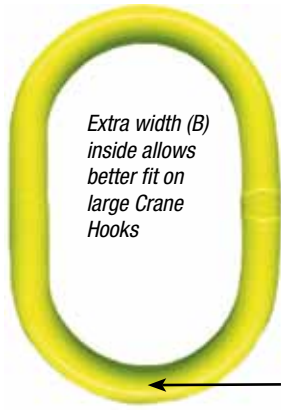

**M**

## Alloy Master Links

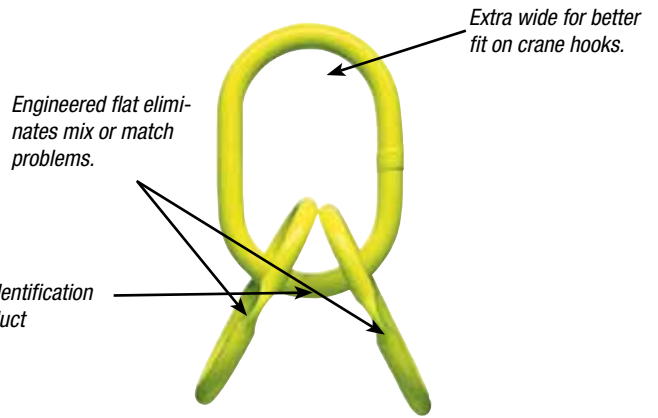

**MT**

### OBLONG MASTER LINKS, GRADE 100 - TYPES M & MT DESIGN FACTOR 5: FOR USE WITH WIRE ROPE

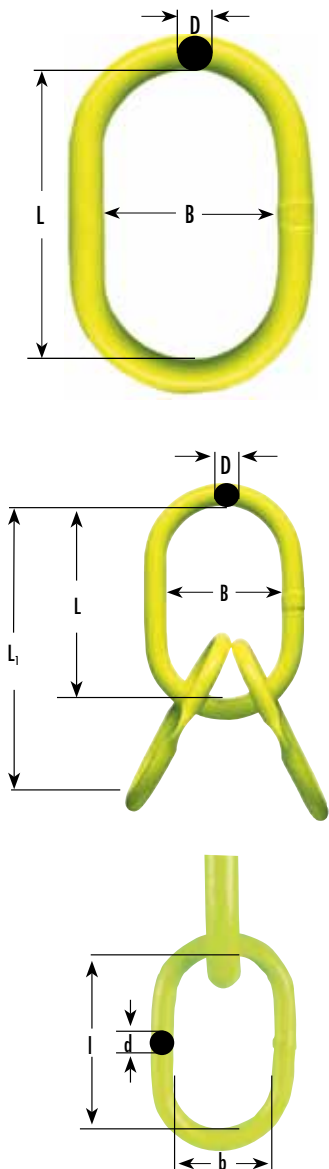

Stock No.	Model	Chain Size In.	Grade	Working Load Limit *(Lbs)	Dimensions (Inches)				Weight Each (Lbs.)			
					L	B	D	L1		l	b	d
589614	M-6-10	3/8	100	3,300	3.9	2.4	0.43		0.44			
589615	M-86-10	1/2	100	7,000	4.7	2.8	0.55		0.88			
589616	M-108-10	5/8	100	11,400	5.5	3.1	0.67		1.8			
589617	M-13-10	3/4	100	12,300	5.9	3.5	0.75		2.2			
589618	M-1310-10	7/8	100	17,200	6.3	3.7	0.87		3.3			
589619	M-1613-10	1	100	29,900	7.5	4.3	1.1		5.1			
589620	M-19-10	1 1/4	100	35,200	7.9	4.7	1.2		7.7			
589621	M-2016-10	1 3/8	100	45,300	9.4	5.5	1.3		11.7			
589622	M-2220-10	1 1/2	100	68,000	9.8	5.9	1.6		16.1			
589623	M-2622-10	1 5/8	100	70,400	9.8	5.9	1.7		17.2			
589624	M-32-10	1 3/4	100	84,900	11.8	7.1	1.8		26.4			
589625	M-3226-10	2	100	102,600	11.8	7.9	2.0		33.1			
589626	M-3632-10	2 1/4	100	143,100	13.8	7.9	2.2		46.3			
589627	M-4536-10	2 1/2	100	160,000	14.8	8.3	2.4		57.3			
589628	M-90T-10	2 3/4	100	220,200	17.7	9.8	2.8		94.8			
589629	M-125T-10	3 1/4	100	275,300	17.7	10.2	3.1		125.6			
589630	MT-6-10	3/4	100	11,000	5.9	3.5	0.75	10.6	4.7	2.8	0.55	4.0
589631	MT-8-10	7/8	100	17,600	6.3	3.7	0.87	11.8	5.5	3.1	0.67	6.6
589632	MT-9-10	1	100	21,300	7.5	4.3	1.1	13.4	5.9	3.5	0.75	9.5
589633	MT-10-10	1 1/4	100	35,200	7.9	4.7	1.2	14.2	6.3	3.7	0.87	14.3
589634	MT-13-10	1 5/8	100	57,200	9.8	5.9	1.6	17.3	7.5	4.3	1.1	30.0
589635	MT-16-10	2	100	77,000	11.8	7.9	2.0	19.7	7.9	4.7	1.3	50.7
589636	MT-20-10	2 1/4	100	110,100	11.8	7.9	2.2	21.7	9.8	5.9	1.6	69.4
589637	MT-22-10	2 1/2	100	165,100	13.8	7.9	2.4	24.0	10.2	5.5	1.8	101.4
589638	MT-26-10	2 3/4	100	220,200	17.7	9.8	2.8	28.7	11.0	6.3	2.0	156.5
589639	MT-32-10	3 1/4	100	275,300	17.7	10.2	3.1	29.5	11.0	6.3	2.2	200.6

\* Design Factor 5:1, Proof tested to 2 times Working Load Limit

\*\* Subassemblies Contain Engineered Flats

Working Load Limit for Single Leg Sling

M & MT master link series replace the O & OT master link series



SEE WARNINGS AND USE LIMITATIONS ON PAGES 26-36

## TYPE M MASTER LINK SELECTION TABLE FOR GRADE 80 ALLOY CHAIN SLINGS WITH 1 OR 2 LEGS

Stock Number	MASTER LINK TRADE SIZE		MODEL	Chain Size 1-LEG 90°		Working Load Limit (Lbs)*	Chain Size 2-LEG 60°		Working Load Limit (Lbs)*
	IN	MM		IN	MM		IN	MM	
589614	3/8	11	M-6-10	7/32"	6	2,100	-	-	-
589615	1/2	14	M-86-10	9/32"	7	3,500	-	-	-
589615	1/2	14	M-86-10	5/16"	8	4,500	7/32"	6	3,600
589616	5/8	17	M-108-10	3/8"	10	7,100	9/32"	7	6,100
589616	5/8	17	M-108-10	-	-	-	5/16"	8	7,800
589617	3/4	19	M-13-10	1/2"	13	12,000	3/8"	10	12,300
589619	1	25	M-1613-10	5/8"	16	18,100	1/2"	13	20,800
589620	1 1/4	30	M-19-10	3/4"	20	28,300	5/8"	16	31,300
589622	1 1/2	38	M-2220-10	7/8"	22	34,200	3/4"	20	49,000
589623	1 5/8	40	M-2622-10	1"	26	47,700	7/8"	22	59,200
589625	2	50	M-3226-10	1 1/4"	32	72,300	1"	26	82,600
589626	2 1/4	55	M-3632-10	-	-	-	1 1/4"	32	125,200

\* Design factor 4:1

## TYPE M MASTER LINK SELECTION TABLE FOR GRADE 80 ALLOY CHAIN SLINGS WITH 1 OR 2 LEGS

Stock Number	MASTER LINK TRADE SIZE		MODEL	Chain Size 1-LEG 90°		Working Load Limit (Lbs)*	Chain Size 2-LEG 60°		Working Load Limit (Lbs)*
	IN	MM		IN	MM		IN	MM	
589614	3/8	11	M-6-10	7/32"	6	2,700	-	-	-
589615	1/2	14	M-86-10	9/32"	7	4,300	-	-	-
589615	1/2	14	M-86-10	5/16"	8	5,700	7/32"	6	4,700
589616	5/8	17	M-108-10	3/8"	10	8,800	9/32"	7	7,400
589616	5/8	17	M-108-10	-	-	-	5/16"	8	9,900
589617	3/4	19	M-13-10	1/2"	13	15,000	-	-	-
589618	7/8	22	M-1310-10	-	-	-	3/8"	10	15,200
589619	1	25	M-1613-10	5/8"	16	22,600	1/2"	13	26,000
589620	1 1/4	30	M-19-10	3/4"	20	35,300	-	-	-
589621	1 3/8	34	M-2016-10	7/8"	22	42,700	5/8"	16	39,100
589623	1 5/8	40	M-2622-10	-	-	-	3/4"	20	61,000
589623	1 5/8	40	M-2622-10	1"	26	59,700	-	-	-
589624	1 3/4	45	M-32-10	-	-	-	7/8"	22	74,000
589626	2 1/4	55	M-3632-10	-	-	-	1"	26	103,400

\* Design factor 4:1

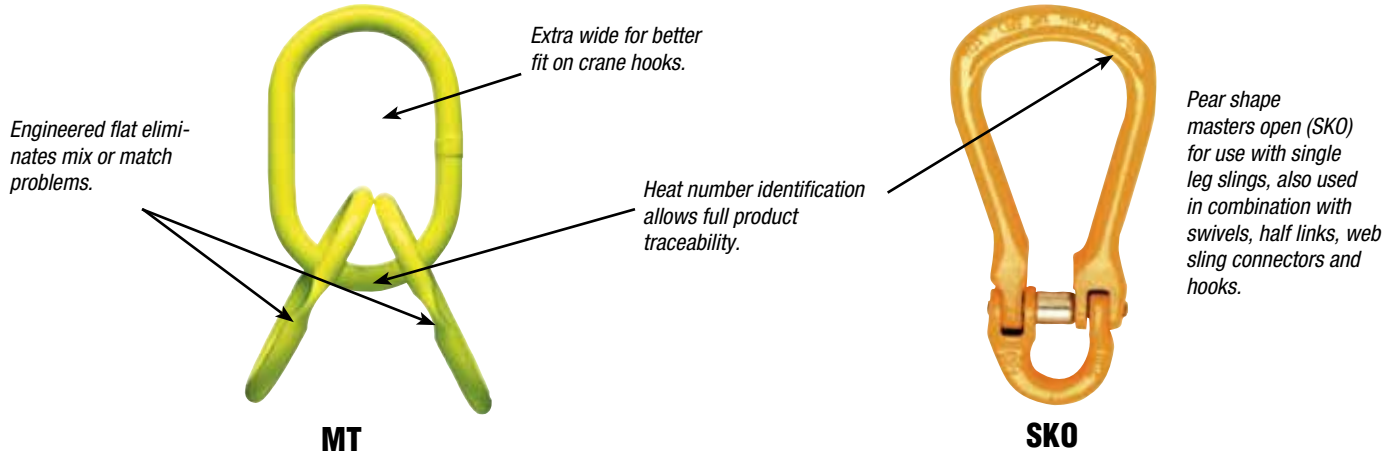

## TYPE MT MASTER LINK SELECTION TABLE FOR GRADE 80 ALLOY CHAIN SLINGS WITH 3 OR 4 LEGS

Stock No.	MASTER LINK TRADE SIZE		MODEL	Chain Size 3 OR 4 LEG 60°		Working Load Limit (Lbs)*
	IN	MM		IN	MM	
589630	3/4	19	MT-6-10 **	7/32	6	5,500
589631	7/8	22	MT-8-10 **	9/32"	7	9,100
589631	7/8	22	MT-8-10 **	5/16"	8	11,700
589632	1	25	MT-9-10	3/8"	10	18,400
589633	1 1/4	30	MT-10-10 **	1/2"	13	31,200
589634	1 5/8	40	MT-13-10 **	5/8"	16	47,000
589635	2	50	MT-16-10 **	3/4"	20	73,500
589636	2 1/4	55	MT-20-10 **	7/8"	22	88,900
589637	2 1/2	60	MT-22-10	1"	26	123,900
589638	2 3/4	70	MT-26-10	1 1/4"	32	187,800
589639	3 1/4	80	MT-32-10	1 1/4"	32	187,800

\* Design factor 4:1    \*\* Subassemblies have engineered flats

## TYPE MT MASTER LINK SELECTION TABLE FOR GRADE 100 ALLOY CHAIN SLINGS WITH 3 OR 4 LEGS

Stock No.	MASTER LINK TRADE SIZE		MODEL	Chain Size 3 OR 4 LEG 60°		Working Load Limit (Lbs)*
	IN	MM		IN	MM	
589630	3/4	19	MT-6-10 **	7/32	6	7,000
589631	7/8	22	MT-8-10 **	9/32"	7	11,200
589632	7/8	22	MT-8-10 **	5/16"	8	14,800
589633	1 1/4	30	MT-10-10 **	3/8"	10	22,900
589634	1 5/8	40	MT-13-10 **	1/2"	13	39,000
589635	2	50	MT-16-10 **	5/8"	16	58,700
589636	2 1/4	55	MT-20-10 **	3/4"	20	91,700
589637	2 1/2	60	MT-22-10	7/8"	22	110,900
589639	3 1/4	80	MT-32-10	1"	26	155,100

\* Design factor 4:1    \*\* Subassemblies have engineered flats

## OPEN MASTER LINKS - SKO WITH HALF LINKS

Stock No.	Model	Chain Size In.	Grade	Working Load Limit *(Lbs)	Dimensions (Inches)					Working Load Limit (Lbs)*
					L	L1	B	G	B1	
545421	SKO-7/8-8 w/ SKT	9/32"	80	3,500	3.9	5.0	2.0	0.55	0.59	0.88
545421	SKO-7/8-8 w/ SKT	5/16"	80	4,500	3.9	5.0	2.0	0.55	0.59	0.88
545422	SKO-10-8 w/ SKT	3/8"	80	7,100	5.0	6.3	2.6	0.71	0.79	1.8
545423	SKO-13-8 w/ SKT	1/2"	80	12,000	5.7	7.4	2.8	0.87	1.0	3.1
545424	SKO-16-8 w/ SKT	5/8"	80	18,100	6.9	8.9	3.2	1.0	1.2	5.1
545425	SKO-18/20-8 w/ SKT	3/4"	80	28,300	8.0	10.5	4.1	1.2	1.4	8.2

\* Design Factor 4:1 Proof tested and certified.

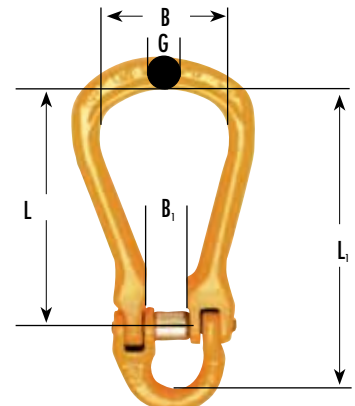

SEE WARNINGS AND USE LIMITATIONS ON PAGES 26-36

Pear shape masters closed (SKG) for use with single leg slings, also used in combination with swivels, half links, web sling connectors and hooks.



**SKG**

Heat number identification allows full product traceability.

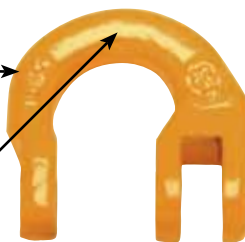

Replacement 1/2 connector for master links, hooks, connectors and swivels.

Stainless Steel spring.



**SKT**

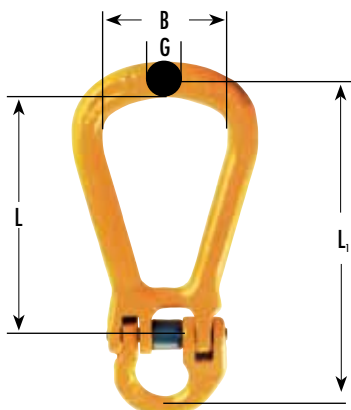

## CLOSED MASTER LINKS - SKG WITH HALF LINKS

Stock No.	Model	Chain Size In.	Grade	Working Load Limit *(Lbs)	L	Dimensions (Inches)			Weight Each (Lbs.)
						L1	B	G	
512620	SKG-7/8-8 w/ SKT	9/32"	80	3,500	3.9	5.0	2.0	0.55	0.88
512620	SKG-7/8-8 w/ SKT	5/16"	80	4,500	3.9	5.0	2.0	0.55	0.88
512630	SKG-10-8 w/ SKT	3/8"	80	7,100	5.0	6.3	2.6	0.71	1.8
512650	SKG-13-8 w/ SKT	1/2"	80	12,000	5.7	7.4	2.8	0.87	3.3
512680	SKG-16-8 w/ SKT	5/8"	80	18,100	6.9	8.9	3.2	1.0	5.3
512700	SKG-18/20-8 w/ SKT	3/4"	80	28,300	8.0	10.5	4.1	1.2	8.6

\* Design Factor 4:1 Proof tested and certified.

## HALF LINK WITH PIN/LOCK WASHER GRADE 80

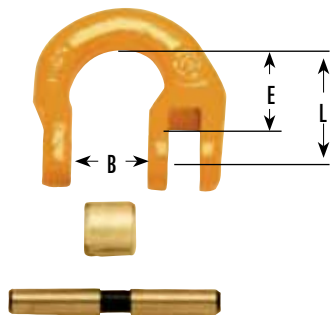

Stock No.	Model	Chain Size In.	Grade	Working Load Limit *(Lbs)	L	Dimensions (Inches)			Weight Each (Lbs.)
						B	G	E	
545931	SKT-7/8-8	9/32"	80	3,500	1.1	0.71	0.35	0.87	0.22
545931	SKT-7/8-8	5/16"	80	4,500	1.1	0.71	0.35	0.87	0.22
545932	SKT-10-8	3/8"	80	7,100	1.3	1.0	0.5	1.0	0.44
545933	SKT-13-8	1/2"	80	12,000	1.7	1.1	0.6	1.3	0.88
545934	SKT-16-8	5/8"	80	18,100	2.0	1.4	0.7	1.6	1.5
545935	SKT-18/20-8	3/4"	80	28,300	2.5	1.7	0.9	1.9	2.4
545226	SKT-22-8	7/8"	80	34,200	3.0	2.0	0.9	2.4	3.7
545227	SKT-26-8	1"	80	47,700	3.1	2.3	1.1	2.4	5.7
545228	SKT-32-8	1 1/4"	80	72,300	3.9	2.8	1.4	3.1	10.8

\* Design Factor 4:1 Proof tested and certified.

Note: G80 SKT for use with G80 SKLI, SKO, SKG, SKS, SKR, SKH, SKN & G-Link only



Forged Grade 80 Alloy Steel



**WLP**

Heat number identification allows full product traceability.

Large radius improves efficiency of synthetic slings.

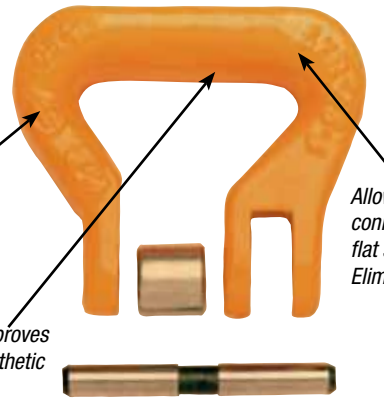

**SKR**

Allows a variety of connections to round or flat synthetic slings. Eliminates bunching effect.

## WELD-ON LIFTING POINT - WLP

Stock No.	Model	Chain Size In.	Grade	Working Load Limit *(Lbs)	Dimensions (Inches)							Weight Each (Lbs.)
					B	D	G	H	L	R	T	
589422	WLP-1 TON	1	80	2,200	2.0	0.55	1.1	1.5	2.1	0.94	3.7	1.1
589423	WLP-3 TON	3	80	6,600	2.3	0.67	1.3	1.9	1.9	1.1	3.8	2.0
589424	WLP-5 TON	5	80	11,000	2.5	0.87	1.6	2.4	2.9	1.3	5.3	3.7

\* Design Factor 4:1 Proof tested and certified.

Welding instructions included. For welding use electrode AWS A 5.1 E 7018.

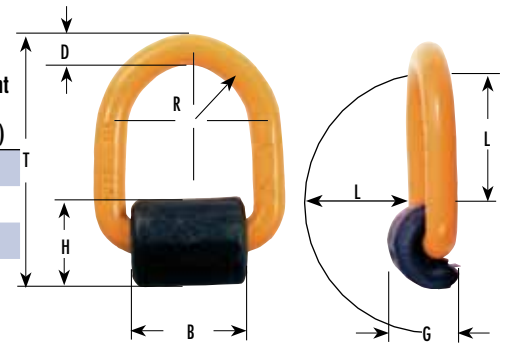

## WEB ROUND SLING CONNECTOR - SKR

Stock No.	Model	Chain Size In.	Grade	Working Load Limit *(Lbs)	Dimensions (Inches)				Weight Each (Lbs.)
					L	B	K	S	
545591	SKR-7/8-8	9/32"	80	3,500	1.4	1.6	0.71	0.94	0.44
545591	SKR-7/8-8	5/16"	80	4,500	1.4	1.6	0.71	0.94	0.44
545592	SKR-10-8	3/8"	80	7,100	1.7	1.9	0.94	1.1	0.88
545593	SKR-13-8	1/2"	80	12,000	2.0	2.1	1.1	1.4	1.5
545594	SKR-16-8	5/8"	80	18,100	2.4	2.6	1.4	1.7	2.6
545595	SKR-18/20-8	3/4"	80	28,300	2.8	3.1	1.7	2.0	4.2
545596	SKR-22-8	7/8"	80	34,200	4.4	4.9	2.0	2.8	11.7
545597	SKR-26-8	1"	80	47,700	5.1	5.9	2.3	3.4	19.8

\* Design Factor 4:1 Proof tested and certified.

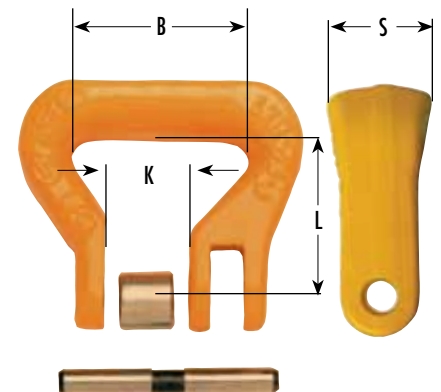

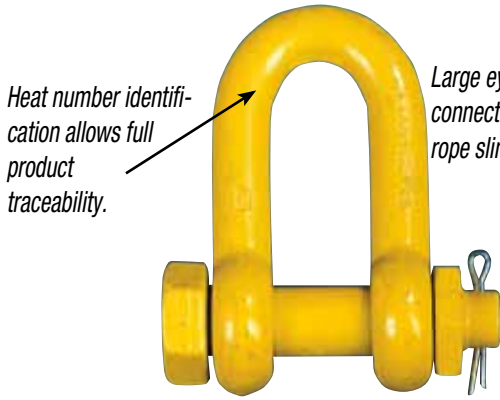

**SA**

Large eye for easy connection to wire rope slings.



**CH-3**

Heat number identification allows full product traceability.

Clevis assures correct chain size to shackle connection.

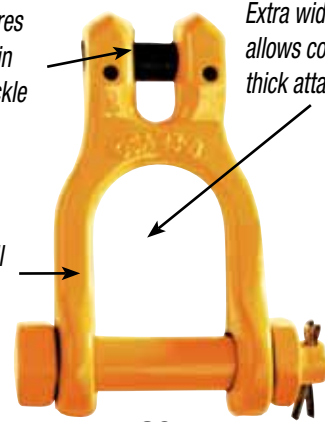

**GSA**

Extra wide shackle allows connection to thick attachments.

## SA SHACKLE - SA

Stock No.	Model	Chain Size In.	Grade	Working Load Limit *(Lbs)	Dimensions (Inches)					Weight Each (Lbs.)
					A (b)	C (l)	D	D1 (m)	D2 (g)	
589532	SA-7/8-8	9/32"	80	3,500	0.59	1.2	0.31	0.39	0.79	0.22
589532	SA-7/8-8	5/16"	80	4,500	0.59	1.2	0.31	0.39	0.79	0.22
551010	SA-10-8	3/8"	80	7,100	0.94	2.0	0.51	0.63	1.4	0.88
551013	SA-13-8	1/2"	80	12,000	1.1	2.6	0.63	0.79	1.7	1.5
551016	SA-16-8	5/8"	80	18,100	1.2	2.8	0.71	0.87	1.8	2.2
551019	SA-19-8	3/4"	80	28,300	1.4	3.4	0.87	1.1	2.2	4.0
551022	SA-22-8	7/8"	80	34,200	1.6	3.7	1.0	1.2	2.4	5.5
551026	SA-26-8	1"	80	47,700	1.9	4.6	1.3	1.5	3.0	11.5

\* Design Factor 4:1 Proof tested and certified.

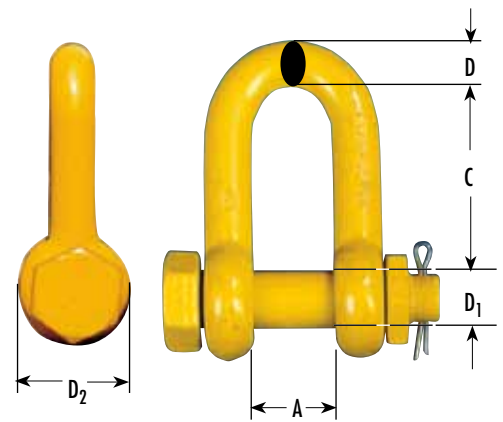

## CONTAINER LIFTING HOOKS - CH

Stock No.	Model	Size	Grade	Working Load Limit *(Lbs)	Dimensions (Inches)						Weight Each (Lbs.)
					L	B	H	F	E	G	
590341	CH-3 Straight	S	100	27,500	7.6	2.8	1.8	1.0	3.0	1.9	8.8
590342	CH-3 Right	L	100	27,500	7.6	2.8	1.8	1.0	3.0	1.9	8.8
590343	CH-3 Left	R	100	27,500	7.6	2.8	1.8	1.0	3.0	1.9	8.8

\* Design Factor 4:1 Proof tested and certified.

Left hook marked with "V" Right hook marked with "H"

Note: CH-3 Container Lifting Hooks intended for use as part of a spreader beam lifting system.

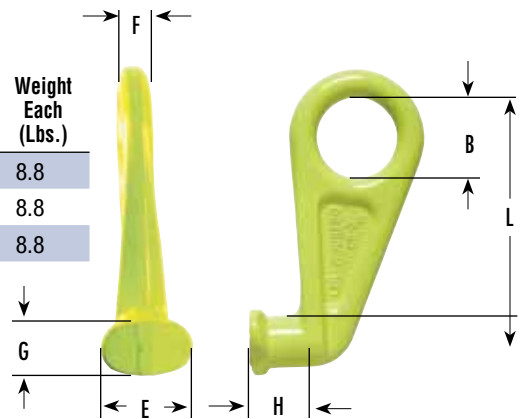

## CLEVIS SHACKLE - GSA

Stock No.	Model	Chain Size In.	Grade	Working Load Limit *(Lbs)	Dimensions (Inches)						Weight Each (Lbs.)
					A	B	C	G	L	M	
551032	GSA-7/8-8	9/32"	80	3,500	1.4	1.3	3.1	1.3	2.4	0.63	1.1
551032	GSA-7/8-8	5/16"	80	4,500	1.4	1.3	3.1	1.3	2.4	0.63	1.1
551033	GSA-7/8-8	3/8"	80	7,100	1.9	1.3	3.7	1.6	3.1	0.79	2.0
551034	GSA-7/8-8	1/2"	80	12,000	2.6	2.0	4.6	1.7	3.9	0.87	3.7
551035	GSA-7/8-8	5/8"	80	18,100	2.8	2.4	5.6	2.1	4.5	1.1	6.6

\* Design Factor 4:1 Proof tested and certified.

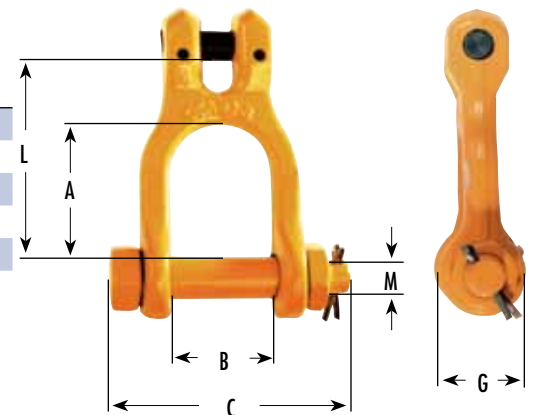

## COUPLING PIN/LOCK WASHER SET, GRADE 100

## Spare Parts

GJC Stock No.	Article No.	Model	Hook Size (mm)	Size (Inch)	Grade	Weight Each (Lbs.)
589777	Z100933	SKA-7/8-10	7	9/32"	100	0.04
589777	Z100933	SKA-7/8-10	8	5/16"	100	0.04
589779	Z100934	SKA-10-10	10	3/8"	100	0.1
589780	Z100990	SKA-13-10	13	1/2"	100	0.2
589781	Z100991	SKA-16-10	16	5/8"	100	0.3
589783	Z101176	SKA-20-10	20	3/4"	100	0.6
589784	Z650555	SKA-22-10	22	7/8"	100	0.8
589887	Z650556	SKA-26-10	26	1"	100	1.4

*FITS GRADE 100:*

G Coupling Links    SKR Web/Round Sling Couplings    SKO Master Links  
 SKG Master Links    SKI Insulated Ball Bearing Swivels    SK Sling Hooks  
 BKL-SK Safety Hooks    SKL Ball Bearing Swivels    SKT Half Links  
 LKN-SK Sling Hooks    SKS Shank Couplings

## OBK-GBK "GRIP LATCH" STYLE SELF-LOCKING HOOKS - RD, OBK, GBK

## COUPLING PIN/LOCK WASHER SET, GRADE 80

GJC Stock No.	Article No.	Model	Size (mm)	Size (inch)	Grade	Weight Each (Lbs.)
545231	Z323624	SKA-7/8-8	7	9/32"	80	0.04
545231	Z323624	SKA-7/8-8	8	5/16"	80	0.04
545232	Z318024	SKA-10-8	10	3/8"	80	0.09
545233	Z303822	SKA-13-8	13	1/2"	80	0.18
545234	Z303725	SKA-16-8	16	5/8"	80	0.31
545235	Z145048	SKA-18/20-8	18/20	3/4"	80	0.6
545236	Z133530	SKA-22-8	22	7/8"	80	0.8
545237	Z605407	SKA-26-8	26	1"	80	1.4
545238	Z650554	SKA-32-8	32	1 1/4"	80	2.3

*Proof tested and certified.*

*FITS GRADE 80:*

G Coupling Links    SKR Web/Round Sling Couplings    SKO Master Links  
 SKG Master Links    SKI Insulated Ball Bearing Swivels    SK Sling Hooks  
 BKL-SK Safety Hooks    SKL Ball Bearing Swivels    SKT Half Links  
 LKN-SK Sling Hooks    SKS Shank Couplings

GJC Stock No.	Article No.	Model	Hook Size (mm)	Hook Size (inch)	Weight Each (Lbs.)
511898	Z100281	RD OBK/GBK-6	6	7/32"	0.1
511811	Z100288	RD OBK/GBK-7/8	7	9/32"	0.1
511811	Z100288	RD OBK/GBK-7/8	8	5/16"	0.1
511821	Z100289	RD OBK/GBK-10	10	3/8"	0.1
511831	Z100290	RD OBK/GBK-13	13	1/2"	0.1
511841	Z100291	RD OBK/GBK-16	16	5/8"	0.4
590147	Z100297	RD BK/OBK-18/20	20	3/4"	0.6
589366	Z100323	RD OBK/GBK-22	22	7/8"	0.8

*Parts included (one each):*

- A) Release Trigger
- B) Stainless Steel Spring
- C) Spring Dowel Pin

## LOAD PIN WITH RETAINING PINS TYPE BLA FOR GRADE 80 CLEVIS FITTINGS

GJC Stock No.	Article No.	Model	Hook Size (mm)	Hook Size (Inch)	Weight Each (Lbs.)
545330	Z275649	BLA-6-8	6	7/32"	0.1
589524	Z100711	BLA-7-8 (GKL-7-8 only)	7	9/32"	0.1
545331	Z275347	BLA-7/8-8	7	9/32"	0.1
545331	Z275347	BLA-7/8-8	8	5/16"	0.1
545332	Z275444	BLA-10-8	10	3/8"	0.1
545333	Z275648	BLA-13-8	13	1/2"	0.1
545334	Z276047	BLA-16-8	16	5/8"	0.3
545335	Z276241	BLA-19/20-8	20	3/4"	0.6

*Proof tested and certified. \*Load Pin for GKL-7-8 only.*

*FITS:*    BKG Safety Hooks    GK Grab Hooks    BL Couplers    BKH 6-8    CEL  
           GBK Safety Hooks    GG Grab Hooks    BKH                    GKL

*\*Load Pin for GKL-7-8 only*

## LOAD PIN WITH RETAINING PIN TYPE CLS FOR GRADE 100 CLEVIS FITTINGS

GJC Stock No.	Article No.	Model	Hook Size (mm)	Hook Size (Inch)	Weight Each (Lbs.)
545331	Z275347	BLA-7/8-8	7	9/32"	0.1
589437	B14931	CLS-8-10	8	5/16"	0.1
589438	B14932	CLS-10-10	10	3/8"	0.1
589439	B14933R	CLS-13-10	13	1/2"	0.2
589504	B14934	CLS-16-10	16	5/8"	0.2
590331	B14935	CLS-20-10	20	3/4"	0.3

*Design Factor 4:1*

*FITS Grade 100 GG, EGK, EGKN, BKG, AND GBK FITTINGS*



## Spare Parts

### REPLACEMENT TRIGGERS FOR BK HOOKS

#### New Style Grade 80/100 Hooks

Size (In)	Size (mm)	G10 BK RT Hook	Replacment Trigger	GJC Part Number
7/32"	6	BK-6-10 BKL-6-10 BKLK-6-10 BKH-6-10	Z100282	590140
9/32"	7	BKG-7-10	Z100283	590142
5/16"	7/8	BK-7/8-10 BKL-7/8-10 BKLK-7/8-10 BKH-7/8-10	Z100283	590142
5/16"	8	BKG-8-10	Z100283	590142
3/8"	10	BK-10-10 BKG-10-10 BKL-10-10 BKLK-10-10	Z100284	590144
1/2"	13	BK-13-10 BKG-13-10 BKL-13-10 BKLK-13-10	Z100285	590145
5/8"	16	BK-16-10 BKG-16-10 BKL-16-10 BKLK-16-10	Z100286	590146
3/4"	20	BK-18/20-10 BKG-20-10 BKL-18/20-10 BKLK-18/20-10	Z100297	590147
7/8"	22	BK-22-10 BKLK-22-10	Z100287	590360
1"	26	BK-26-8	Z100280	590361
1"	26	BK-26-10 BKLK-26-10	Z100295	590148
1 1/4"	32	BK-32-8 BKLK-32-8	Z100294	590481

### OLD STYLE GRADE 80 HOOKS WITHOUT RECESSED TRIGGERS

#### Old Style Grade 80 Hooks

Size (In)	Size (mm)	G8 BK Non RT Hook	Replacment Trigger	GJC Part Number
7/32"	6	BK-6-8 BKL-6-8 BKLK-6-8 BKH-6-8 BKT-6-8	Z100282	590140
9/32"	7	N/A		
5/16"	7/8	BK-7/8-8 BKG-7/8-8 BKL-7/8-8 BKLK-7/8-8 BKH-7/8-8 BKT-7/8-8	Z100283	590142
5/16"	8	N/A		
3/8"	10	BK-10-8 BKG-10-8 BKL-10-8 BKLK-10-8 BKT-10-8 BKB-10-8	Z100284	590144
1/2"	13	BK-13-8 BKG-13-8 BKL-13-8 BKLK-13-8 BKT-13-8	Z100285	590145
5/8"	16	BK-16-8 BKG-16-8 BKL-16-8 BKLK-16-8 BKT-16-8	Z100286 *	590146
3/4"	20	BK-18/20-8 BKG-19/20-8 BKL-18/20-8 BKLK-18/20-8	Z100297	590147
7/8"	22	BK-22-8	Z100287	590360
1"	26	BK-26-8	Z100280	590361
1 1/8"	28	BK-28-8	Z100292	589375

\* Gunnebo Johnson Corp. Part Number 590146 can not be used to repair BK, BKL, & BKLK-16-8 hooks produced before January 1, 2000. Spare parts are no longer available for these hooks.

### SHORTENING CLUTCH - RDGKL

### LATCH KIT FOR GKN

### LATCH KIT FOR SKN

GJC Stock No.	Article No.	Model	Hook Size (mm)	Hook Size (Inch)	Weight Each (Lbs.)	GJC Stock No.	Article No.	Model	Hook Size (mm)	Hook Size (Inch)	Weight Each (Lbs.)	GJC Stock No.	Article No.	Model	Hook Size (mm)	Hook Size (Inch)	Weight Each (Lbs.)
589360	Z100317	RD GKL-6-8	6	7/32"	0.1	545960	Z622175	RD GKN/OKN-7/8-8	7	9/32"	0.1	545951	Z420581	RD SKN/LKN/LKKN-7/8-8	7	9/32"	0.1
589361	Z100318	RD GKL-7-8	7	9/32"	0.1	545960	Z622175	RD GKN/OKN-7/8-8	8	5/16"	0.1	545951	Z420581	RD SKN/LKN/LKKN-7/8-8	8	5/16"	0.1
589361	Z100318	RD GKL-8-8	8	5/16"	0.1	545961	Z622183	RD GKN/OKN-10-8	10	3/8"	0.2	545952	Z420688	RD SKN/LKN/LKKN-10-8	10	3/8"	0.2
545947	Z700805	RD GKL-10-8	10	3/8"	0.1	545962	Z622206	RD GKN/OKN-13-8	13	1/2"	0.3	545953	Z420785	RD SKN/LKN/LKKN-13-8	13	1/2"	0.3
589355	Z100319	RD GKL-13-8	13	1/2"	0.2	545963	Z622214	RD GKN-16-8	16	5/8"	0.5	545954	Z420989	RD SKN/OKN/LKN-16-8	16	5/8"	0.5
589363	Z100329	RD GKL-16-8	16	5/8"	0.3	589451	Z100453	RD GKN-19/EKN-18/20	20	3/4"	0.6	545955	Z421087	RD SKN/OKN-18/20-8	20	3/4"	0.6



## Spare Parts

### LATCH KIT FOR OKN

GJC Stock No.	Article No.	Model	Hook Size (mm)	Hook Size (Inch)	Weight Each (Lbs.)
545960	Z622175	RD GKN/OKN-7/8-8	7	9/32"	0.1
545960	Z622175	RD GKN/OKN-7/8-8	8	5/16"	0.1
545961	Z622183	RD GKN/OKN-10-8	10	3/8"	0.2
545962	Z622206	RD GKN/OKN-13-8	13	1/2"	0.3
545954	Z420989	RD SKN/OKN/LKN-16-8	16	5/8"	0.5
545955	Z421087	RD SKN/OKN-18/20-8	20	3/4"	0.6
545956	Z700698	RD OKN-22-8	22	7/8"	1.1
545957	Z700697	RD OKN-26-8	26	1"	1.3
545967	Z700794	RD OKN-32-8	32	1 1/4"	1.5

### LATCH KIT FOR EKN/ESKN/EGKN/LKN (NEW STYLE\*) AND/LKNK (NEW STYLE\*)

GJC Stock No.	Article No.	Model	Hook Size (mm)	Hook Size (Inch)	Weight Each (Lbs.)
589447	Z100447	RD EKN-7/8	7	9/32"	0.1
589447	Z100447	RD EKN-7/8	8	5/16"	0.1
589448	Z100450	RD EKN-10	10	3/8"	0.2
589449	Z100449	RD EKN-13	13	1/2"	0.3
589450	Z100217	RD EKN-16	16	5/8"	0.4
589451	Z100453	RD GKN-19/EKN-18/20	20	3/4"	0.6
589452	Z100452	RD EKN-22	22	7/8"	0.8
589537	Z100742	RD EKN-26	26	1"	1.3
589538	Z100743	RD EKN-32-8	32	1 1/4"	1.5

\*New style LKN & LKNK have notched hook tip and notched latch.

### CHAIN SLING IDENTIFICATION TAGS



**Stock Number**  
547302



**Stock Number**  
547303



**Stock Number**  
680095

### LATCH KIT FOR UKN WELD-ON HOOKS

GJC Stock No.	Article No.	Model	Hook Size (mt)	Weight Each (Lbs.)
589365	Z100258	RD UKN-.75 msp	0.75	0.1
545828	Z700264	RD UKN-1 msp	1	0.1
589358	Z700958	RD UKN-2 msp	2	0.4
589575	Z700266	RD UKN-3 / 4 msp	3	0.4
589575	Z700266	RD UKN-3 / 4 msp	4	0.4
589576	Z700268	RD UKN-5 / 8 msp	5	0.8
589576	Z700268	RD UKN-5 / 8 msp	8	0.8
545827	Z700269	RD UKN-10 msp	10	1.9
589604	Z700984	RD UKN-15	15	2.7

UKN springs available separately.

### LATCH KIT FOR RH HOOK

GJC Stock No.	Article No.	Model	Hook Size (Mt. Ton)	Weight Each (Lbs.)
589446	Z100445	RD EKN-6	1	0.1
589447	Z100447	RD EKN-7/8	2	0.1
589448	Z100450	RD EKN-10	3	0.2
589449	Z100449	RD EKN 13	5	0.3

### LATCH KIT FOR BKD LATCHES

GJC Stock No.	Article No.	Model	Hook Size (mm)	Hook Size (Inch)	Weight Each (Lbs.)
590425	Z101157	RD BKD-13	13	1/2"	0.3
590426	Z101158	BD BKD-16	16	5/8"	0.4
590427	Z101159	RD BKD-20	20	3/4"	0.6





## Chain Sling Type Naming Code

Basic chain sling configurations are often described using a code. Naming conventions have many exceptions and may vary among manufactures.

1. First Letter often designates the number of legs or branches:

- S** Single leg with one branch
- D** Double leg with two branches
- T** Triple leg with three branches
- Q** Quadruple leg sling with four branches

2. Second letter normally designates the fitting at the top of the sling:

- O** Oblong shaped master link
- S** Sling hook
- G** Grab hook
- B** Basket with oblong master sling

3. Third letter or group of letters normally designates the fitting at the bottom of each branch. A few of the many possibilities are listed below.

- S** Sling hook
- G** Grab hook
- LK** Sliding choker
- BK** Self Locking
- F** Foundry hook

If **A** precedes the group of letters, then a device to adjust the length has been added. Adjusters can be either of two styles, Type A or Type B. Both are pictured.

Example: **ADOS** describes an **A**adjustable, **D**ouble Leg Sling with **O**blong master link on top and a **S**ling hook at the bottom of each leg or branch.



**SG**



**SOS**



**SOG**



**SOF**



**SOBK**



**SGG**



**SSS**



**SSG**



**ASOS**



**SOLK**



**DOS**



**DOG**



**DOF**



**DOBK**



**DOO**



**BS**



**ADOS**



**DOLK**



**TOS**

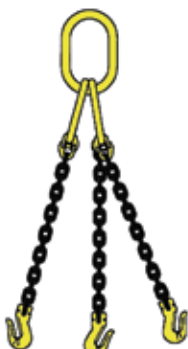

**TOG**



**TOF**



**TOBK**



**WARNING**

SEE WARNINGS AND USE LIMITATIONS ON PAGES 26-36



**ATOS**

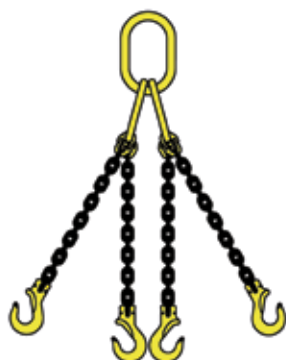

**QOS**



**QOG**



**QOF**



**QOBK**



**ENDLESS**



**AQOS**



**BD**



**TYPE A  
ADJUSTER**



**TYPE B  
ADJUSTER**

Tips for Chain Sling Assembly

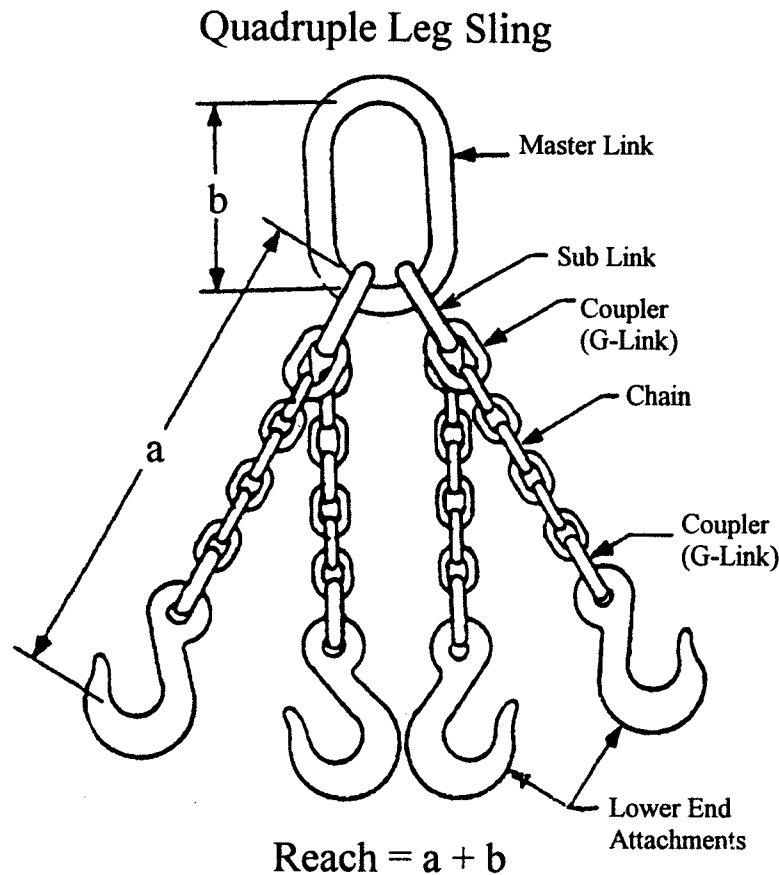

**1. Single Leg Sling:**

If the required measurement falls in the middle of a link, the next link is cut.

**2. Double Leg Sling  
(when assembling a clevis system sling)**

Cut chain to length and count the links. You must have an even number of links so hooks hang in the correct plane. (Hooks should always point out, as shown in diagram.)

**3. Triple or Quadruple Leg Sling  
(when assembling a clevis system sling)**

Cut chain to length and count the links. You must have an odd number of links so hooks hang in the correct plane. (Hooks should always point out, as shown in diagram.) If the measurement falls in the middle of a link, the next link is cut.

4. A metal I.D. Tag must always be attached to a chain sling, showing serial number, size, reach, rated capacity at angle of lift and manufacturer.
5. The reach of the sling is the length measured from the load bearing surface of the master link to the load bearing surface of the hook or lower terminal (as shown in illustration).
6. Each sling manufactured shall have a completed certificate of test provided to user.



## Alloy Steel Chain Sling Warnings and Use Limitations

This document contains warnings and use limitation information applicable to Gunnebo Lifting Grade 80 & Grade 100 Alloy Steel Chain Slings and components and is furnished with all Gunnebo Johnson Corporation shipments. Component distributors and lift system manufacturers must pass on this information in their warnings and use limitation literature where Gunnebo Lifting components are involved.

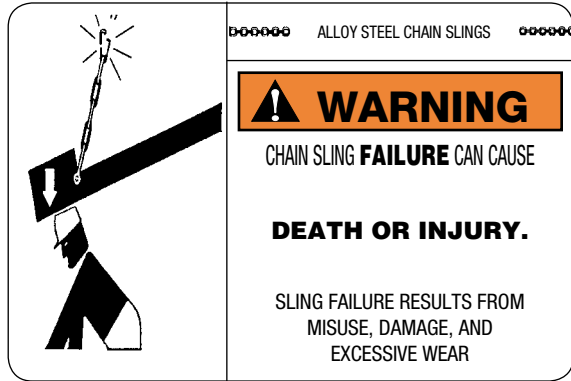

### Protect yourself and others:

- **Never** use a sling without training.
- **Always** inform yourself... Ask your employer for the manufacturer's sling use limitations.
- **Always** comply with applicable Federal and local regulations.
- **Always** know load weight.
- **Never** use a sling without a legible rated load tag.
- **Never** overload a sling.
- **Never** ride on sling or load.
- **Never** use an improper sling configuration.
- **Never** use a worn-out or damaged sling.
- **Never** use a sling in extreme temperatures.
- **Never** use a sling in acidic conditions.

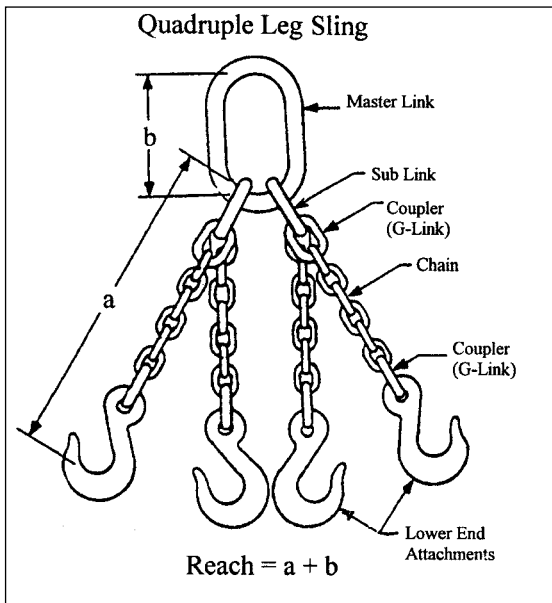

- **Never use a sling without training...** OSHA regulation requires responsible work practice.

“The employer shall permit only those employees qualified by training or experience to operate equipment or machinery” – OSHA 1926.20 (b)(4).

Employee training should include information given in OSHA training literature, ASME B30.9 – 2010 “Slings” and ASME B30.10 – 2009 “Hooks” safety standards, and this document.

- **Always inform yourself...** Ask your employer for chain sling safe use instruction.

“The employer shall instruct each employee in the recognition and avoidance of unsafe conditions and the regulations applicable to his work environment to control or eliminate any hazards or other exposure to illness or injury” – OSHA 1926.21 (b)(2).

- **Always comply with applicable Federal and local regulations ...** Federal and local regulations govern worksite activity.

Understand all governing laws and safety standards before use of chain slings. OSHA 1910.184 regulates chain sling safe operating practices, product identification, inspection requirements, and use limitations. ASME B 30.9-2010 “Sling” safety standard provides additional recommendations for chain sling use.

“If a particular standard is specifically applicable to a condition, practice, means, method, operation, or process, it shall prevail over any different general standard...” – OSHA 1910.5(c)(1).

Contact OSHA at (800) 321-6742, or [www.OSHA.gov](http://www.OSHA.gov) and ASME at (800) 843-2763, or [www.ASME.org](http://www.ASME.org) for reference assistance.

- **Always know load weight...** Avoid sling failure.

“The rated load of the sling shall not be exceeded.” – ASME B30.9-1.10.1 (c).

Weight of the load to be lifted must be known for determination of proper sling configuration and working load limit.

- **Never use a sling without a legible identification tag...** Sling Identification is required to ensure proper sling application.



“Alloy steel chain slings shall have permanently affixed durable identification stating size, grade, rated capacity, and reach.” - OSHA 1910.184 (e) (1)

“Hooks, rings...or other attachments shall have a rated capacity at least equal to that of the alloy steel chain with which they are used or the **slings shall not be used in excess of the rated capacity of the weakest component...**” – OSHA 1910.184 (e) (2) (i)

“Makeshift links or fasteners...shall not be used.” – OSHA 1910.184 (e) (2) (ii)

Gunnebo Johnson Corporation provides a blank identification tag, attached by a coupler, to be stamped with sling WLL, minimum working range angle, serial number, chain size, grade, reach, type and manufacturer. Order 547303 for replacement.

Grade of component with the **lowest breaking strength** shall be specified on the identification tag. Nonstandard grades shall be designated by “NS.”

Working Load Limit (WLL) is the maximum working load for a specified working range. Sling working range includes sling leg angles from 90° to a specified minimum. The specified minimum working range angle is given on the identification tag.

Working load is to be applied vertically to a sling assembly

having symmetric leg angles. WLL applies to loads lifted vertically and does not include torsional, binding, shock or non-symmetrical load effects.

Gunnebo Lifting Grade 80 & Grade 100 Alloy Steel Chain Straight Leg and Basket Sling Working Load Limits for selected working ranges of symmetric sling leg angles are listed in pounds and given in TABLE 1A & 1B. No chain sling shall be rigged with a leg angle less than 30° from the horizontal.

“Slings containing any Grade 80 components shall be rated at Grade 80 WLL’s.” ASTM A906/A 906M –02-9.2.

Double Leg and Single Basket Sling WLL for an alternate working range of symmetric sling leg angles equals (=) 2 x TABLE 1A or 1B single leg WLL x sine of the minimum working range angle.

Triple and Quadruple leg and Double Basket Sling WLL for an alternate working range of symmetric sling leg angles equals (=) 3 x TABLE 1A or 1B single leg WLL x sine of the minimum working range angle.

TABLE 2 lists for convenience sine values for selected sling leg angles.

Table 2

Angle	Sine	Angle	Sine	Angle	Sine
85	0.9962	70	0.9397	50	0.7660
80	0.9848	65	0.9063	40	0.6428
75	0.9659	55	0.8192	35	0.5736

Table 1A

**G80 ALLOY STEEL CHAIN SLING WORKING LOAD LIMITS\* IN POUNDS – DESIGN FACTOR OF 4**

G80 Chain Size		Single Leg	Double Leg				Triple & Quad Leg		
mm	in	90°	90° – 60°	90° – 45°	90° – 30°	90° – 60°	90° – 45°	90° – 30°	
6	7/32	2,100	3,600	3,000	2,100	5,450	4,450	3,150	
7	9/32	3,500	6,100	4,900	3,500	9,100	7,400	5,200	
8	5/16	4,500	7,800	6,400	4,500	11,700	9,500	6,800	
10	3/8	7,100	12,300	10,000	7,100	18,400	15,100	10,600	
13	1/2	12,000	20,800	17,000	12,000	31,200	25,500	18,000	
16	5/8	18,100	31,300	25,600	18,100	47,000	38,400	27,100	
19	3/4	25,500	44,100	36,000	25,500	66,200	54,000	38,200	
20	3/4	28,300	49,000	40,000	28,300	73,500	60,000	42,400	
22	7/8	34,200	59,200	48,400	34,200	88,900	72,500	51,300	
26	1	47,700	82,600	67,400	47,700	123,900	101,200	71,500	
32	1 1/4	72,300	125,200	102,200	72,300	187,800	153,400	108,400	

*Working Load Limits are valid between temperatures of –40°F and 400°F*

Table 1B

**G100 ALLOY STEEL CHAIN SLING WORKING LOAD LIMITS\* IN POUNDS – DESIGN FACTOR OF 4**

G100 Chain Size		Single Leg	Double Leg				Triple & Quad Leg		
mm	in	90°	90° – 60°	90° – 45°	90° – 30°	90° – 60°	90° – 45°	90° – 30°	
5.5	7/32	2,700	4,700	3,800	2,700	7,000	5,700	4,000	
7	9/32	4,300	7,400	6,100	4,300	11,200	9,100	6,400	
8	5/16	5,700	9,900	8,100	5,700	14,800	12,100	8,500	
10	3/8	8,800	15,200	12,400	8,800	22,900	18,700	13,200	
13	1/2	15,000	26,000	21,200	15,000	39,000	31,800	22,500	
16	5/8	22,600	39,100	32,000	22,600	58,700	47,900	33,900	
20	3/4	35,300	61,100	49,900	35,300	91,700	74,900	53,000	
22	7/8	42,700	74,000	60,400	42,700	110,900	90,600	64,000	
26	1	59,700	103,400	84,400	59,700	155,100	126,600	89,500	

Working Load Limits are valid between temperatures of -40°F and 400°F

Multi Leg and Basket Sling WLL for non-symmetrical loading can only be determined by engineering analysis of the specific rigging condition. In the absence of an engineering analysis, WLL shall be equal to single leg sling WLL given in TABLE 1A or 1B.

Choked chain sling WLL is affected by choke angle. TABLE 3A & 3B illustrates choke angle and gives Choked WLL's as a percentage of TABLE 1A & 1B WLL for full range of choke angles.

TABLE 3A GR 80

Choke Angle	Percentage Of TABLE 1A WLL
	120 - 180
90 - 119	87%
60 - 89	74%
30 - 59	62%
0 - 29	49%

TABLE 3B GR 100

Choke Angle	Percentage Of TABLE 1B WLL
	120 - 180
90 - 119	70%
60 - 89	60%
30 - 59	50%
0 - 29	40%

Choked Endless Chain Sling WLL's for selected Gunnebo Lifting Grade 80 and Grade 100 chain leg angles are listed in TABLE 4A and 4B.

TABLE 4A G80 - CHOKED ENDLESS CHAIN SLING WORKING LOAD LIMITS\* IN POUNDS - DESIGN FACTOR 4

G 80	CHAIN SIZE		CHOKED		
	MM	IN	ENDLESS		
			90°	90° - 60°	90° - 45°
	6	7/32	3150	2700	2250
	7	9/32	5250	4575	3675
	8	5/16	6750	5850	4800
	10	3/8	10600	9200	7500
	13	1/2	18000	15600	12700
	16	5/8	27100	23400	19200
	19	3/4	38200	33000	27000
	20	3/4	42400	36700	30000
	22	7/8	51300	44400	36300
	26	1	71500	61900	50500
	32	1 1/4	108400	93900	76600

\*Working Load Limits are valid between temperatures of -40° and 400°F

TABLE 4B G100 - CHOKED ENDLESS CHAIN SLING WORKING LOAD LIMITS\* IN POUNDS - DESIGN FACTOR 4

GUNNEBO LIFTING G 100	CHAIN SIZE		CHOKED		
	MM	IN	ENDLESS		
			90°	90° - 60°	90° - 45°
	5.5	7/32	4000	3500	2800
	7	9/32	6400	5500	4600
	8	5/16	8500	7400	6100
	10	3/8	13200	11400	9300
	13	1/2	22500	19500	15900
	16	5/8	33900	29300	24000
	20	3/4	52900	45800	37400
	22	7/8	64000	55500	45300
	26	1	89600	77600	63300

\*Working Load Limits are valid between temperatures of -40° and 400°F

**Never overload a sling ... Understand Working Load Limits.**

“Slings shall not be loaded in excess of their rated capacities.” - OSHA 1910.184 (c) (4).

“The design factor for alloy steel chain slings shall be a minimum of 4.” ASME B30.9-1.4.

Standard Gunnebo Lifting Working Load Limits (WLL) are based on a 4 design factor. Lift dynamics, duty cycle and hitch type may require an increased design factor, hence a reduced WLL. Inattention to required design factor can result in sling overload. Contact Gunnebo Johnson Corporation Service Department for assistance at (800) 331-5460.

Sling WLL depends on sling leg angle. The WLL for a sling is reduced as the sling leg angle with the horizontal gets smaller. This fact applies to all multi-leg and basket slings and must not be ignored.

The following diagram illustrates the effect of sling leg angle on the WLL for a single basket and 2-leg sling.

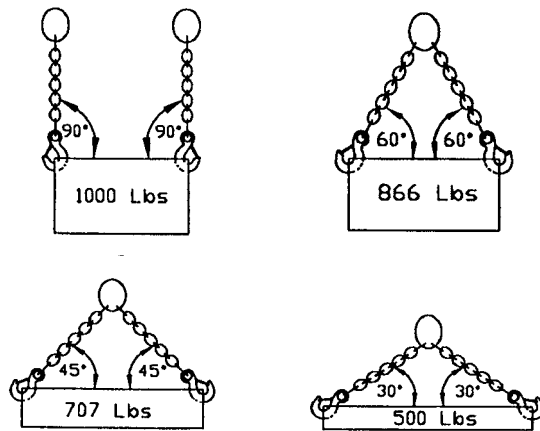

The WLL of a sling with a 30° leg angle is 50% of the WLL for the same sling with a 90° leg angle. Inattention to the effect of sling leg angle can result in sling overload.

Chain sling WLL is to be reduced in accordance with TABLE 5 when chain is rigged over an edge radius (R) less than two (2) x the chain rod diameter (d).

Reduced WLL equals chain sling WLL from identification tag x reduction factor.

TABLE 5 GR80 AND GR100

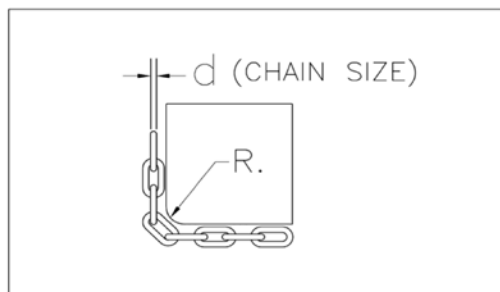

Edge Radius	R > 2 x Chain d	R > Chain d	R < Chain d
Reduction Factor	1.0	0.7	0.5

- **Never ride on sling or load ...** Avoid death or injury.

Sling use regulation requires: “All employees shall be kept clear of loads about to be lifted and of suspended loads.” - OSHA 1910.184 (c) (9).

General worksite regulations require “No hoisting, lowering, swinging or traveling shall be done while anyone is on the load or hook assembly.” - OSHA 1910.180 (h) (3) (v).

Construction worksite regulation stipulates: “The use of a crane or derrick to hoist employees on a personnel platform is *prohibited except* when the erection, use, and dismantling, of conventional means of reaching the worksite, such as a personnel hoist, ladder, stairway, aerial lift, elevating work platform or scaffold, would be *more hazardous* or is *not possible* because of structural design or worksite conditions.” - OSHA 1926.550 (g) (2).

Alloy steel chain slings shall not be used to rig personnel platforms.

- **Never rig a sling to a load improperly ...** Avoid dropped loads and sling damage.

“Safe operating practices ...” - OSHA 1910.184 (c)  
 “Operating practices ...” - ASME B30.9-1.10.

- Sling leg angle shall not be less than 30° from the horizontal.
- Slings shall be shortened with a shortening hook only and not with knots or bolts or other makeshift devices.
- Sling legs shall not be kinked or twisted.
- Sling hooks shall not be point loaded.
- Sling hook latch may be mandatory by regulation, safety codes, or insurance.
- Slings used in a basket hitch shall have the loads balanced to prevent slipping.
- Slings shall be securely attached to their loads.
- Slings shall be padded or protected from the edges of their loads when the edge radius is less than .5 of the chain rod diameter (d). See TABLE 5
- Sling shall be rigged to prevent chain from sliding over a load edge radius while lifting.

- **Never use a worn-out or damaged sling.**

“Each day before being used, the sling and all fastenings and attachments shall be inspected for damage or defects by a competent person designated by the employer. Additional inspections shall be performed during sling use where service conditions warrant. Damaged or defective slings shall be immediately removed from service” - OSHA 1910.184 (d).

“In addition to the inspection required by paragraph 1910.184 (d), a thorough periodic inspection shall be made on a regular basis, to be determined on the basis of (A) frequency of sling use; (B) severity of service conditions; (C) nature of lifts being made; and (D) experience gained on the service life of slings used in similar circumstances. Such inspections shall in no event be at intervals greater than once every 12 months.” - OSHA 1910.184 (e) (3) (i).

“The thorough inspection of alloy steel chain slings shall be performed by a competent person designated by the employer, and shall include a thorough inspection for wear, defective welds, deformation and increase in length. Where such defects or deterioration are present, the sling shall be immediately removed from service.” – OSHA 1910.184 (e) (3) (iii)

“Worn or damaged alloy steel chain slings or attachments shall not be used until repaired.” – OSHA 1910.184 (e) (7) (i).

Chain sling with reach longer than given on identification tag shall be immediately removed from service and evaluated for wear and material stretch.

Chain link wear is limited by minimum cross-sectional dimensions given in TABLE 6. Chain worn below the given limits shall be removed from service.

Chain Sling connector or attachment with wear greater than 10 percent of the original dimension for any cross-section shall be removed from service.

Chain sling coupler, chain, G-link, master ring, sub-link, hook or attachment that is broken, cracked, bent, stretched or twisted shall be removed from service and shall not be repaired.

Chain sling with a coupler, chain, G-link, master ring, sub-link, hook or attachment nicked or gouged or lapped shall be removed from service and shall not be returned to service unless properly repaired.

Hook latch, when required, shall be fully functional and properly seated.

TABLE 6 G80 AND G100

Nominal Chain or Coupling Link Size		Minimum Cross-Section Dimensional Limit	
mm.	in.	mm.	in.
6	7/32	5.2	.205
7	9/32	5.9	.239
8	5/16	6.9	.273
10	3/8	8.7	.342
13	1/2	11.3	.443
16	5/8	13.9	.546
19	3/4	16.3	.643
20	3/4	16.9	.665
22	7/8	19.0	.750
26	1	22.5	.887
32	1 1/4	27.7	1.091

- **Never use a sling in extreme temperatures.**

“...alloy steel chain slings shall be permanently removed from service if they are heated above 1000°F...” - OSHA 1910.184 (e) (6).

Alloy steel chain slings shall not be used while heated above 1000°F or cooled below -40°F.

Alloy steel chain sling Working Load Limits (WLL) given in TABLE 1A or 1B are valid between temperatures of -40°F and 400°F.

Alloy steel chain sling WLL shall be reduced in accordance with TABLE 7A and 7B when heated between 400°F and 1000°F.

Permanent WLL reduction shall be made in accordance with TABLE 7A and 7B for chain slings heated over temperatures indicated. Identification tag shall be replaced and the new tag shall have the reduced WLL.

TABLE 7A G80

Sling Component Temperature	Percentage of TABLE 1A and 4A WLL	
	During Exposure	After Exposure
-40°F to 400°F	None	None
>400°F to 500°F	95%	None
>500°F to 600°F	90%	None
>600°F to 700°F	82%	None
>700°F to 800°F	75%	90%
>800°F to 900°F	65%	75%
>900°F to 1000°F	60%	70%

TABLE 7B G100

Sling Component Temperature	Percentage of TABLE 1B and 4B WLL	
	During Exposure	After Exposure
-40°F to 400°F	None	None
>400°F to 500°F	95%	95%
>500°F to 600°F	90%	90%
>600°F to 700°F	82%	85%
>700°F to 800°F	75%	80%
>800°F to 900°F	65%	75%
>900°F to 1000°F	60%	70%

- **Never use a sling in alkaline or acidic conditions.**

Gunnebo Lifting Grade 80 & Grade 100 alloy steel chain and components shall not be used in alkaline or acidic conditions. Resulting metal embrittlement and accelerated corrosion can cause sudden sling failure. Hot dip galvanizing and electro-zinc plating of alloy steel chain and components shall be done only by Gunnebo Lifting.



## Alloy Steel BK Self-Locking Hook Warnings and Use Limitations

This document contains warnings and use limitation information applicable to Gunnebo Lifting G80 & G100 Alloy Steel BK self-locking hooks and is furnished with all Gunnebo Johnson Corporation shipments. Component distributors and lift system manufacturers must pass on this information in their Warnings and Use Limitation literature where Gunnebo Lifting BK self-locking hooks are involved.



⊙⊙⊙⊙⊙ ALLOY STEEL SELF-LOCKING HOOKS ⊙⊙⊙⊙⊙



**WARNING**

LOAD DISENGAGEMENT CAN CAUSE  
**DEATH OR INJURY**

DISENGAGEMENT RESULTS FROM  
MISUSE, DAMAGE, AND  
EXCESSIVE WEAR

### Protect yourself and others

- **NEVER** use a hook without training
  - **ALWAYS** inform yourself...Ask your employer for hook safe use instructions.
  - **ALWAYS** comply with applicable Federal and local regulations.
  - **ALWAYS** know hook load.
  - **NEVER** use a hook without a legible product identifier.
  - **NEVER** overload a hook.
  - **NEVER** ride on hook or load.
  - **NEVER** rig a hook to a load improperly.
  - **NEVER** use a worn-out or damaged hook.
  - **NEVER** use a hook in extreme temperatures.
  - **NEVER** use a hook in acidic conditions.
- **Never use a hook without training ...** OSHA regulation requires responsible work practice. "The employer shall permit only those employees qualified by training or experience to operate equipment or machinery" - OSHA 1926.20 (a) (4).

Employee training should include information given in OSHA training literature, ASME B30.9 - 2010 "Slings" and ASME B30.10 - 2009 "Hooks" safety standards and this document.

- **Always inform yourself ...** Ask your employer for hook safe use instruction.

"The employer shall instruct each employee in the recognition and avoidance of unsafe conditions and the regulations applicable to his work environment to control or eliminate

any hazards or other exposure to illness and injury" - OSHA 1926.21 (b) (2).

- **Always comply with applicable Federal and local regulations ...** Federal and local regulations govern worksite activity.

Understand all governing laws and safety standards before use of BK self-locking hooks. OSHA 1910.184 regulates sling safe operating practices, product identification, inspection requirements, and use limitations. The following safety standards provide additional recommendations for self-locking hook use.

ASME B30.9-2010 "Slings",  
ASME B30.10-2009 "Hooks",  
ASME B30.5-2011 "Mobile and Locomotive Cranes", ASME B30.16-2012 "Overhead Hoists (Underhung)", ASME B30.21-2010 "Manually Lever Operated Hoists".

"If a particular standard is specifically applicable to a condition, practice, means, method, operation, or process, it shall prevail over any different general standard..." - OSHA 1910.5 (c) (1).

Contact OSHA at (808) 321-6742, [www.OSHA.gov](http://www.OSHA.gov) and ASME at 800-843-2763, [www.ASME.org](http://www.ASME.org) for reference assistance.

- **Always know hook load ...** Avoid hook failure.

"Fittings shall be: (i) of a minimum breaking strength equal to that of the sling ..." - OSHA 1910.184 (i) (3) (i).

“It shall be determined that the weight of the load to be lifted does not exceed the lesser of the load rating of the hook or the load rating of the equipment of which the hook is a part.” - ASME B30.10-1.3 (a).

Maximum lift system load applied to self-locking hook must be known for proper self-locking hook selection.

- **Never use a hook without a legible product identifier ...** Product Identification is required to insure proper application.

“Hooks, rings ... or other attachments shall have a rated capacity at least equal to that of the alloy steel chain with which they are used or the sling shall not be used in excess of the rated capacity of the weakest component ...” - OSHA 1910.184 (e) (2) (i).

Gunnebo Lifting product identifier is forged into self-locking hook and is designated as (trade size)-(grade); Example: 13-8.

Gunnebo Lifting Grade 80 and Grade 100 Alloy Steel BK self-locking hook Working Load Limits for selected design factors are listed in pounds and given in TABLE 1A and TABLE 1B.

**TABLE 1A  
G80 ALLOY STEEL BK SELF-LOCKING HOOK  
WORKING LOAD LIMITS\***

BK HOOK		WORKING LOAD LIMIT*			
TRADE		IN POUNDS			
SIZE		DESIGN FACTOR			
MM	IN	4:1	5:1	6:1	9:1
5/6	7/32	2100	1680	1400	930
7/8	9/32	3500	2800	2330	1560
10	3/8	7100	5680	4730	3160
13	1/2	12000	9600	8000	5330
16	5/8	18100	14480	12070	8040
18/20	3/4	28300	22640	18860	12570
22	7/8	34200	27360	22800	15200
26	1	47700	38160	31800	21200
28	1 1/8	55100	44080	36700	24480
32	1 1/4	72300	57840	48200	32130

\*Working Load Limits are valid between temperatures of -40°F and 400°F.

**Never overload a hook ... Understand Working Load Limits.**

“Slings shall not be loaded in excess of their rated capacities.” - OSHA 1910.184 (c) (4).

Working Load Limit (WLL) is the maximum working load to be applied to a BK self-locking hook for the given application. WLL applies to in-line loading and does not include torsional, binding, shock or side load effects.

“The design factor for alloy steel chain slings shall be a minimum of 4.” - ASME B30.9 - 1.4.

**TABLE 1B  
G100 ALLOY STEEL BK SELF-LOCKING HOOK  
WORKING LOAD LIMITS\***

BK HOOK		WORKING LOAD LIMIT*			
TRADE		IN POUNDS			
SIZE		DESIGN FACTOR			
MM	IN	4:1	5:1	6:1	9:1
5/6	7/32	2700	2160	1800	1200
7/8	9/32	5700	4560	3800	2530
10	3/8	8800	7040	5860	3900
13	1/2	15000	12000	10000	6660
16	5/8	22600	18080	15060	10040
18/20	3/4	35300	28240	23530	15680
22	7/8	42700	34160	28460	18970
26	1	59700	47760	39800	26530

\*Working Load Limits are valid between temperatures of -40°F and 400°F.

“The design factor for wire rope slings shall be a minimum of 5” - ASME B30.9-2.4.

“The design factor for metal mesh slings shall be a minimum of 5.” - ASME B30.9-3.4.

“Increased design factors may be required for use with natural fiber ropes.”

“The design factor for synthetic rope slings shall be a minimum of 5.” - ASME B30.9-4.4.

The design factor for synthetic webbing slings shall be a minimum of 5. - ASME B30.9-5.4.

The design factor for round slings shall be a minimum of 5. - ASME B30.9-6.4.

Standard Gunnebo Lifting WLL’s are based on a 4 design factor. Lift dynamics, duty cycle and lift system type may require an increased design factor, hence a reduced WLL. Inattention to required design factor can result in hook overload. Contact Gunnebo Johnson Corp. Service Department for assistance at (800) 331-5460.

- **Never ride on hook or load ...** Avoid death or injury.

Sling use regulation requires: “All employees shall be kept clear of loads about to be lifted and of suspended loads.” - OSHA 1910.184 (c) (9).

General worksite regulations require “No hoisting, lowering, swinging or traveling shall be done while anyone is on the load or hook.” - OSHA 1910.180 (h) (3) (v).

Construction worksite regulation stipulates: “The use of a

crane or derrick to hoist employees on a personnel platform is *prohibited, except* when the erection, use, and dismantling, of conventional means of reaching the worksite, such as a personnel hoist, ladder, stairway, aerial lift, elevating work platform or scaffold, would be *more hazardous* or is *not possible* because of structural design or worksite conditions.” - OSHA 1926.1501(g) (2).

“Bridles and associated rigging for attaching the personnel platform to the hoist line shall be used only for the platform and the necessary employees, their tools and the materials necessary to do their work and shall not be used for any other purpose when not hoisting personnel.” - OSHA 1926.1501 (g) (4) (iv) (E).

Alloy steel BK self-locking hooks may be used to rig personnel platforms when lift system is in full compliance with OSHA 1926.1501(g) and TABLE 3.

- **Never rig a hook to a load improperly ...** Avoid dropped loads and hook damage.

“Safe operating practices ...” OSHA 1910.184 (c)

“Operating practices ...” ASME B30.5-3.2.

“Operating practices ...” ASME B30.9-1.10, 2.10, 3.10, 4.10, 5.10, 6.10.

“Operating practices ...”

- (c) Loads shall be centered in the base (bowl/ saddle) of hook to prevent point loading of the hook. (See Figure 1a, 1b & 1c)
- (d) Hooks shall not be used in such a manner as to place a side load or back load on the hook. (See Figure 2a & 2b)
- (e) When using a device to close the throat opening of the hook, care shall be taken that the load is not carried by the closing device. (See Figure 3a & 3b)
- (f) Hands, fingers and body shall be kept from between hook and load...
- (i) The use of a hook with a latch does not preclude the inadvertent detachment of a slack sling or a load from the hook. Visual verification of proper hook engagement is required in all cases.
- (j) Self-locking hooks shall be locked during use.
- (k) “When a hook is equipped with a latch, the latch should not be restrained from closing during use.” - ASME B30.10-1.3.

“Operation ...” - ASME B30.16-3.

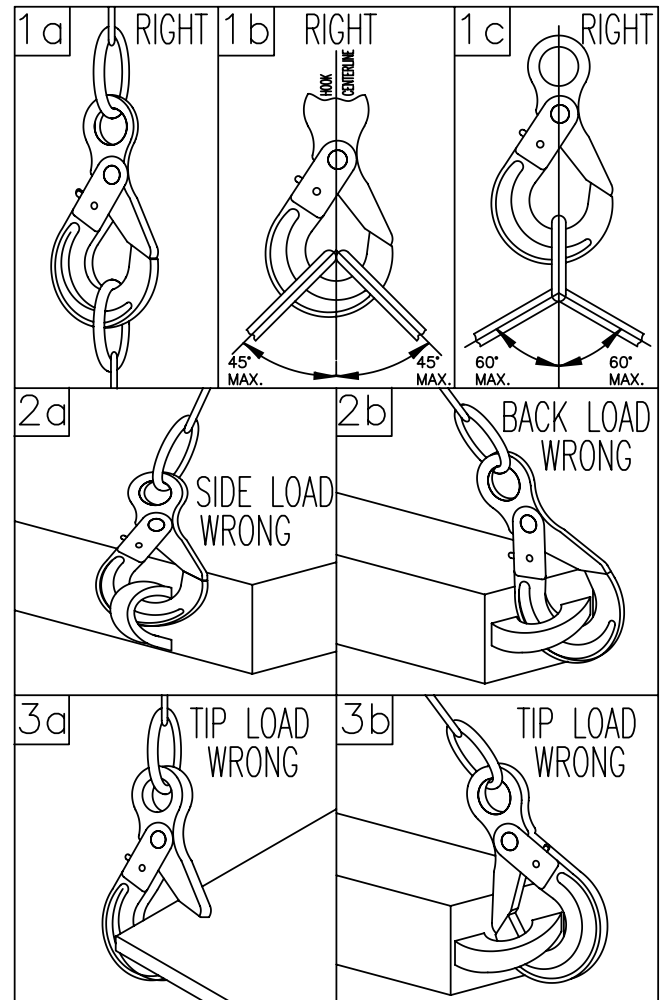

“Operation ...” - ASME B30.21-1.7; 2.6; 3.6.

Self-locking hooks shall not be rigged with more than two (2) sling legs in the hook saddle and sling leg angles shall not be greater than 45° from hook centerline. (Figure 1b)

Self-locking hooks shall be rigged with a master ring or shackle when three (3) or more sling legs are used or sling leg angles exceed 45° from hook centerline. (Figure 1c)

Synthetic slings may require a working load limit (WLL) reduction when used in self-locking hook eye or saddle. See synthetic sling manufacturers’ recommendations.

Chain sling WLL when choked with BK self-locking hooks equals 80% of sling identification tag WLL.

BKT self-locking hook shank machining limits are defined and are given in TABLE 2 and these limits are required for WLL's given in TABLE 1A and 1B. Failure to comply can result in stripped threads and loss of load.

Hook shank threads shall end with a thread relief. Hook shank shall not be swaged to wire rope or rod. Hook shank shall not be drilled and internally threaded.

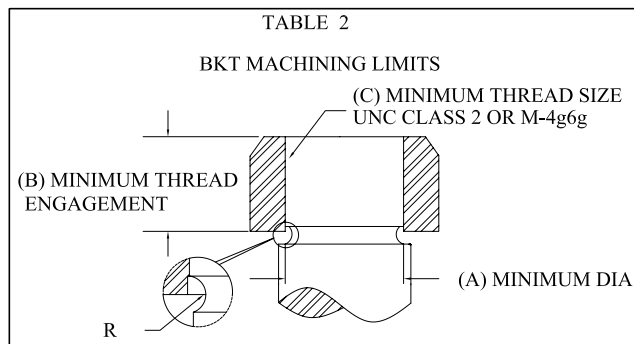

English				
Trade Size		(A)	(B)	(C) Min. Thread
MM	IN	Dia.	Len.	Class 2
5/6	7/32	.430	.563	9/16-12 UNC
7/8	9/32	.485	.625	5/8-11 UNC
10	3/8	.600	.750	3/4-10 UNC
13	1/2	.820	1.00	1-8 UNC
16	5/8	1.048	1.25	1-1/4-7 UNC
Metric				
Trade Size		(A)	(B)	(C) Min. Thread
MM	IN	Dia.	Len.	Class 4g6g
5/6	7/32	11	14	M14x2
7/8	9/32	13	16	M16x2
10	3/8	16	20	M20x2.5
13	1/2	20	24	M24x3
16	5/8	25	30	M30x3.5

Gunnebo Johnson Corporation cannot assume responsibility for:

- (1) Machining quality,
- (2) Application,
- (3) Attachment to power source or load.

• **Never use a worn-out or damaged hook.**

“Each day before being used, the sling and all fastenings and attachments shall be inspected for damage or defects by a competent person designated by the employer. Additional inspections shall be performed during sling use where service conditions warrant. Damaged or defective slings shall be immediately removed from service.” - OSHA 1910.184 (d).

“In addition to the inspection required by paragraph (d) of this section, a thorough periodic inspection of alloy steel chain slings in use shall be made on a regular basis, to be determined on the basis of (A) frequency of sling use; (B) severity of service conditions; (C) nature of lifts being made; and (D) experience gained on the service life of slings used in similar circumstances. Such inspections shall in no event be at intervals greater than once every 12 months.” - OSHA 1910-184 (e) (3) (i).

“The thorough inspection of alloy steel chain slings shall be performed by a competent person designated by the employer, and shall include a thorough inspection for wear, defective welds, deformation and increase in length. Where such defects or deterioration are present, the sling shall be immediately removed from service.” - OSHA 1910.184 (e) (3) (iii).

“Worn or damaged alloy steel chain slings or attachments shall not be used until repaired.” - OSHA 1910.184 (e) (7) (i).

Self-locking hook with wear greater than 10 percent of the original dimension for any cross-section shall be removed from service.

Inspect self-locking hook and threads with magnetic particle and/or dye penetrant at intervals no greater than once annually. Some disassembly may be required.

Self-locking hook with corroded threads shall be removed from service and shall not be returned to service unless approved by a competent person.

Self-locking hook that is broken, cracked, bent, stretched, twisted, or welded on shall be removed from service and shall not be repaired.

Self-locking hook that is nicked, gouged or lapped shall be removed from service and shall not be returned to service unless properly repaired.

Hook latch shall properly close and lock.

Self-locking hook with latch tip opening greater than amount given in TABLE 3A and TABLE 3B shall be removed from service and shall not be returned to service unless properly repaired.

- **Never use a hook in extreme temperatures.**

Alloy steel self-locking hooks shall not be used while heated above 1000°F or cooled below -40°F.

Alloy steel self-locking hooks shall be permanently removed from service if heated above 1000°F.

Working Load Limits (WLL) given in TABLE 1A and 1B are valid between temperature of -40° and 400°F.

WLL shall be reduced in accordance with TABLE 4A & 4B when heated between 400°F and 1000°F.

Permanent WLL reduction shall be made in accordance with TABLE 4A and 4B for self-locking hooks heated over temperatures indicated. Lifting equipment identification tag shall be replaced and the new tag shall have the reduced WLL.

**TABLE 3A**

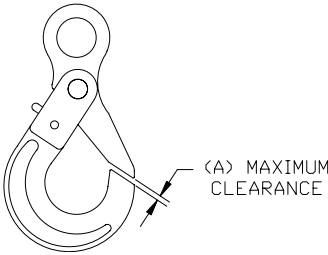

Trade Size		(A) Max. Clearance			
		Material Handling		Personnel Handling	
MM	IN	MM	IN	MM	IN
5/6	7/32	2.2	.09	1.5	.06
7/8	9/32	2.7	.11	1.9	.07
7	9/32	2.7	.11	1.9	.07
8	5/16	2.7	.11	1.9	.07
10	3/8	3.2	.13	2.2	.09
13	1/2	3.7	.15	2.6	.10
16	5/8	4.7	.19	3.2	.13
18/20	3/4	5.3	.21	3.6	.14
22	7/8	6.3	.25	4.2	.17
26	1	6.8	.27	4.6	.18
28	1-1/8	7.7	.30	5.1	.20
32	1-1/4	7.7	.30	5.1	.20

**TABLE 4A GRADE 80**

Hook Component Temperature	Percentage of TABLE 1A WLL	
	During Exposure	After Exposure
-40°F to 400°F	None	None
>400°F to 500°F	95%	None
>500°F to 600°F	90%	None
>600°F to 700°F	82%	None
>700°F to 800°F	75%	90%
>800°F to 900°F	65%	75%
>900°F to 1000°F	60%	70%

**TABLE 3B**

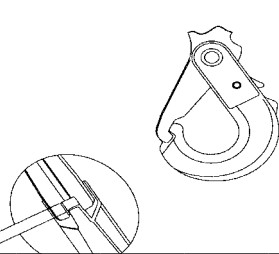

Trade Size		(A) Max. Clearance			
		Material Handling		Personnel Handling	
MM	IN	MM	IN	MM	IN
5/6	7/32	3.2	.13	2.2	.09
7/8	9/32	3.7	.15	2.7	.11
7	9/32	3.7	.15	2.7	.11
8	5/16	3.7	.15	2.7	.11
10	3/8	4.2	.17	3.2	.13
13	1/2	4.7	.19	3.7	.15
16	5/8	5.7	.23	4.7	.19
18/20	3/4	6.3	.25	5.3	.21
22	7/8	7.3	.29	6.3	.25

**TABLE 4B GRADE 100**

Hook Component Temperature	Percentage of TABLE 1B WLL	
	During Exposure	After Exposure
-40°F to 400°F	None	None
>400°F to 500°F	95%	95%
>500°F to 600°F	90%	90%
>600°F to 700°F	82%	85%
>700°F to 800°F	75%	80%
>800°F to 900°F	65%	75%
>900°F to 1000°F	60%	70%

- **Never use a hook in alkaline or acidic conditions.**

Gunnebo Lifting alloy steel BK self-locking hooks shall not be used in alkaline or acidic conditions. Resulting metal embrittlement and accelerated corrosion can cause sudden failure. Hot dipped galvanizing and electro-zinc plating shall be done only by Gunnebo Lifting.

**MAKE SURE  
YOU GET  
THE ORIGINAL.**

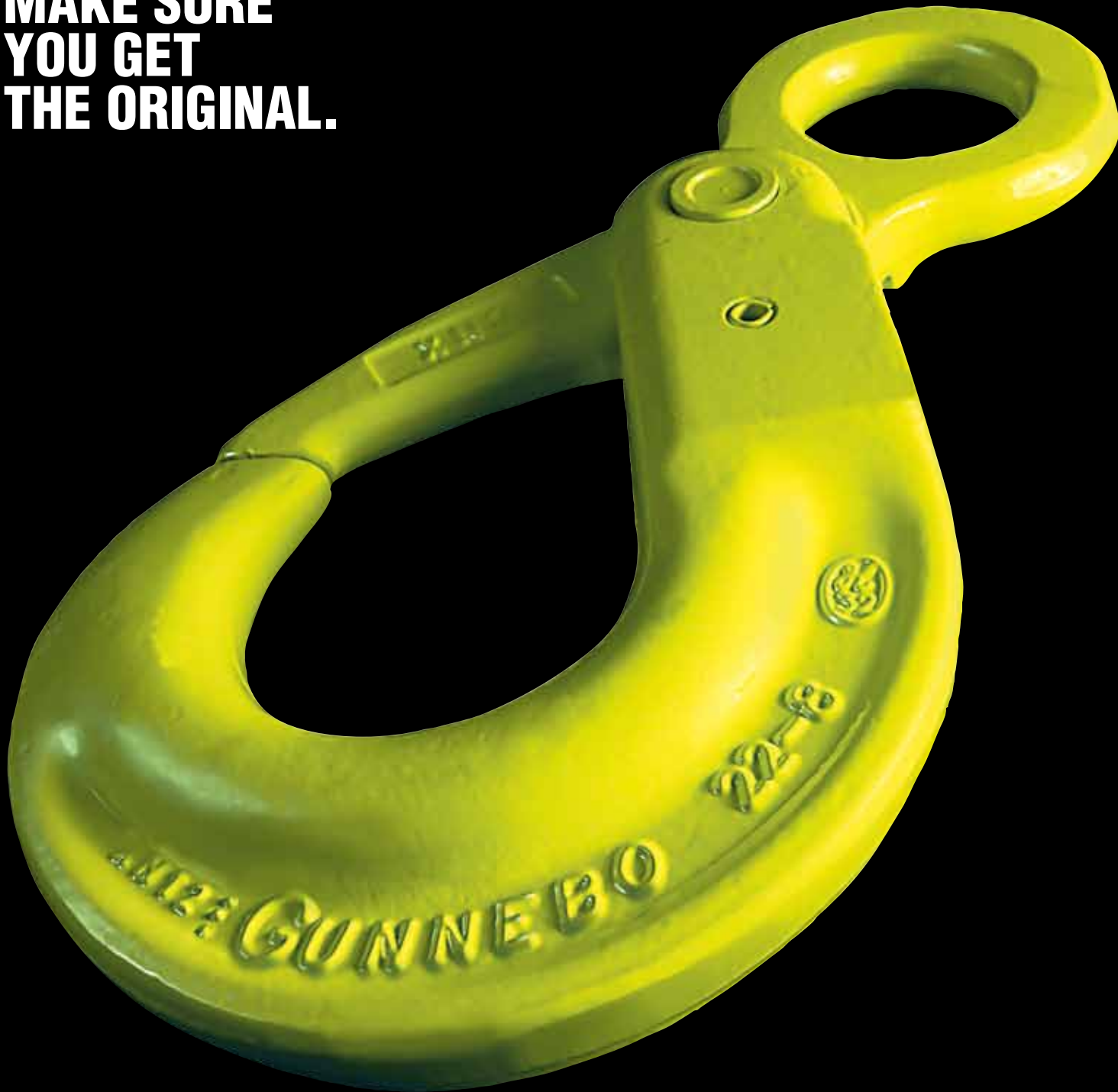

For more than 200 years, satisfied customers have counted on the Gunnebo Lifting name – and the attributes that go with it. Innovation. Durability. Reliability. Quality. Value.

The Gunnebo Lifting name represents a tradition of manufacturing excellence and an unequalled commitment to research, testing, and rigorous safety assurance. The bottom line is: when you specify Gunnebo Lifting chain and components, you get the best you can buy.

Until recently, you could easily identify the renowned Gunnebo Lifting brand of lifting components by the distinctive bright yellow coating. Now other brands have begun to paint their products yellow. However, as one of our customers said: “just because it’s yellow doesn’t mean it’s Gunnebo Lifting.”

For the highest quality chain, hooks, links, and other lifting components, ask for the original. Gunnebo Lifting.

**GUNNEBO JOHNSON**  
CORPORATION

Corporate Office: 1240 North Harvard • Tulsa, OK USA • Toll Free 800-331-5460 • Fax 918-834-0984 • [www.gunnebojohnson.com](http://www.gunnebojohnson.com)



**Gunnebo Johnson Corporation, USA**

Tel: +1 918 832 8933  
E-mail: sales@gjcorp.com  
www.gunnebojohnson.com

**Gunnebo Industries Pty Ltd, AUSTRALIA**

Tel: +61 2 97 565 544  
E-mail: general.info@gunneboindustries.com.au  
www.gunneboliftingibc.com.au

**Gunnebo Industries Ltda, BRAZIL**

Tel: +55 11 4055 9800  
E-mail: gunneboindustries@gunneboindustries.com.br  
www.gunneboliftingibc.com

**Gunnebo Industries Co. LTD, P.R. of CHINA**

(Kunshan)  
Tel: +86 512 5525 2200  
E-mail: info@gunnebolifting.cn  
www.gunneboliftingibc.com

**Gunnebo Industries GmbH, GERMANY**

Tel: +49 273 989 720  
E-mail: info@gunneboindustries.de  
www.gunneboindustries.de

**Gunnebo Industries Ltd, IRELAND**

Tel: +353 1 4584 836  
E-mail: ireland@gunnebolifting.com

**Gunnebo Anja Industrier AS, NORWAY**

Tel: +47 561 933 00  
E-mail: sales@gunneboindustrier.no  
www.gunneboindustrier.no

**Gunnebo Industries Sp.zo.o., POLAND**

Tel: +48 552 422 926  
E-mail: zawiesia@gunneboindustries.pl  
www.gunnebolifting.pl

**Gunnebo Industries (Pty) Ltd, SOUTH AFRICA**

Tel: +27 11 614 6078  
E-mail: info@gunneboindustries.co.za  
www.gunneboliftingibc.com

**Gunnebo Industrier AB, SWEDEN**

Lifting Systems  
Tel: +46 31 76 43 700  
E-mail: gbg@gunnebolifting.com  
www.gunnebolifting.com

**International Sales**

Tel: +46 220 384 00  
E-mail: export@gunnebolifting.com  
www.gunneboindustries.com

**Gunnebo Industries Ltd, UNITED KINGDOM**

Tel: +44 152 752 2560  
E-mail: sales@gunneboindustries.co.uk  
www.gunneboindustries.co.uk

For more information

**8 0 0 3 3 1 - 5 4 6 0**



**GUNNEBO JOHNSON**  
CORPORATION

Copyright © Gunnebo Industries. All rights reserved.