

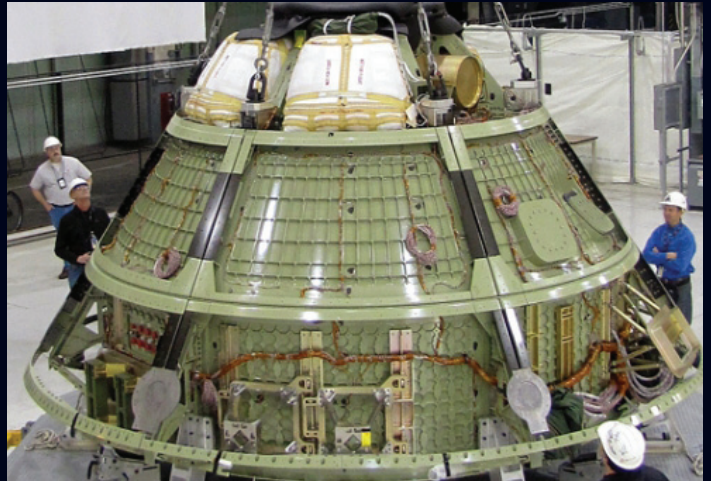

Hoist Rings Mfg.

Valdosta, Georgia



only

SAFETY IS OUR BUSINESS



HEAVY DUTY®



SAFETY ENGINEERED



EZ-TORQUE®



SIDE PULL

WHY ADB®?

ADB® is the originator and industry's leading manufacturer of hoist rings and safety lifting devices used in many sectors of manufacturing and construction. A sample of the many sectors in which hoist rings are used include aerospace and defense, stamping and injection molding, power generation, and manufacturing. Our quality assurance system is certified to ISO 9001:2008 and our record of providing safe products and customized solutions for over 45 years makes ADB® the first choice for hoist rings.

- We are the Original Designer and Manufacturer of Safety Hoist Rings. You are buying from the most experienced hoist ring manufacturer on the planet!
- All our center pull hoist rings conform to the manufacturing and design requirements of ASME B30.26-Rigging Hardware.
- Since 1964, ADB® has been manufacturing hoist rings and lifting devices without a single failure when used in accordance with manufacturer's recommendations.
- We are the Industry Leader and Specialist in Customized lifting devices. With 100% engineering support from quote to final lift, we will tailor our products to fit your unique need/application.
- We perform extensive non-destructive testing on our hoist rings/lifting devices via magnetic particle inspection, liquid penetrant inspection, hardness testing, and mechanical/functionality testing to ensure the safest lifting product.
- We are a NAVSEA-271 Certified Facility, frequently performing specialized NDT testing on our products for government operations/contractors.
- ADB®'s Quality Management System has been registered to ISO 9001 since 2008.
- ADB® can offer our products in a variety of plating options: Electroless Nickel, Cadmium, Ti-Cad, Zinc, Titanium Nitride, etc.



TABLE OF CONTENTS



Heavy Duty[®]
Hoist Rings
Page 12



Heavy Duty[®]
Hoist Rings - Metric
Page 13



Safety Engineered
Hoist Rings
Page 14



Safety Engineered Hoist
Rings - Metric
Page 15



Stainless Steel Safety
Engineered Hoist Rings
Page 16



Stainless Steel Safety
Engineered Hoist Rings - Metric
Page 17



EZ-Torque[®]
Hoist Rings
Page 18



Heavy Duty[®]
Side Pull Hoist Rings
Page 19



Side Pull
Hoist Rings
Page 20



Flip-Flop
Hoist Rings
Page 21



Fast-Lok[®] Plate Lifting
System
Page 22



Weld-In
Threaded Inserts
Page 22



Spin-N-Lok[®]
Hoist Rings
Page 23



Heavy Duty[®] Road Plate
Hoist Ring
Page 23



Heavy Duty[®]
Weld Mount Hoist Rings
Page 24



Scissor-Lok[™]
System
Page 24



Super-Coil
Hoist Rings
Page 25



Heavy Duty[®]
Swivel/Pivot Lift Plate
Page 25



Bolt Type
Anchor Shackle
Page 26



Weldless
Alloy Rings
Page 26



Shackle
Hoist Rings
Page 27



Universal
Lift Ring
Page 28



Windworker[™]
Page 29



SAFETY HOIST RINGS

ADB® Hoist Rings Versus Eyebolts Under Load

Safety Hoist Rings provide maximum safety when lifting heavy loads and are designed to replace conventional lifting hardware and devices that have been outmoded by new standards and regulations. As with all mechanical devices, regular inspection for wear and strict adherence to the manufacturer's recommendations is necessary to prevent failure.

EXCESSIVE SIDE LOADS CAN CAUSE EYE BOLTS TO FAIL

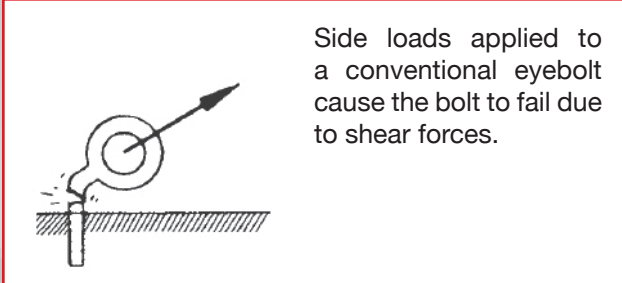

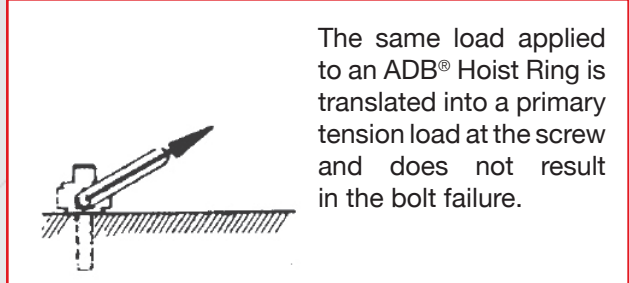

SIDE LOADS ARE WELL WITHIN THE DESIGNED LIMITS OF THE SAFETY HOIST RING



Use Hoist Rings for Added Lifting Safety

Side or angular pulling forces can cause eyebolts to twist, bend or break when heavy, angular, unbalanced loads are involved.

ADB® Hoist Rings vs Eyebolts				
	Thread Size	ADB Heavy Duty Hoist Rings		
		Rated Load Capacity (Lbs)		
		Straight Pull	45 degree lift	90 degree lift
	1/4"-20	550	550	550
	5/16"-18	800	800	800
	3/8"-16	1000	1000	1000
	1/2"-13	2500	2500	2500
	5/8"-11	4000	4000	4000
	3/4"-10	5000	5000	5000
	7/8"-10	8000	8000	8000
1"-8	10000	10000	10000	
1 1/4"-7	15000	15000	15000	
1 1/2"-6	24000	24000	24000	
	Thread Size	Shoulder Eye Bolt		
		Rated Load Capacity (lbs)		
		Straight Pull	45 degree lift	90 degree lift
	1/4"-20	480	144	Not Recommended
	5/16"-18	800	240	Not Recommended
	3/8"-16	1200	360	Not Recommended
	1/2"-13	2200	660	Not Recommended
	5/8"-11	3500	1050	Not Recommended
	3/4"-10	5200	1560	Not Recommended
	7/8"-10	7200	2160	Not Recommended
1"-8	10000	3000	Not Recommended	
1 1/4"-7	15200	4560	Not Recommended	
1 1/2"-6	21400	6420	Not Recommended	

THE STANDARD OF PERFORMANCE

Designed in accordance with the highest safety standards. ADB®'s Safety Hoist Rings provide the kind of safety that protects hoist ring users and material against accidents before they occur. Accidents frequently occur when eyebolts break or lifting hooks disengage. Safety Hoist Rings will not yield to heavy side loads within their rated capacity. Unlike eyebolts, the Hoist Ring pivots 180° and swivels 360° to compensate for pitch, roll and sway when lifting heavy unbalanced loads.

Replaces conventional eyebolts for maximum lift safety in a wide variety of applications

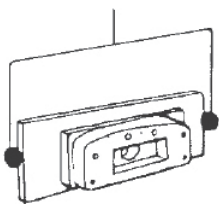

Large Dies and Fixtures

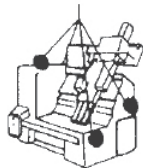

Heavy Machinery

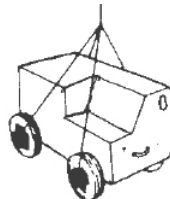

Mobile Equipment

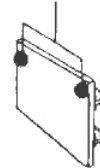

Structural Handling

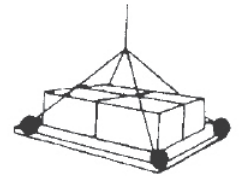

Cargo Handling



PLATING OPTIONS

ADB® recommends that you select the plating option that is best suited for your specific application. Please contact our engineering department for further information including plating options not listed.



Electroless Nickel



Black Oxide
(comes standard)

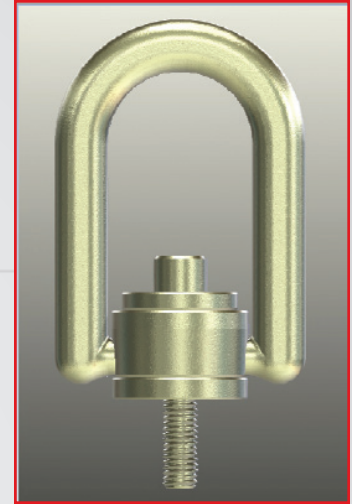

Cadmium

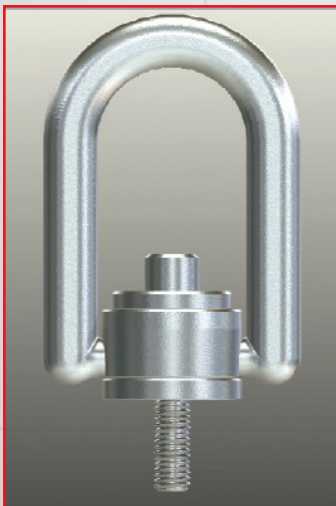

Clear (Blue) Zinc



**Yellow Zinc
Chromate**

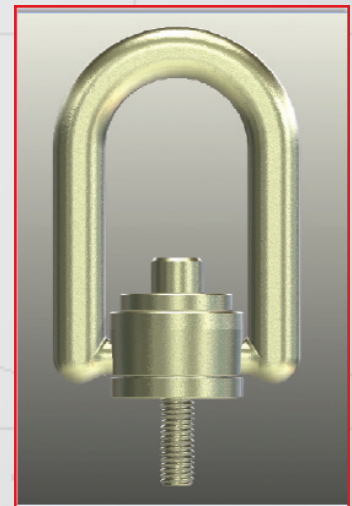

Titanium-Cadmium
(Ti-Cad)

HEAVY DUTY® SAFETY HOIST RINGS

DO NOT BE FOOLED!

Heavy Duty® Safety Hoist Rings has set the new standard for safety lifting products. Made from forged high strength alloy steel, the one piece body and shouldered d-ring eliminates shoulder pins. ADB®'s Heavy Duty® Hoist Ring has 6 assembly parts versus 10 parts on other lifting devices and fewer components means savings and added safety for hoist ring users.

Heavy Duty® Hoist Rings are stronger than competitive lifting devices. They provide better value at lower cost while providing the quality and safety expected from the leader in safety lifting products.

All ADB® products are subjected to critical non-destructive testing. Users can trust in the reliability and safety of the "Only" Heavy Duty® Hoist Ring.



SAFETY ENGINEERED HOIST RINGS

DO NOT BE FOOLED!

Competitive products are assembled by drilling a hole through the shoulder pin and securing it to the body with a “roll pin.”

The ADB® Safety Engineered hoist rings are designed with the use of a patented shoulder pin design which allows for rotation if necessary without shearing the retaining dowels. The design also allows for disassembly for inspections AND reassembly. This design distinguishes the ADB® hoist ring from all others.

These processes DO NOT require putting a hole through the shoulder pin, we use grooved shoulder pins secured with a solid retaining dowel. This allows the pin to rotate if necessary without shearing the dowel or clip. ADB® uses only hardened dowel pins for assembly of hoist rings. In competitive products, if the shoulder pin should bind against the u-bar for any reason (accumulation of dirt, rust, improper loading etc.) the shoulder pin installed with a roll pin is likely to shear, allowing the shoulder pin to come out. This is not the case with ADB® hoist rings.

This patented design allows the ADB® hoist ring to be disassembled, tested for compliance with safety standards AND reassembled easily. This is a requirement by some governmental agencies. ADB® provides the EXTRAS you expect, at no added cost to you, from the leader of quality lifting devices.

ADB® & ONLY ADB® CAN OFFER YOU THIS SAFETY ADVANTAGE.

DON'T ACCEPT LOOK ALIKE IMITATIONS!

No other manufacturer can make that statement.

SAFETY ENGINEERED HOIST RINGS: Pivot and swivel to compensate for pitch, roll and sway when lifting heavy, unbalanced loads • Prevent lifting hooks from disengaging • Made of highest quality alloy steel with certified heat treatment • Available in 550, 800, 1,000, 2,500, 4,000, 5,000, 7,000, 8,000, 10,000, 15,000, 24,000, 30,000, 50,000, 75,000, 100,000, 150,000, 200,000, and 250,000 pound working-load capacities (in any direction).

ADB®'s Safety Hoist Rings have been design tested.

Certified Test Reports are available upon request.



WARNING!

General Hoist Ring Safety and Installation Guidelines

Improper use of ADB® lifting devices could result in personal injury, damaged equipment, or death. In order to ensure maximum safety, please read and understand the following ADB® safety guidelines prior to using any ADB® lifting device.

1. **IMPORTANT!!** The force on each hoist ring is not just the total weight divided by the number of hoist rings. The force can be greater at lower lift angles. See example below:
2. Never exceed the rated load capacity (except when proof testing) of the hoist ring. The 5:1 design factor is provided in case of mis-use such as overload or uneven loading.

$$F = \frac{W}{N \sin A}$$

$$A=65^\circ, F = \frac{4000}{4 \sin 65^\circ} = 1103 \text{ lbs.}$$

$$A=14^\circ, F = \frac{4000}{4 \sin 14^\circ} = 4134 \text{ lbs.}$$

F = Force on each hoist ring
 W = Total weight = 4000 lbs.
 N = Number of hoist rings = 4
 A = Lifting angle

3. ADB® recommends the parent material to have an ultimate tensile strength of least 80,000 psi in order to maintain the full load rating. For lower tensile materials, through hole mounting with a bolt and washer on the opposite side is required. If the user cannot achieve these requirements, contact ADB®'s engineering department for other possible options.
4. Do not allow hoist rings to bind and avoid applying side loads to the bail. Ensure that loads applied are in the same direction of the bail. If necessary, use a spreader bar to avoid binding. See below:

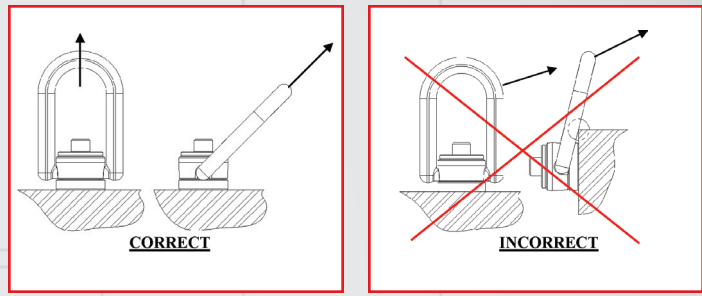

5. The use of free fit spacers should not be used between the hoist ring and the mounting surface. This will reduce the working capacity of the device. See below:

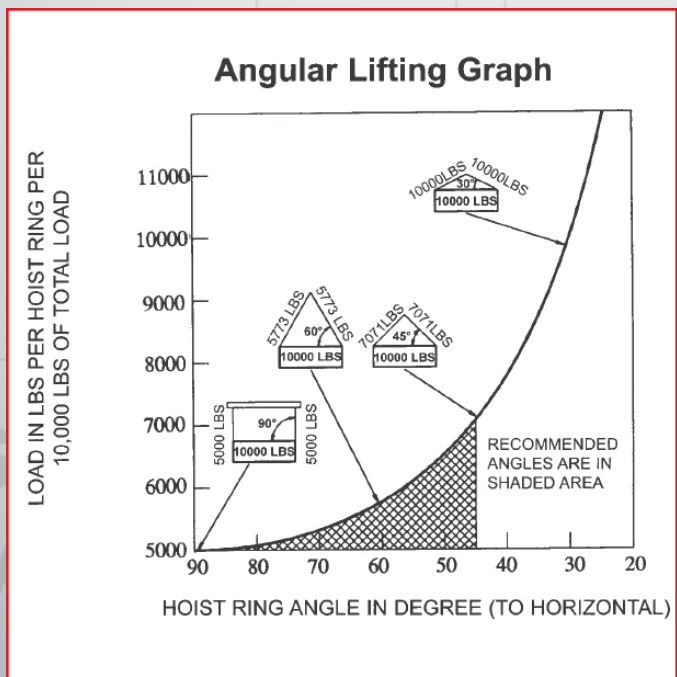
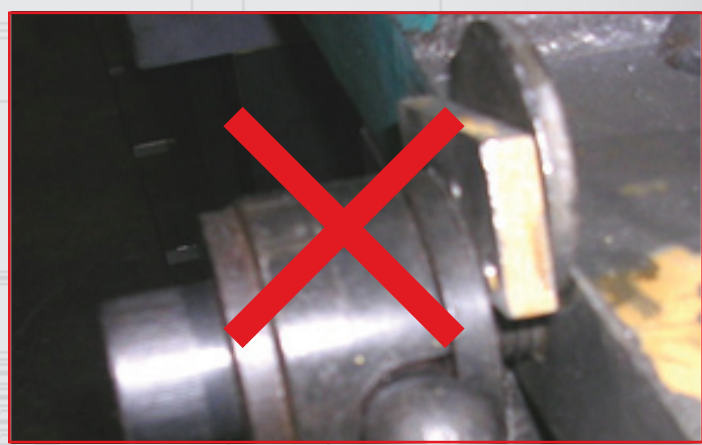

6. Hoist rings should be installed in a manner that allows 360 degrees of rotation and 180 degrees of pivot. Any obstructions within this range will prohibit a safe and proper use of the device. The mounting surface must be flat and smooth for full contact of the device. All ADB® lifting devices are to be installed perpendicular to the surface of the work station. Any lifting device installed at any other angle other than 90 degrees could cause failure to the device and/or damage to the equipment being lifted.



WARNING!

7. Never lift with any device, such as oversized hooks, chains, or cables, that could cause side loading or damage to the bail. See photo to right:

8. Ensure that the mounting screw/stud is tightened to the recommended torque value (see top of washer). All torque values are based on a dry installation without the use of lubricant. If lubricant is used, contact ADB®'s engineering department for revised torque value. For temporary installations or weaker parent material, the torque can be reduced by 50% in order to prevent thread stripping.

9. Apply loads gradually to AVOID SHOCK LOADS.

10. Environment:

A. Temperature - When ADB® Swivel Hoist Rings are to be used at temperatures above 400 degrees F (204 degrees C) or below -20 degrees F (-29 degrees C), please consult ADB®'s engineering department for available options.

B. Chemically Active Environments Caution!! The integrity of ADB® hoist rings can be jeopardized by exposure to chemical, caustic, or acidic substances. Contact ADB®'s engineering department for available options.

Refer to ADB® plating options for the use of hoist rings in chemical, saltwater, or offshore environments, military or aviation operations, or sandy/dry areas

11. Repairs, alterations or modifications to any ADB® lifting device is prohibited unless otherwise specified by ADB®. In the event that the bolt needs to be replaced, use only ADB® certified replacement bolts.

12. Do not reeve slings from one bail to another, as this can decrease the lifting angle and increase the load per hoist ring.

13. Do not allow hoist rings to bind and avoid applying side loads to the bail. Ensure that loads applied are in the same direction of the bail. If necessary, use a spreader bar to avoid.



Safe



Unsafe
Do Not Reeve

WARNING!

Improper maintenance and inspections of ADB® lifting devices could result in damaged equipment, personal injury, or death. In order to ensure maximum safety, please read and understand the following ADB® maintenance and inspection guidelines prior to using any ADB® lifting device.

Maintenance

1. When ADB® hoist rings are not being used, they should be stored in a manner that prevents corrosion or damage from occurring.
2. Do not remove the installation and safety tag from the lifting device.
3. The identification of the lifting device should remain legible and maintained by the user during the life of the device.



Inspection

1. Visually examine the lifting device prior to any lifting operation.
2. The frequency of inspection should depend upon the frequency of use, severity of service conditions, and the criticality of the lift.
3. Removal criteria: ADB®'s lifting device should be removed from service if the following conditions exist:
 - A. Missing Manufacturers identification
 - B. Indications of heat damage
 - C. Excessive corrosion or pitting
 - D. Damaged or missing load bearing components
 - E. Excessive nicks or gouges
 - F. Excessive thread damage
 - G. Evidence of unauthorized welding or modification
 - H. Lack of ability to swivel 360 degrees or pivot 180 degrees
4. If it is suspected that damage has been done to an ADB® lifting device, ADB® offers evaluation services thru magnetic particle testing, tensile testing, and mechanical hardness testing. Call ADB®'s engineering department for more information.

ADB® recommends ADB-Field inspection form to be used for customer inspection programs (available for download @ www.adbhoiststrings.com).

WARNING!

READ PRIOR TO USE AND COMPLY WITH ALL INSTALLATION AND SAFETY NOTES

INSTALLATION NOTES: Tap thread perpendicular to the mounting surface. Mounting surface should be flat to provide 360° flush seating for the hoist ring. For installation in ferrous materials the bolt should be tightened to the full torque load (+0-20%). To maintain the 5:1 design factor of ADB® hoist rings, ADB® recommends the ultimate tensile strength of the mating material to be a minimum of 80,000 psi. For weaker mating material, if possible, consider using longer bolts or through-hole mounting with a nut and washer on the back side. To prevent stripping the mating thread, lower torque value (down to half of value) may be considered, especially in temporary installations. After installation, validate that hoist ring swivels and pivots freely in all directions.

SAFETY NOTES: (1) **NEVER EXCEED WORKING LOAD LIMIT.** (2) Visually inspect hoist ring for damage before each use. (3) Some loosening of the bolt may develop after prolonged service in a permanent installation and it is advisable to periodically retighten to maintain the specified torque value. (4) Apply loads gradually to, **AVOID SHOCK LOADS.** (5) The use of free fit spacers between the bushing flange and the mounting surface is not recommended. (6) **DO NOT USE OVERSIZED HOOKS OR ATTACHMENT METHODS THAT SPREAD THE RING.** (7) **RING MUST BE ALIGNED WITH THE DIRECTION OF THE LOAD (SEE FIG)** (8) Do not attach guidelines to hoist rings. (9) **DO NOT LEAVE GAP BETWEEN BUSHING AND MOUNTING SURFACE (SEE FIG).** Do not interchange ADB® hoist ring components with other manufacturers. (10) **For further information or answers to any questions, consult ADB® Engineering Support at: 1.800.423.4425.**

ADB® CUSTOM ORDERSHEET

Return via email: sales@adbhoiststrings.com
 Return via fax: 229-253-8929
 Contact via phone: 1-800-423-4425

Customer Name:	Customer Contact:	Date:
Customer Phone:	Customer Fax:	Customer Email:
Preferred Distributor Name:	Distributor Phone Number:	
	Distributor Fax:	
ADB® Standard Part Number:	Quantity Requested:	
Additional information, dimensional request, and required certifications:		

<p>Working Load Limit:</p> <div style="border: 1px solid black; height: 80px;"></div>		<p>Special Plating: (Black Oxide is Standard)</p> <div style="border: 1px solid black; height: 80px;"></div>
<p>Proof Load Test Requirement:</p> <div style="border: 1px solid black; height: 80px;"></div>		<p>Extra Nut and Washer for through hole applications:</p> <div style="border: 1px solid black; height: 80px;"></div>
<p>Thread Diameter and TPI or Pitch:</p> <div style="border: 1px solid black; height: 80px;"></div>		<p>Thread Projection:</p> <div style="border: 1px solid black; height: 80px;"></div>

CONVERSION CHART

useful conversion data (approximation)

To Convert	From	To	Multiply By
Length	Millimeter (mm)	Inch (in)	0.03937
Torque	Newton-Meter (Nm)	Foot-Pound (ft-lbs)	0.7376
Weight	Kilogram (kg)	Pound (lb)	2.204

Photocopies of this page are permitted only for the sole purpose of submissions of quote request to ADB® (www.adbhoiststrings.com)



HEAVY DUTY® HOIST RINGS

COMPLETE LINE THROUGH 30,000 POUND WORKING LOAD LIMITS

- Material: Forged High Strength 4140 alloy steel
- Range of movement: Swivel 360°, Pivot 180° Under Load
- Design Factor: Minimum of 5:1
- Meets manufacturing and design requirements of ASME-B30.26 and MIL-STD 209
- Magnetic Particle Inspected Per ASTM 1444
- Black oxide coated
- Each Individually Serial Numbered

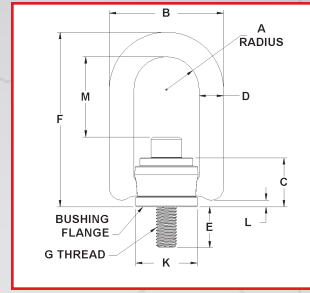

Part No.	Rated Load (lbs)	A	B	C	D	E +/- .12	F	G	K	L	M	TL* (ft-lbs)	Weight (lbs)
33112	550	.65	2.29	.96	.44	.56	3.23	1/4-20	1.25	0.15	1.57	5	.50
33212	800	.65	2.29	.96	.44	.56	3.23	5/16-18	1.25	0.15	1.51	7	.52
33214	800	.65	2.29	.96	.44	1.06	3.23	5/16-18	1.25	0.15	1.51	7	.54
33312	1000	.65	2.29	.96	.44	.56	3.23	3/8-16	1.25	0.15	1.45	12	.56
33314	1000	.65	2.29	.96	.44	1.06	3.23	3/8-16	1.25	0.15	1.45	12	.58
33316	2250	.65	2.29	.96	.44	1.06	3.23	1/2-13	1.25	0.15	1.45	25	.60
33512	2500	1.00	3.50	1.50	.75	.75	5.31	1/2-13	1.89	0.17	2.56	28	1.71
•33513	2500	1.00	3.50	1.50	.75	.75	6.87	1/2-13	1.89	0.17	4.12	28	2.04
33515	2500	1.00	3.50	1.50	.75	1.00	5.31	1/2-13	1.89	0.17	2.56	28	1.72
•33505	2500	1.00	3.50	1.50	.75	1.00	6.87	1/2-13	1.89	0.17	4.12	28	2.05
33516	2500	1.00	3.50	1.50	.75	1.25	5.31	1/2-13	1.89	0.17	2.56	28	1.82
•33517	2500	1.00	3.50	1.50	.75	1.25	6.87	1/2-13	1.89	0.17	4.12	28	2.15
33612	4000	1.00	3.50	1.50	.75	.75	5.31	5/8-11	1.89	0.17	2.44	60	1.76
•33613	4000	1.00	3.50	1.50	.75	.75	6.87	5/8-11	1.89	0.17	4	60	2.09
33614	4000	1.00	3.50	1.50	.75	1.00	5.31	5/8-11	1.89	0.17	2.44	60	1.78
•33604	4000	1.00	3.50	1.50	.75	1.00	6.87	5/8-11	1.89	0.17	4	60	2.11
33615	4000	1.00	3.50	1.50	.75	1.25	5.31	5/8-11	1.89	0.17	2.44	60	1.88
•33616	4000	1.00	3.50	1.50	.75	1.25	6.87	5/8-11	1.89	0.17	4	60	2.21
33714	5000	1.00	3.50	1.50	.75	1.00	5.31	3/4-10	1.89	0.17	2.31	100	1.89
•33715	5000	1.00	3.50	1.50	.75	1.00	6.87	3/4-10	1.89	0.17	3.87	100	2.22
33716	5000	1.00	3.50	1.50	.75	1.50	5.31	3/4-10	1.89	0.17	2.31	100	2.02
•33717	5000	1.00	3.50	1.50	.75	1.50	6.87	3/4-10	1.89	0.17	3.87	100	2.35
33108	7000	1.40	5.10	2.05	1.00	.95	7.37	3/4-10	2.81	0.18	3.57	100	7.20
•33168	7000	1.40	5.10	2.05	1.00	.95	9.00	3/4-10	2.81	0.18	5.20	100	7.93
33102	7000	1.40	5.10	2.05	1.00	1.20	7.37	3/4-10	2.81	0.18	3.57	100	7.23
•33162	7000	1.40	5.10	2.05	1.00	1.20	9.00	3/4-10	2.81	0.18	5.20	100	7.96
33103	7000	1.40	5.10	2.05	1.00	1.45	7.37	3/4-10	2.81	0.18	3.57	100	7.25
•33163	7000	1.40	5.10	2.05	1.00	1.45	9.00	3/4-10	2.81	0.18	5.20	100	7.98
33104	8000	1.40	5.10	2.05	1.00	.95	7.37	7/8-9	2.81	0.18	3.32	160	7.33
•33164	8000	1.40	5.10	2.05	1.00	.95	9.00	7/8-9	2.81	0.18	4.95	160	8.06
33101	8000	1.40	5.10	2.05	1.00	1.20	7.37	7/8-9	2.81	0.18	3.32	160	7.33
•33161	8000	1.40	5.10	2.05	1.00	1.20	9.00	7/8-9	2.81	0.18	4.95	160	8.06
33105	10000	1.40	5.10	2.05	1.00	1.45	7.37	1"-8	2.81	0.18	3.20	230	7.57
•33165	10000	1.40	5.10	2.05	1.00	1.45	9.00	1"-8	2.81	0.18	4.82	230	8.30
33106	10000	1.40	5.10	2.05	1.00	1.20	7.37	1"-8	2.81	0.18	3.20	230	7.63
•33166	10000	1.40	5.10	2.05	1.00	1.20	9.00	1"-8	2.81	0.18	4.82	230	8.36
33107	10000	1.40	5.10	2.05	1.00	2.20	7.37	1"-8	2.81	0.18	3.20	230	7.81
•33167	10000	1.40	5.10	2.05	1.00	2.20	9.00	1"-8	2.81	0.18	4.82	230	8.54
33402	15000	2.00	6.75	2.87	1.25	1.88	9.22	1 1/4"-7	3.88	0.18	3.74	470	15.74
33401	15000	2.00	6.75	2.87	1.25	2.63	9.22	1 1/4"-7	3.88	0.18	3.74	470	16.0
†33420	20000	2.00	6.75	2.87	1.25	2.63	9.22	1 3/8"-6	3.88	0.32	3.62	670	17.2
33424	24000	2.00	6.75	2.87	1.25	2.63	9.22	1 1/2"-6	3.88	0.32	3.49	800	18.1
†33427	30000	2.00	6.75	2.87	1.25	2.96	9.22	2" 4-1/2	3.88	0.32	3.49	1100	22.9
†33432	30000	2.00	6.75	2.87	1.25	2.96	9.22	2"-8	3.88	0.32	3.49	1100	22.9

† Supplied with stud and nut • Long Bar Models * Recommended Torque Load
 For load ranges of 50,000 to 250,000 lbs. refer to our Safety Engineered Hoist Rings.
 Heavy Duty® Hoist Rings are completely interchangeable with Safety Engineered Hoist Rings.



HEAVY DUTY® HOIST RINGS - METRIC

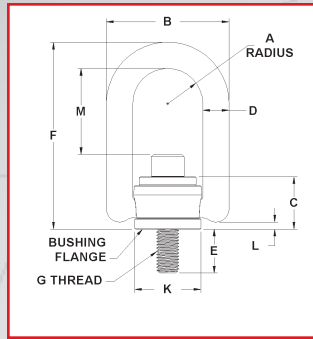

- Material: Forged High strength 4140 alloy steel
- Range of movement: Swivel 360°, Pivot 180° Under Load
- Minimum Design Factor = 5:1
- Meets manufacturing and design requirements of ASME-B30.26 and MIL-STD 209
- Magnetic Particle Inspected Per ASTM 1444
- Black oxide coated
- Each Individually Serial Numbered

Part No.	Rated Load (kg)	A	B	C	D	E +/- 3.0	F	G	K	L	M	TL* (Nm)	Weight (kg)
34212	400	16.5	58.2	24.4	11.1	16	82.0	M8x1.25	31.8	4.0	38.5	9.5	.24
34214	400	16.5	58.2	24.4	11.1	21	82.0	M8x1.25	31.8	4.0	38.5	9.5	.25
34312	450	16.5	58.2	24.4	11.1	16	82.0	M10x1.5	31.8	4.0	36.5	16.0	.25
34314	450	16.5	58.2	24.4	11.1	26	82.0	M10x1.5	31.8	4.0	36.5	16.0	.26
34515	1050	25.4	88.9	38.1	19.1	25	134.9	M12x1.75	48.0	4.4	65.0	37.0	.78
•34505	1050	25.4	88.9	38.1	19.1	25	174.6	M12x1.75	48.0	4.4	104.7	37.0	.93
34516	1050	25.4	88.9	38.1	19.1	32	134.9	M12x1.75	48.0	4.4	65.0	37.0	.83
•34517	1050	25.4	88.9	38.1	19.1	32	174.6	M12x1.75	48.0	4.4	101.7	37.0	.98
34518	1500	25.4	88.9	38.1	19.1	25	135.2	M14x2.0	48.0	4.4	65.3	45.0	.79
•34519	1500	25.4	88.9	38.1	19.1	25	174.9	M14x2.0	48.0	4.4	105.0	45.0	.95
34520	1500	25.4	88.9	38.1	19.1	32	135.2	M14x2.0	48.0	4.4	65.3	45.0	.84
•34521	1500	25.4	88.9	38.1	19.1	32	174.9	M14x2.0	48.0	4.4	105.0	45.0	.98
34614	1900	25.4	88.9	38.1	19.1	25	134.9	M16x2.0	48.0	4.4	62.0	80.0	.81
•34604	1900	25.4	88.9	38.1	19.1	25	174.6	M16x2.0	48.0	4.4	101.7	80.0	.96
34615	1900	25.4	88.9	38.1	19.1	32	134.9	M16x2.0	48.0	4.4	62.0	80.0	.85
•34616	1900	25.4	88.9	38.1	19.1	32	174.6	M16x2.0	48.0	4.4	101.7	80.0	1.00
34714	2200	25.4	88.9	38.1	19.1	25	134.9	M20x2.5	48.0	4.4	58.7	135.0	.86
•34715	2200	25.4	88.9	38.1	19.1	25	174.6	M20x2.5	48.0	4.4	98.4	135.0	1.01
34716	2200	25.4	88.9	38.1	19.1	38	134.9	M20x2.5	48.0	4.4	58.7	135.0	.92
•34717	2200	25.4	88.9	38.1	19.1	38	174.6	M20x2.5	48.0	4.4	98.4	135.0	1.07
34101	3000	35.6	129.5	52.1	25.4	28	187.2	M20x2.5	71.4	4.6	89.7	135.0	3.14
•34161	3000	35.6	129.5	52.1	25.4	28	228.6	M20x2.5	71.4	4.6	131.1	135.0	3.47
34102	4200	35.6	129.5	52.1	25.4	28	187.2	M24x3.0	71.4	4.6	85.7	311.0	3.29
•34162	4200	35.6	129.5	52.1	25.4	28	228.6	M24x3.0	71.4	4.6	127.1	311.0	3.62
34103	4200	35.6	129.5	52.1	25.4	38	187.2	M24x3.0	71.4	4.6	85.7	311.0	3.30
•34163	4200	35.6	129.5	52.1	25.4	38	228.6	M24x3.0	71.4	4.6	127.1	311.0	3.63
34105	4500	35.6	129.5	52.1	25.4	38	187.2	M30x3.5	71.4	4.6	79.7	311.0	3.44
•34165	4500	35.6	129.5	52.1	25.4	38	228.6	M30x3.5	71.4	4.6	79.7	311.0	3.55
34107	4500	35.6	129.5	52.1	25.4	48	187.2	M30x3.5	71.4	4.6	79.7	311.0	3.55
•34167	4500	35.6	129.5	52.1	25.4	48	228.6	M30x3.5	71.4	4.6	121.1	311.0	3.88
34401	7000	50.8	171.5	72.9	31.8	67	234.2	M30x3.5	98.5	8.2	95.0	637.2	7.26
34402	11000	50.8	171.5	72.9	31.8	67	234.2	M36x4.0	98.5	8.2	88.6	1085.5	8.21
†34403	12500	50.8	171.5	72.9	31.8	80	234.2	M42x4.5	98.5	8.2	88.6	1085.5	10.14
†34404	13500	50.8	171.5	72.9	31.8	80	234.2	M48x5.0	98.5	8.2	88.6	1085.5	10.59
†34406	13500	50.8	171.5	72.9	31.8	88	234.2	M56x5.5	98.5	8.2	88.6	1085.5	11.03

† Supplied with stud and nut

• Long Bar Models. Replacement screws are available.



SAFETY ENGINEERED HOIST RINGS

- Material: High strength 4140 alloy steel
- Range of movement: Swivel 360°, Pivot 180° Under Load
- Design Factor: Minimum of 5:1
- Meets manufacturing and design requirements of ASME-B30.26 and MIL-STD 209
- Magnetic Particle Inspected Per ASTM 1444
- Black oxide coated
- Each Individually Serial Numbered

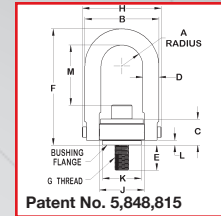

Part No.	Rated Load (lbs)	A	B	C	D	E +/- .12	F	G	H	J	K	L	M	TL* (lbs-ft)	Weight (lbs)
23050	550	.43	1.61	.71	3/8	.54	2.67	1/4-20	1.84	1.00	.75	.17	1.33	5	5 oz.
23051	800	.43	1.61	.71	3/8	.29	2.67	5/16-18	1.84	1.00	.75	.17	1.27	7	5 oz.
23052	800	.43	1.61	.71	3/8	.54	2.67	5/16-18	1.84	1.00	.75	.17	1.27	7	5 oz.
23053	1000	.43	1.61	.71	3/8	.54	2.67	3/8-16	1.84	1.00	.75	.17	1.21	12	5 oz.
23301	2500	.70	2.40	.93	1/2	1.07	3.77	1/2-13	2.58	1.49	1.25	.20	1.84	28	1 lb
23004	2500	.88	3.25	1.22	3/4	.78	4.78	1/2-13	3.52	1.99	1.50	.16	2.31	28	2 lb. 5 oz
•23322	2500	.88	3.25	1.22	3/4	.78	6.72	1/2-13	3.52	1.99	1.50	.16	4.25	28	2 lb. 12 oz
23005	2500	.88	3.25	1.22	3/4	1.03	4.78	1/2-13	3.52	1.99	1.50	.16	2.31	28	2 lb. 5 oz
•23323	2500	.88	3.25	1.22	3/4	1.03	6.72	1/2-13	3.52	1.99	1.50	.16	4.25	28	2 lb
23006	2500	.88	3.25	1.22	3/4	1.28	4.78	1/2-13	3.52	1.99	1.50	.16	2.31	28	2 lb. 5 oz
•23324	2500	.88	3.25	1.22	3/4	1.28	6.72	1/2-13	3.52	1.99	1.50	.16	4.25	28	2 lb. 12 oz
23001	4000	.88	3.25	1.22	3/4	.78	4.78	5/8-11	3.52	1.99	1.50	.16	2.18	60	2 lb. 7 oz
•23319	4000	.88	3.25	1.22	3/4	.78	6.72	5/8-11	3.52	1.99	1.50	.16	4.12	60	2 lb. 12 oz
23002	4000	.88	3.25	1.22	3/4	1.03	4.38	5/8-11	3.52	1.99	1.50	.16	2.18	60	2 lb. 7 oz
•23320	4000	.88	3.25	1.22	3/4	1.03	6.72	5/8-11	3.52	1.99	1.50	.16	4.12	60	2 lb. 14 oz
23003	4000	.88	3.25	1.22	3/4	1.28	4.38	5/8-11	3.52	1.99	1.50	.16	2.18	60	2 lb. 9 oz
•23321	4000	.88	3.25	1.22	3/4	1.28	6.72	5/8-11	3.52	1.99	1.50	.16	4.12	60	3 lb
23007	5000	.88	3.25	1.22	3/4	1.03	4.78	3/4-10	3.52	1.99	1.50	.16	2.06	100	2 lb. 9 oz
•23325	5000	.88	3.25	1.22	3/4	1.03	6.72	3/4-10	3.52	1.99	1.50	.16	4.00	100	3 lb
23008	5000	.88	3.25	1.22	3/4	1.28	4.78	3/4-10	3.52	1.99	1.50	.16	2.06	100	2 lb. 8 oz
23326	5000	.88	3.25	1.22	3/4	1.28	6.72	3/4-10	3.52	1.99	1.50	.16	4.00	100	3 lb. 1 oz
23009	5000	.88	3.25	1.22	3/4	1.53	4.78	3/4-10	3.52	1.99	1.50	.16	2.06	100	6 lb. 10 oz
•23327	5000	.88	3.25	1.22	3/4	1.53	6.72	3/4-10	3.52	1.99	1.50	.16	4.00	100	7 lb. 4 oz
23102	7000	1.40	4.80	1.71	1"	1.04	6.52	3/4-10	5.14	3.00	2.37	.24	3.06	100	6 lb. 10 oz
•23329	7000	1.40	4.80	1.71	1"	1.04	8.11	3/4-10	5.14	3.00	2.37	.24	4.65	100	6 lb. 10 oz
23103	7000	1.40	4.80	1.71	1"	1.54	6.52	3/4-10	5.14	3.00	2.37	.24	3.06	100	6 lb. 12 oz
•23330	7000	1.40	4.80	1.71	1"	1.54	8.11	3/4-10	5.14	3.00	2.37	.24	4.65	100	6 lb. 12 oz
23101	8000	1.40	4.80	1.71	1"	1.04	6.52	7/8-9	5.14	3.00	2.37	.24	2.93	160	7 lb
•23328	8000	1.40	4.80	1.71	1"	1.04	8.11	7/8-9	5.14	3.00	2.37	.24	4.52	160	7 lb
23105	10000	1.40	4.80	1.71	1"	1.29	6.52	1"-8	5.14	3.00	2.37	.24	2.81	230	7 lb
•23331	10000	1.40	4.80	1.71	1"	1.29	8.11	1"-8	5.14	3.00	2.37	.24	4.40	230	7 lb
23106	10000	1.40	4.80	1.71	1"	1.54	6.52	1"-8	5.14	3.00	2.37	.24	2.81	230	7 lb
•23332	10000	1.40	4.80	1.71	1"	1.54	8.11	1"-8	5.14	3.00	2.37	.24	4.40	230	7 lb
23107	10000	1.40	4.80	1.71	1"	2.29	6.52	1"-8	5.14	3.00	2.37	.24	2.81	230	7 lb
•23333	10000	1.40	4.80	1.71	1"	2.29	8.11	1"-8	5.14	3.00	2.37	.24	4.40	230	7 lb
23108	10000	1.40	4.80	1.71	1"	2.29	6.52	1-1/8"-8	5.14	3.00	2.37	.24	2.81	230	7 lb
23402	15000	1.75	6.00	2.11	1-1/4	1.89	8.73	1-1/4"-8	6.50	3.76	3.2	.35	4.12	470	14 lb
23401	15000	1.75	6.00	2.11	1-1/4	1.89	8.73	1-1/4"-7	6.50	3.76	3.20	.35	4.12	470	14 lb
†23204	24000	2.25	8.00	2.81	1-3/4	2.70	12.47	1-1/2"-8	8.55	4.87	4.20	.47	6.41	800	33 lb. 12 oz
23202	24000	2.25	8.00	2.81	1-3/4	2.70	12.47	1-1/2"-6	8.55	4.87	4.20	.47	6.41	800	33 lb. 12 oz
†23203	30000	2.25	8.00	2.81	1-3/4	2.96	12.47	2"-8	8.55	4.87	4.20	.47	6.41	1100	36 lb
†23200	30000	2.25	8.00	2.81	1-3/4	2.96	12.47	2"-4-1/2	8.55	4.87	4.20	.47	6.41	1100	36 lb
23201	30000	2.25	8.00	2.81	1-3/4	2.96	12.47	2"-4-1/2	8.55	4.87	4.20	.47	6.41	1100	36 lb
†23501	50000	3.00	10.50	4.09	2-1/4	4.00	16.87	2-1/2"-8	11.67	6.52	5.75	1.12	8.03	2100	87 lb. 8 oz
†23503	50000	3.00	10.50	4.09	2-1/4	4.00	16.87	2-1/2"-4	11.67	6.52	5.75	1.12	8.03	2100	87 lb. 8 oz
†23600	75000	3.75	13.00	5.27	2-3/4	5.20	19.50	3"-4	14.15	8.10	7.25	1.00	8.48	4300	166 lb
†23701	100000	4.00	14.50	6.06	3-1/4	7.00	22.09	3-1/2"-4	15.90	8.60	7.25	1.09	9.28	6600	240 lb
†23751	150000	5.00	18.00	7.50	4.00	8.50	27.38	4-1/4"-4	19.69	10.75	9.87	1.33	12.13	12000	525 lb
†23760	200000	6.00	22.00	9.00	5.00	9.00	33.00	5"-4	24.00	13.00	12.38	1.88	14.50	19800	760 lb
†23770	250000	6.00	22.00	9.00	5.00	9.00	33.00	6"-4	24.00	13.00	12.38	1.88	14.00	29000	841 lb



For higher working load limits, see EZ-Torque Hoist Rings.
 † Supplied with stud and nut • Long Bar Models * Recommended Torque Load

SAFETY ENGINEERED HOIST RINGS METRIC



- Material: High strength 4140 alloy steel
- Range of movement: Swivel 360°, Pivot 180° Under Load
- Design Factor: Minimum of 5:1
- Meets manufacturing and design requirements of ASME-B30.26 and MIL-STD 209
- Magnetic Particle Inspected Per ASTM 1444
- Black oxide coated
- Each Individually Serial Numbered

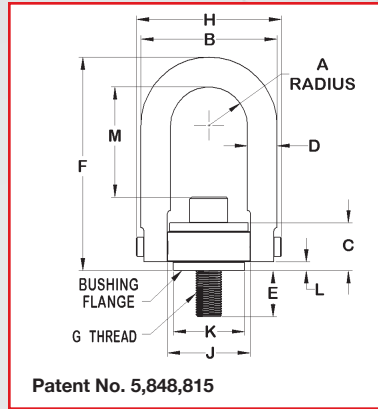

Part No.	Rated Load (kg)	A	B	C	D	E +/- 3.0	F	G	H	J	K	L	M	TL* (Nm)	Weight (kg)
24008	400	10.9	40.9	18.0	9.5	17	67.8	M8 x 1.25	46.7	25.4	19.1	4.3	32.1	9.5	0.14
24010	450	10.9	40.9	18.0	9.5	17	67.8	M10 x 1.5	46.7	25.4	19.1	4.3	30.2	16.0	0.14
24012	1050	22.4	82.5	31.0	19.0	19	121.4	M12 x 1.75	89.4	50.5	38.0	4.1	59.4	37.0	1.05
•24014	1050	22.4	82.5	31.0	19.0	19	170.6	M12 x 1.75	89.4	50.5	38.0	4.1	108.6	37.0	1.27
24016	1900	22.4	82.5	31.0	19.0	24	121.4	M16 x 2.0	89.4	50.5	38.0	4.1	55.4	80.0	1.11
•24018	1900	22.4	82.5	31.0	19.0	24	170.6	M16 x 2.0	89.4	50.5	38.0	4.1	104.6	80.0	1.33
24020	2200	22.4	82.5	31.0	19.0	30	121.4	M20 x 2.5	89.4	50.5	38.0	4.1	51.4	135.0	1.16
•24021	2200	22.4	82.5	31.0	19.0	30	170.6	M20 x 2.5	89.4	50.5	38.0	4.1	100.6	135.0	1.38
24022	3000	35.6	121.2	43.4	25.4	29	165.8	M20 x 2.5	130.5	76.2	58.7	6.1	77.0	135.0	3.06
•24023	3000	35.6	121.2	43.4	25.4	29	206.7	M20 x 2.5	130.5	76.2	58.7	6.1	117.9	135.0	3.77
24024	4200	35.6	121.2	43.4	25.4	34	165.8	M24 x 3.0	130.5	76.2	58.7	6.1	73.0	311.0	3.18
•24026	4200	35.6	121.2	43.4	25.4	34	206.7	M24 x 3.0	130.5	76.2	58.7	6.1	113.9	311.0	3.89
24030	4500	35.6	121.2	43.4	25.4	54	165.8	M30 x 3.5	130.5	76.2	58.7	6.1	67.0	311.0	3.30
•24032	4500	35.6	121.2	43.4	25.4	54	206.7	M30 x 3.5	130.5	76.2	58.7	6.1	109.9	311.0	4.01
24040	7000	44.5	152.4	53.6	31.8	46	221.7	M30 x 3.5	165.1	95.5	81.3	8.9	106.3	637.2	6.36
24042	7000	44.5	152.4	53.6	31.8	66	221.7	M30 x 3.5	165.1	95.5	81.3	8.9	106.3	637.2	6.70
24050	11000	57.2	203.2	71.4	44.5	69	316.7	M36 x 4.0	217.2	123.7	106.7	11.9	164.8	1085.5	15.34
†24052	12500	57.2	203.2	71.4	44.5	79	316.7	M42 x 4.5	217.2	123.7	106.7	11.9	158.8	1085.5	15.91
†24054	13500	57.2	203.2	71.4	44.5	79	316.7	M48 x 5.0	217.2	123.7	106.7	11.9	152.8	1085.5	16.36
†24060	22000	76.2	266.7	104.0	57.2	102	428.5	M64 x 6.0	296.4	165.6	146.1	28.4	203.3	2847.5	39.77
†24062	31500	95.25	330.2	133.9	69.85	132	495.3	M72 x 6.0	368.3	205.74	184.15	25.4	215.39	5670	75.45
†24064	51000	101.60	368.3	153.9	82.55	178	561.09	M90 x 6.0	403.86	218.44	196.85	27.69	235.71	9560	109.09

† Supplied with stud and nut

* Recommended Torque Load

NOTE: DIMENSIONS ARE IN MILLIMETERS

SAFETY ENGINEERED HOIST RINGS

STAINLESS STEEL

- Material: 300 Series Stainless Steel
- Design Factor: 5:1
- Range of Movement: Swivel 360°, Pivot 180° Under Load
- NDT: Liquid Penetrant Tested Per ASTM-E 1417
- Purification Process: Clean & Passivate Per ASTM-A967
- Typical Applications: Use Stainless for Corrosive, Cryogenic or Elevated Temperature Environments.
- All dimensions approximate - variations do not affect use or design factor
- Each Individually Serial Numbered

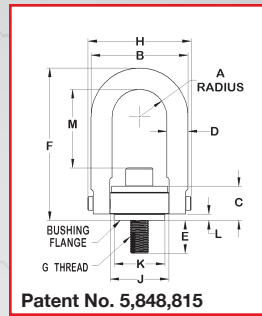

Part No.	Rated Load (lbs)	A	B	C	D	E +/- .12	F	G	H	J	K	L	M	TL* (lbs-ft)	Weight (lbs)
29050	275	.43	1.61	.71	3/8	.54	2.67	1/4-20	1.84	1.00	.75	.17	1.33	2.5	5 oz.
29051	400	.43	1.61	.71	3/8	.29	2.67	5/16-18	1.84	1.00	.75	.17	1.27	3.5	5 oz.
29052	400	.43	1.61	.71	3/8	.54	2.67	5/16-18	1.84	1.00	.75	.17	1.27	3.5	5 oz.
29053	500	.43	1.61	.71	3/8	.54	2.67	3/8-16	1.84	1.00	.75	.17	1.21	6	5 oz.
29301	1250	.70	2.40	.93	1/2	1.07	3.77	1/2-13	2.58	1.49	1.25	.20	1.84	14	1 lb
29004	1250	.88	3.25	1.22	3/4	.78	4.78	1/2-13	3.52	1.99	1.50	.16	2.31	14	2 lb. 5 oz
•29322	1250	.88	3.25	1.22	3/4	.78	6.72	1/2-13	3.52	1.99	1.50	.16	4.25	14	2 lb. 12 oz
29005	1250	.88	3.25	1.22	3/4	1.03	4.78	1/2-13	3.52	1.99	1.50	.16	2.31	14	2 lb. 5 oz
•29323	1250	.88	3.25	1.22	3/4	1.03	6.72	1/2-13	3.52	1.99	1.50	.16	4.25	14	2 lb
29006	1250	.88	3.25	1.22	3/4	1.28	4.78	1/2-13	3.52	1.99	1.50	.16	2.31	14	2 lb. 5 oz
•29324	1250	.88	3.25	1.22	3/4	1.28	6.72	1/2-13	3.52	1.99	1.50	.16	4.25	14	2 lb. 12 oz
29001	2000	.88	3.25	1.22	3/4	.78	4.78	5/8-11	3.52	1.99	1.50	.16	2.18	30	2 lb. 7 oz
29002	2000	.88	3.25	1.22	3/4	1.03	4.78	5/8-11	3.52	1.99	1.50	.16	2.18	30	2 lb. 7 oz
•29320	2000	.88	3.25	1.22	3/4	1.03	6.72	5/8-11	3.52	1.99	1.50	.16	4.12	30	2 lb. 14 oz
29003	2000	.88	3.25	1.22	3/4	1.28	4.78	5/8-11	3.52	1.99	1.50	.16	2.18	30	2 lb. 7 oz
•29321	2000	.88	3.25	1.22	3/4	1.28	6.72	5/8-11	3.52	1.99	1.50	.16	4.12	30	2 lb. 14 oz
29007	2500	.88	3.25	1.22	3/4	1.03	4.78	3/4-10	3.52	1.99	1.50	.16	2.06	50	2 lb. 9 oz
•29325	2500	.88	3.25	1.22	3/4	1.03	6.72	3/4-10	3.52	1.99	1.50	.16	4.00	50	3 lb
29009	2500	.88	3.25	1.22	3/4	1.53	4.78	3/4-10	3.52	1.99	1.50	.16	2.06	50	2 lb. 9 oz
•29327	2500	.88	3.25	1.22	3/4	1.53	6.72	3/4-10	3.52	1.99	1.50	.16	4.00	50	3 lb
29102	3500	1.40	4.80	1.71	1"	1.04	6.52	3/4-10	5.14	3.00	2.37	.24	3.06	50	6 lb. 10 oz
•29329	3500	1.40	4.80	1.71	1"	1.04	8.11	3/4-10	5.14	3.00	2.37	.24	4.65	50	7 lb. 4 oz
29103	3500	1.40	4.80	1.71	1"	1.54	6.52	3/4-10	5.14	3.00	2.37	.24	3.06	50	6 lb. 10 oz
•29330	3500	1.40	4.80	1.71	1"	1.54	8.11	3/4-10	5.14	3.00	2.37	.24	4.65	50	6 lb. 10 oz
29101	4000	1.40	4.80	1.71	1"	1.04	6.52	7/8-9	5.14	3.00	2.37	.24	2.93	80	6 lb. 12 oz
•29328	4000	1.40	4.80	1.71	1"	1.04	8.11	7/8-9	5.14	3.00	2.37	.24	4.52	80	6 lb. 12 oz
29105	5000	1.40	4.80	1.71	1"	1.29	6.52	1"-8	5.14	3.00	2.37	.24	2.81	115	7 lb
•29331	5000	1.40	4.80	1.71	1"	1.29	8.11	1"-8	5.14	3.00	2.37	.24	4.40	115	7 lb
29106	5000	1.40	4.80	1.71	1"	1.54	6.52	1"-8	5.14	3.00	2.37	.24	2.81	115	7 lb
•29332	5000	1.40	4.80	1.71	1"	1.54	8.11	1"-8	5.14	3.00	2.37	.24	4.40	115	7 lb
29107	5000	1.40	4.80	1.71	1"	2.29	6.52	1"-8	5.14	3.00	2.37	.24	2.81	115	7 lb
•29333	5000	1.40	4.80	1.71	1"	2.29	8.11	1"-8	5.14	3.00	2.37	.24	4.40	115	7 lb
29401	7500	1.75	6.00	2.11	1-1/4	1.89	8.73	1-1/4"-7	6.50	3.76	3.20	.35	4.12	235	14 lb
29202	12000	2.25	8.00	2.81	1-3/4	2.70	12.47	1-1/2"-6	8.55	4.87	4.20	.47	6.41	400	33 lb. 12 oz
†29200	15000	2.25	8.00	2.81	1-3/4	2.96	12.47	2"-4-1/2	8.55	4.87	4.20	.47	5.41	400	36 lb
†29501	25000	3.00	10.50	4.09	2-1/4	4.00	16.87	2-1/2"-8	11.67	6.52	5.75	1.12	8.03	1050	87 lb. 8 oz
†29503	25000	3.00	10.50	4.09	2-1/4	4.00	16.87	2-1/2"-4	11.67	6.52	5.75	1.12	8.03	1050	87 lb. 8 oz
†29600	37500	3.75	13.00	5.27	2-3/4	5.20	19.50	3"-4	14.15	8.10	7.25	1.00	8.48	2150	166 lb
†29701	50000	4.00	14.50	6.06	3-1/4	7.00	22.09	3-1/2"-4	15.90	8.60	7.75	1.09	9.28	3300	240 lb

† Supplied with stud and nut

* Recommended Torque Load



SAFETY ENGINEERED HOIST RINGS STAINLESS STEEL/METRIC



- Hoist Ring Material: 300 Series Stainless Steel
- Design Factor: 5:1
- Range of Movement: Swivel 360°, Pivot 180° Under Load
- NDT: Liquid Penetrant Tested Per ASTM-E 1417
- Purification Process: Clean & Passivate Per ASTM-A967
- Typical Applications: Use Stainless for Corrosive, Cryogenic or Elevated Temperature Environments
- Each Individually Serial Numbered

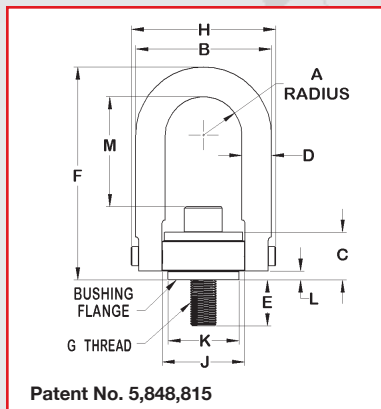

Part No.	Rated Load (kg)	A	B	C	D	E +/- 3.0	F	G	H	J	K	L	M	TL* (Nm)	Weight (kg)
29808	200	10.9	40.9	18.0	9.5	17	67.8	M8 x 1.25	46.7	25.4	19.1	4.3	32.1	4.75	0.14
29810	225	10.9	40.9	18.0	9.5	17	67.8	M10 x 1.5	46.7	25.4	19.1	4.3	30.2	8.0	0.14
29812	525	22.4	82.5	31.0	19.0	19	121.4	M12 x 1.75	89.4	50.5	38.0	4.1	59.4	18.5	1.05
•29814	525	22.4	82.5	31.0	19.0	19	170.6	M12 x 1.75	89.4	50.5	38.0	4.1	108.6	18.5	1.27
29816	950	22.4	82.5	31.0	19.0	24	121.4	M16 x 2.0	89.4	50.5	38.0	4.1	55.4	40.0	1.11
•29818	950	22.4	82.5	31.0	19.0	24	170.6	M16 x 2.0	89.4	50.5	38.0	4.1	104.4	40.0	1.33
29820	1100	22.4	82.5	31.0	19.0	30	121.4	M20 x 2.5	89.4	50.5	38.0	4.1	51.4	67.5	1.16
•29821	1100	22.4	82.5	31.0	19.0	30	170.6	M20 x 2.5	89.4	50.5	38.0	4.1	100.6	67.5	1.38
29822	1500	35.6	121.2	43.4	25.4	29	165.8	M20 x 2.5	130.5	76.2	58.7	6.1	77.0	67.5	3.06
•29823	1500	35.6	121.2	43.4	25.4	29	206.7	M20 x 2.5	130.5	76.2	58.7	6.1	117.9	67.5	3.77
29824	2100	35.6	121.2	43.4	25.4	34	165.8	M24 x 3.0	130.5	76.2	58.7	6.1	73.0	155.5	3.18
•29826	2100	35.6	121.2	43.4	25.4	34	206.7	M24 x 3.0	130.5	76.2	58.7	6.1	113.9	155.5	3.89
29830	2250	35.6	121.2	43.4	25.4	54	165.8	M30 x 3.5	130.5	76.2	58.7	6.1	67.0	155.5	3.30
•29832	2250	35.6	121.2	43.4	25.4	54	206.7	M30 x 3.5	130.5	76.2	58.7	6.1	109.9	155.5	4.01
29840	3500	44.5	152.4	53.6	31.8	46	221.7	M30 x 3.5	165.1	95.5	81.3	8.9	106.3	318.6	6.36
†29842	3500	44.5	152.4	53.6	31.8	66	221.7	M30 x 3.5	165.1	95.5	81.3	8.9	106.3	318.6	6.70
†29850	5500	57.2	203.2	71.4	44.5	69	316.7	M36 x 4.0	217.2	123.7	106.7	11.9	164.8	542.7	15.34
†29852	6250	57.2	203.2	71.4	44.5	79	316.7	M42 x 4.5	217.2	123.7	106.7	11.9	158.8	542.7	15.91
†29854	7250	57.2	203.2	71.4	44.5	79	316.7	M48 x 5.0	217.2	123.7	106.7	11.9	152.8	542.7	16.36
†29860	11000	76.2	266.7	104.0	57.2	102	428.5	M64 x 6.0	296.4	165.6	146.1	28.4	203.3	1423.7	39.77

† Supplied with stud and nut

* Recommended Torque Load

• Long Bar Models

NOTE: DIMENSIONS ARE IN MILLIMETERS



EZ-TORQUE® HOIST RINGS

Exclusively from ADB®, the world's largest manufacturer of Safety Hoist Rings

ADB®, the originator and leader in safety hoist rings, introduces another time and money saving innovation.

ADB®'s EZ-Torque® Hoist Ring eliminates the need of locating and using expensive hydraulic tensioners or torque multipliers when installing high capacity working load hoist rings.

For example, a 200,000 lb. WLL Hoist Ring requires the mounting bolt to be torqued to 19,800 lbs-ft. while ADB®'s EZ-Torque® requires only a standard torque wrench and 193 lbs-ft of torque per screw.

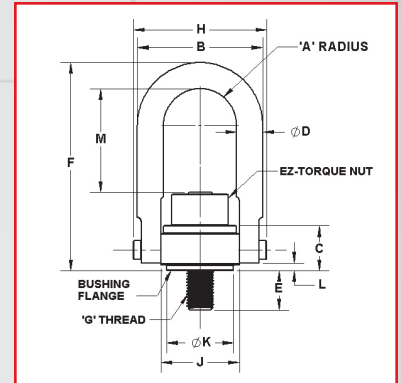

STANDARD

All dimensions approximate - variations do not effect use or safety factor.

Part No.	Rated Load (lbs)	A	B	C	D	E +/- .12	F	G	H	J	K	L	M	TL (ft-lbs)	EZ-Torque® (ft-lbs)*	Weight (lbs)
23490	15,000	1.75	6.0	2.11	1 1/4	1.89	8.73	1-1/4"-7	6.50	3.76	3.20	0.35	3.88	470	10	16.00
23494	24,000	2.25	8.0	2.81	1 3/4	2.70	12.47	1-1/2"-6	8.55	4.87	4.20	0.47	6.12	800	18	37.75
23290	30,000	2.25	8.0	2.81	1 3/4	2.96	12.47	2"-4-1/2	8.55	4.87	4.20	0.47	6.12	1100	23	39.00
23590	50,000	3.00	10.5	4.09	2 1/4	4.00	16.87	2-1/2"-8	11.67	6.52	5.75	1.12	7.73	2100	49	92.00
23592	50,000	3.00	10.5	4.09	2 1/4	4.00	16.87	2-1/2"-4	11.67	6.52	5.75	1.12	7.73	2100	49	92.00
23690	75,000	3.75	13.0	5.27	2 3/4	5.20	19.50	3"-4	14.15	8.10	7.25	1.00	8.53	4300	92	174.60
23790	100,000	4.00	14.5	6.06	3 1/4	7.00	22.09	3-1/2"-4	15.90	8.60	7.75	1.09	9.28	6600	98	246.94
23792	150,000	5.00	18.0	7.50	4	8.50	27.38	4 1/4"-4	19.69	10.75	9.87	1.33	12.93	12000	123	527.00
23794	200,000	6.00	22.0	9.00	5	9.00	33.00	5"-4	24.00	13.00	12.38	1.88	15.00	19800	193	763.00
23798	250,000	6.00	22.0	9.00	5	9.00	33.00	6"-4	24.00	13.00	12.38	1.88	15.00	29000	207	841.00

* Recommended Torque Load per each installation bolt.
• Larger WLL available upon request

METRIC

All dimensions approximate - variations do not effect use or safety factor. Dimensions are in millimeters.

Part No.	Rated Load (kg)	A	B	C	D	E +/- 3.0	F	G	H	J	K	L	M	TL (Nm)	EZ-Torque® (Nm)*	Weight (kg)
24490	7,000	44.5	152.4	53.6	31.8	66	221.7	M30x3.5	165.1	95.5	81.3	8.9	106.3	637.2	13.5	7.26
24494	11,000	57.2	203.2	71.4	44.5	69	316.7	M36x4.0	217.2	123.7	106.7	11.9	164.8	1085.5	20.8	17.13
24498	12,500	57.2	203.2	71.4	44.5	79	316.7	M42x4.5	217.2	123.7	106.7	11.9	158.8	1085.5	21.6	17.13
24290	13,500	57.2	203.2	71.4	44.5	79	316.7	M48x5.0	217.2	123.7	106.7	11.9	152.8	1085.5	21.3	17.69
24592	22,000	76.2	266.7	104.0	57.2	102	428.5	M64x6.0	296.4	165.6	146.1	28.4	203.3	2847.5	53.9	41.73
24690	31,500	95.2	330.2	133.9	69.8	132	495.3	M72x6.0	368.3	205.7	184.1	25.4	215.4	5670.0	124.7	79.20
24790	51,000	101.6	368.3	153.9	82.5	178	561.1	M90x6.0	403.9	218.4	196.8	27.7	235.7	9560.0	132.8	112.01

* Recommended Torque Load per each installation bolt.
• Larger WLL available upon request



HEAVY DUTY® SIDE PULL HOIST RING

- Self-aligning in the direction of the load
- Rotates 360° Under Load
- Minimum of 5:1 design factor in any direction
- Alloy steel, black oxide finish
- Magnetic Particle Inspected Per ASTM 1444



Patent No. 6,267,422

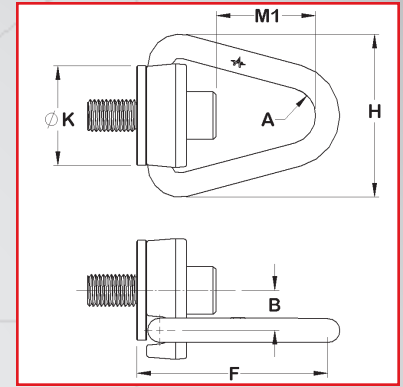
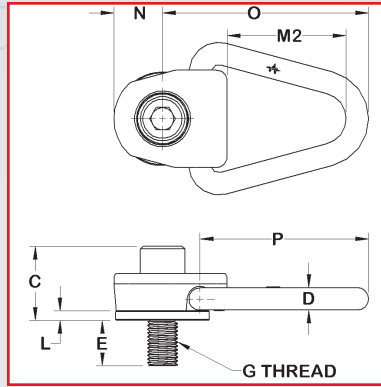

STANDARD

Part No.	Rated Load (lbs)	G	A	B	C	D	E +/- .12	F	H	K	L	M1	M2	N	O	P	TL (ft-lbs)	Weight (lbs)
36305	800	5/16-18	3/4	7/8	1 21/64	1/2	.479	4 23/32	3 7/8	2 3/16	7/32	2 57/64	3 3/16	1 1/4	5 1/8	4 1/4	7	2.05
36310	1000	3/8-16	3/4	7/8	1 25/64	1/2	.479	4 23/32	3 7/8	2 3/16	7/32	2 27/32	3 3/16	1 1/4	5 1/8	4 1/4	12	2.12
36315	2500	1/2-13	3/4	7/8	1 17/32	1/2	.979	4 23/32	3 7/8	2 3/16	7/32	2 45/64	3 3/16	1 1/4	5 1/8	4 1/4	28	2.12
36320	4000	5/8-11	3/4	7/8	1 41/64	1/2	.979	4 23/32	3 7/8	2 3/16	7/32	2 59/64	3 3/16	1 1/4	5 1/8	4 1/4	60	2.22
36325	5000	3/4-10	3/4	7/8	1 25/32	1/2	1.229	4 23/32	3 7/8	2 3/16	7/32	2 15/16	3 3/16	1 1/4	5 1/8	4 1/4	100	2.34
36330	7000	3/4-10	7/8	1 1/4	2 1/4	3/4	1 1/4	6 1/4	5 1/4	3 1/8	5/16	4	4 3/16	1 5/8	6 3/4	5 5/8	100	6.01
36335	8000	7/8-9	7/8	1 1/4	2 3/8	3/4	1 1/4	6 1/4	5 1/4	3 1/8	5/16	3 7/8	4 3/16	1 5/8	6 3/4	5 5/8	160	6.13
36340	10000	1-8	7/8	1 1/4	2 1/2	3/4	1 1/2	6 1/4	5 1/4	3 1/8	5/16	3 3/4	4 3/16	1 5/8	6 3/4	5 5/8	230	6.20

METRIC

Part No.	Rated Load (kg)	G	A	B	C	D	E +/- 3.0	F	H	K	L	M1	M2	N	O	P	TL (Nm)	Weight (kg)
36805	400	M8 x 1.25	19	22	34	13	14	120	99	56	5	73	81	32	130	108	9.5	.93
36810	450	M10 x 1.5	19	22	36	13	24	120	99	56	5	71	81	32	130	108	16.0	.96
36815	1050	M12 x 1.75	19	22	38	13	37	120	99	56	5	69	81	32	130	108	37.0	.96
36820	1900	M16 x 2.0	19	22	42	13	37	120	99	56	5	65	81	32	130	108	80.0	1.01
36825	2200	M20 x 2.5	19	22	46	13	37	120	99	56	5	61	81	32	130	108	135.0	1.07
36830	3000	M20 x 2.5	22	32	57	19	39	159	133	79	8	83	106	41	171	143	135.0	2.73
36835	4200	M24 x 3.0	22	32	61	19	43	159	133	79	8	79	106	41	171	143	311.0	2.78

SIDE PULL HOIST RINGS

The ADB® SIDE PULL Hoist Ring is designed for side lifting. Full swivel and pivot action allows you to flip and turn parts without unhooking. The large weldless ring can accommodate larger hooks.

- Alloy Steel (Certified Heat Treat)
- 5:1 Design Factor
- Swivel 360° Under Load
- Magnaflux inspected
- Black Oxide Finish
- Meets Military Specification No. MIL-STD-209C or MIL-STD-1365(11)

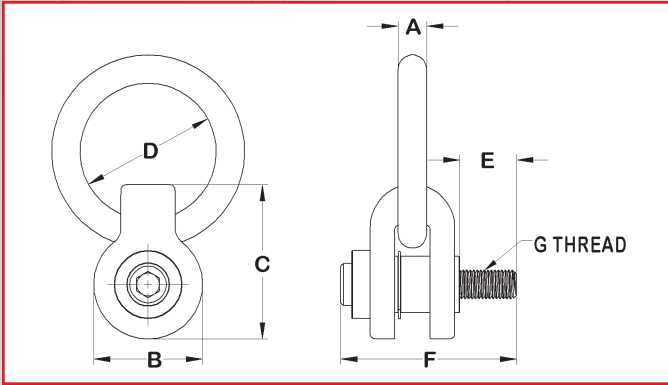

STANDARD

Part No.	Load Capacity (lbs)	A	B	C	D	E +/- .12	F	G	TL* (ft-lbs)	Weight (lbs)
36110	650	3/8	1 1/2	2	2	5/8	2 5/16	5/16-18	3.5	.25
36115	800	3/8	1 1/2	2	2	3/4	2 5/8	3/8-16	4.5	.25
36120	1800	5/8	2 3/8	3 3/16	3	1	3 1/2	1/2-13	15.0	3.25
36125	2500	5/8	2 3/8	3 3/16	3	1 1/4	3 7/8	5/8-11	25.0	3.25
36130	4100	1	3 3/4	5	4	1 1/2	5 3/4	3/4-10	50.0	11.25
36135	7100	1	3 3/4	5	4	1 3/4	6	1-8	90.0	11.50
36140	14000	1 3/8	4 5/8	6 13/16	6	2	6 7/8	1 1/4-7	150.0	27.75
36143	14000	1 3/8	4 5/8	6 13/16	6	2	6 7/8	1 1/4-8	150.0	27.75
36145	17200	1 3/8	4 5/8	6 13/16	6	2 1/2	7 7/8	1 1/2-6	250.0	31.50
36148	17200	1 3/8	4 5/8	6 13/16	6	2 1/2	7 7/8	1 1/2-8	250.0	31.50
36150	29000	1 1/2	4 5/8	6 13/16	5 1/4 x 10 1/2	3 1/8	8 9/16	2-4 1/2	300.0	42.00
36155	29000	1 1/2	4 5/8	6 13/16	5 1/4 x 10 1/2	3 1/8	8 9/16	2-8	300.0	42.00

METRIC

Part No.	Load Capacity (kg)	A	B	C	D	E +/- 3.0	F	G	TL* (Nm)	Weight (kg)
36710	400	9.5	38.1	50.8	50.8	16.0	54.1	M8 x 1.25	8	0.1
36715	650	9.5	38.1	50.8	50.8	20.0	58.1	M10 x 1.5	16	0.1
36720	900	15.9	60.3	81.0	76.2	24.0	84.33	M12 x 1.75	27	1.5
36725	1600	15.9	60.3	81.0	76.2	32.0	120.9	M16 x 2.0	64	1.5
36730	2500	25.4	95.3	127.0	101.6	40.0	128.9	M20 x 2.5	125	5.2
36735	3500	25.4	95.3	127.0	101.6	48.0	136.9	M24 x 3.0	210	5.2
36740	5500	34.9	117.5	173.0	152.4	60.0	166.2	M30 x 3.5	413	12.6
36745	8000	34.9	117.5	173.0	152.4	72.0	178.2	M36 x 4.0	720	14.5
36748	11000	34.9	117.5	173.0	152.4	84.0	190.2	M42 x 4.5	1156	14.5
36750	14000	38.1	117.5	173.0	133.4 x 266.7	96.0	202.2	M48 x 5.0	1681	19.2
36755	25000	38.1	117.5	173.0	133.4 x 266.7	128.0	234.2	M64 x 6.0	4002	19.2

* Standard Torque Load.



FLIP-FLOP HOIST RINGS

- Forged Chrome Moly Steel
- Heat Treated
- Black Oxide Finish
- Pivot 180° Under Load
- 6:1 Design Factor
- High strength screws are 100% Magnaflux Inspected
- Rings and bodies are Magnafluxed per ASTM 1444



Part No. †	Part No. (With Screws)	Rated Load* (lbs)	A	B	C	D	E	F	G	H	R	TL (ft-lbs)	Weight (lbs)	Weight With Screws (lbs)
34030	34030S	2,000	2"	1-3/4"	1"	5/16"	2-1/2"	3/4"	5/16 (2 PLCS)	0"	1/2"	4-7"	.54	.58
34035	34035S	2,500	2-1/2"	2-1/4"	1-1/8"	3/8"	3-3/16"	7/8"	3/8 (2 PLCS)	0"	5/8"	7-10"	1.02	1.07
34040	34040S	5,000	3"	2-5/8"	1-1/2"	1/2"	3-7/8"	1-1/8"	1/2 (2 PLCS)	0"	3/4"	20-25"	1.92	2.06
34045	34045S	12,000	4"	3-1/8"	1-5/8"	3/4"	5-1/4"	1-3/8"	1/2 (4 PLCS)	1-1/4"	7/8"	20-25"	3.94	4.10
34050	34050S	20,000	5"	3-5/8"	2-1/16"	1"	6-3/16"	1-7/8"	5/8 (4 PLCS)	1-1/4"	1"	42-50"	7.44	7.94

*To obtain maximum load capacity, high strength screws must be used.

† Mounting Screws Not Included

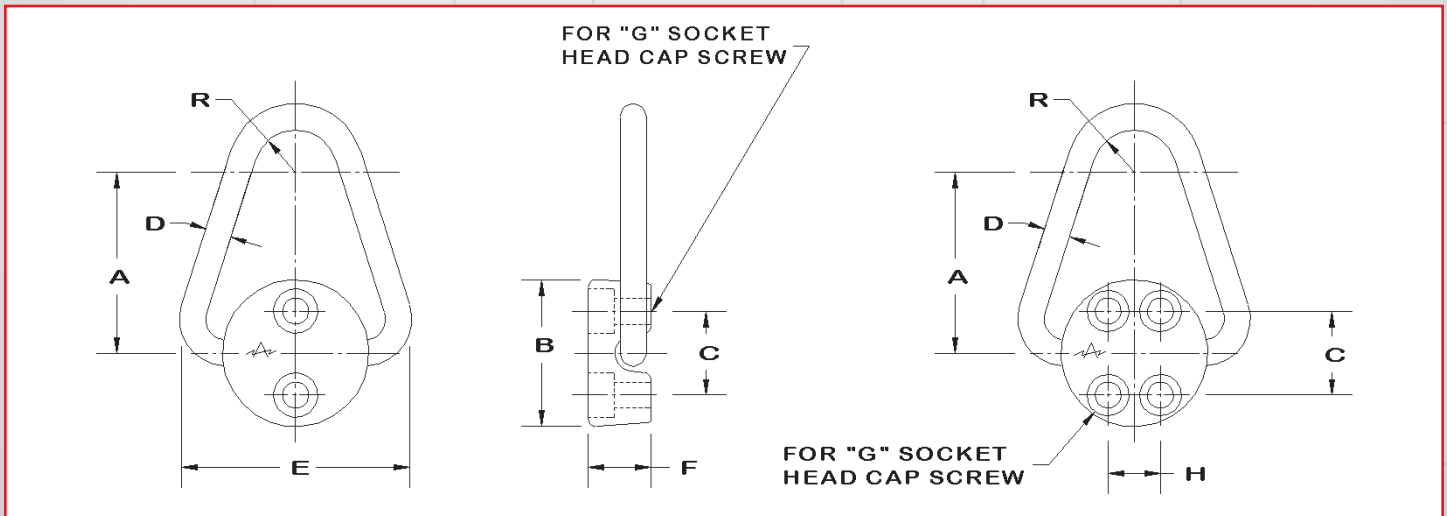

*HIGH STRENGTH SCREW

Part No.	Used P/N	Screw Thd	Screw Length	Weight (lbs)
23812	34030	5/16-18	1-1/4"	.04
23813	34035	3/8-16	1-1/4"	.05
23804	34040	1/2-13	2"	.14
23805	34045	1/2-13	2-1/4"	.16
33645	34050	5/8-11	2-3/4"	.50



FAST-LOK® PLATE LIFTING SYSTEM



The Fast-Lok Pin is designed for use in applications where quick and easy removal is desired. The user is reminded to insure pin is properly installed prior to applying load.

NOTE: Minimum ultimate load is 6 times the working load limit. Bolt type anchor shackles supplied with thin head bolt & nut with cotter pin. Meets Federal Specification RR-C 271D, Type IVA, Grade A, Class 3.

Also available with Fast-Lok Pin.

Part No.	Rated Load (lbs)	Description
36906	10,000	FAST-LOK SYSTEM
36905	10,000	FAST-LOK
36903	10,000	FAST LOK PIN
36900	10,000	FAST-LOK PLATE
36551	10,000	BOLT TYPE ANCHOR SHACKLE

WELD-IN THREADED INSERTS

- Material: High Tensile Alloy Steel
- Certified Heat Treatment
- Welding instructions included with each shipment

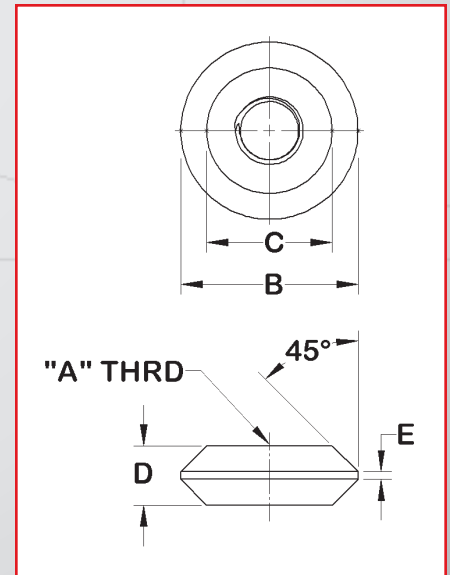

Part No.	Thread Type	A	B	C	D	E
36986	COIL	1 1/4	3	2-1/8	1	1/8
36992	COIL	1 1/2	3-1/2	2-3/8	1-1/2	3/8

SPIN-N-LOK™ HOIST RING

1. Ideal for lifting and moving road plates
2. Star base spins and engages thread into weld in insert
3. Replaceable stud

- Pivots 180° and Swivels 360° Under Load
- Material: High Tensile Alloy Steel
- Finish: Black Oxide
- Design Factor: Minimum of 5:1
- Magnetic Particle Inspected Per ASTM 1444

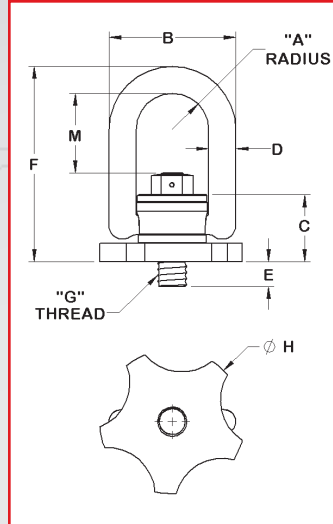

Part No.	Rated Load (lbs)	A	B	C	D	E +/- .12	F	G	Thread Type	H	M	Weight (lbs)
36960	10000	1.4	5.1	2.8	1	1	8 1/8	1 1/4	COIL	6	2.95	12.20
36965	10000	1.4	5.1	2.8	1	1	8 1/8	1 1/2	COIL	6	2.95	13.35

* Customized Threads Available Upon Request

HEAVY DUTY® ROAD PLATE HOIST RING

- Material: High strength 4140 alloy steel
- Range of movement: Swivel 360°, Pivot 180° Under Load
- Design Factor: Minimum of 5:1
- Meets manufacturing and design requirements of ASME-B30.26 and MIL-STD 209
- Magnetic Particle Inspected Per ASTM 1444
- Black oxide coated

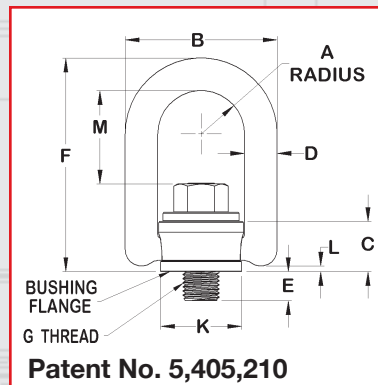

Part No.	*Rated Load	A	B	C	D	E +/- .12	F	G	K	TL (ft/lbs)	M	Weight (lbs)
36660	†10,000	1.40	5.10	2.05	1.00	1	7.00	1 1/4-7	2.81	230	2.95	8.09
36665	†10,000	1.40	5.10	2.05	1.00	1 1/2	7.00	1 1/2-6	2.81	230	2.95	8.22
36670	†15,000	2.00	6.75	2.87	1.25	1	9.22	1 1/4-7	3.88	470	3.74	18.32
36675	†15,000	2.00	6.75	2.87	1.25	1 1/2	9.22	1 1/2-6	3.88	470	3.74	18.80

HEAVY DUTY® WELD-MOUNT HOIST RING



- Swivel 360° and Pivot 180° Under Load
- Material: High strength 4140 alloy steel
- Safety Factor: 5:1
- Finish: Black Oxide per Mil C-13924B
- Magnetic Particle Inspected Per ASTM 1444

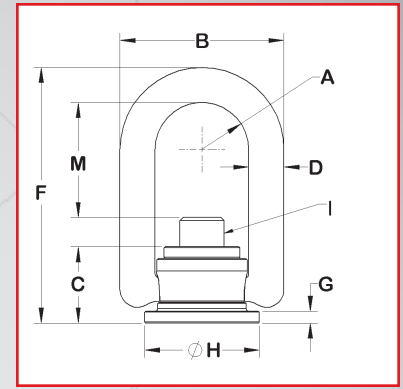

Part No.	†Rated Load (lbs)	A	B	C	D	F	G	H	I SHCS	M
36640	†5,000	1.00	3.50	1.63	0.75	5.47	1/4	2.45	5/8-11	2.46
36645	†10,000	1.50	5.10	2.30	1.00	7.64	3/8	3.51	1-8	3.22
36650	†24,000	2.00	6.75	3.12	1.25	9.50	1/2	4.70	1 1/4-7	3.63

†Note: Rated load applies to hoist ring assembly only. Workpiece material must be capable of supporting this weight. Welding should be done by certified welder for maximum safety.
Patent No. 5,405,210

SCISSOR-LOK™ SYSTEM

Ideal for lifting and moving street/road plates New lightweight design

- Pivot 180°
- Material: High Tensile Alloy Steel
- Finish: Black Oxide
- Safety Factor: Minimum of 5:1
- Magnetic Particle Inspected Per ASTM 1444

Part No.	Rated Load (lbs)	Description
36860	10000	SCISSOR-LOK TOOL
36865	10000	SCISSOR-LOK SYSTEM
36900	10000	FAST-LOK PLATE
36903	10000	FAST-LOK PIN

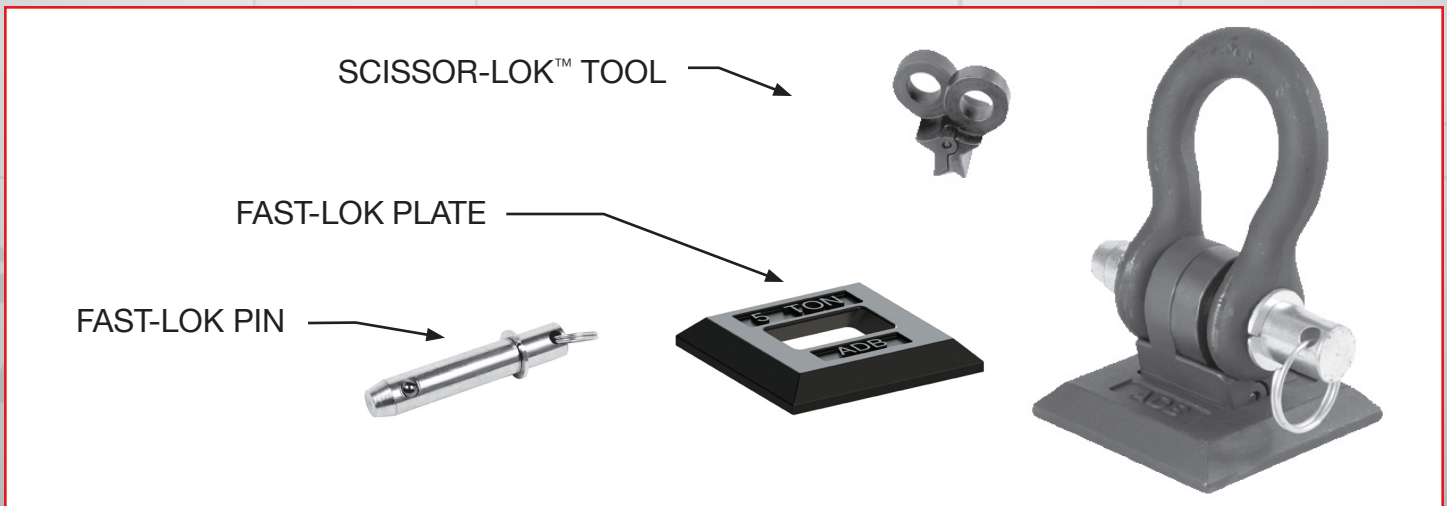

SUPER-COIL® HOIST RINGS

- Alloy Steel, Black Oxide Finish
- Excellent for temporary attachment to steel & construction material
- Range of movement: pivot 180° & swivel 360° to compensate for pitch, pull and sway when lifting unbalanced loads. Load ratings are for lifts in any direction.
- Minimum Design Factor: 5.1
- Magnetic Particle Inspected Per ASTM 1444
- Destructive testing by outside independent laboratories
- ADB® Coil Bolts are included to ensure the integrity of the product

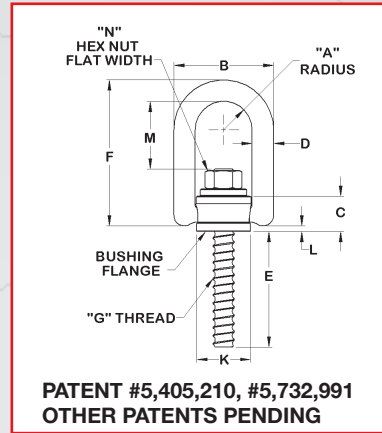

Part No.	Rated Load (lbs)	A	B	C	D	E* +/- .12	F	G THD.	K	TL (ft-lbs)	L	M	N	Weight (lbs)
33716CT	5,000	1.00	3.50	1.50	.75	4.00	5.31	3/4	1.89	100	.17	2.31	1 1/8	2.3
33107CT	10,000	1.40	5.10	2.05	1.00	5.00	7.00	1	2.81	230	.18	2.95	1 1/2	8.4
33401CT	15,000	2.00	6.75	2.87	1.25	6.00	9.22	1 1/4	3.88	470	.32	3.74	1 7/8	17.5
33424CT	24,000	2.00	6.75	2.87	1.25	7.00	9.22	1 1/2	3.88	800	.32	3.49	2 1/4	20.3

* Longer projections are available, call factory for quotation,

HEAVY DUTY® SWIVEL/PIVOT LIFT PLATE

- Pivots 180°/Swivels 360°
- Material: High strength 4140 alloy steel
- Design Factor: 5:1
- Finish: Black Oxide per Mil C-13924B
- Magnetic Particle Inspected Per ASTM 1444
- Bolt/Coil insert not included**

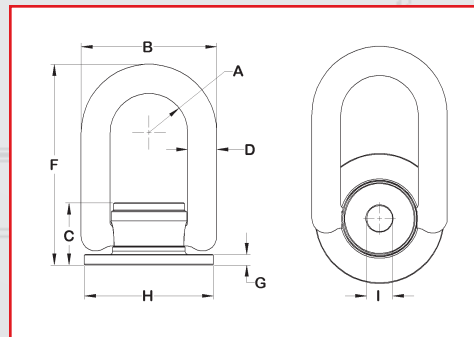

Part No.	*Rated Load (lbs)	A	B	C	D	F	G	H	I	Weight (lbs)
36600	7,000	1.40	5.10	2.39	1.00	7.00	13/32	5	3/4	8.95
36605	10,000	1.40	5.10	2.39	1.00	7.00	13/32	5	1	8.95

*Note: Rated load is based on 180,000 psi ultimate tensile strength of bolt or stud. If a bolt with lower strength is used or workpiece anchor material is incapable of supporting this weight, the applied load must be reduced accordingly.

Patent No. 5,405,210



BOLT TYPE ANCHOR SHACKLE

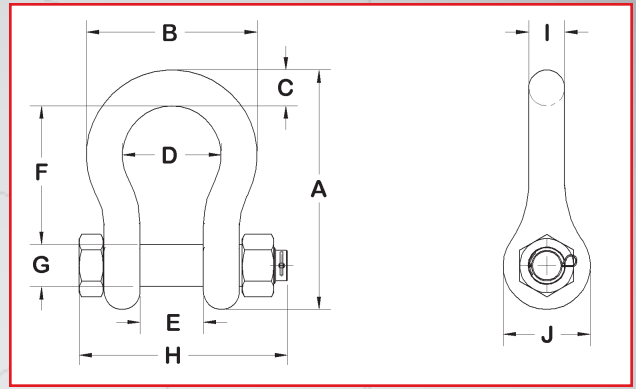

Part No.	Nominal Shackle Size (in) C	Working Load Limit (lbs)	DIMENSION									Weight (lbs)
			A	B	D	E	F	G	H	I	J	
36511	3/8	2,000	2.49	1.78	1.03	.66	1.44	.44	2.17	.38	.91	.33
36521	7/16	3,000	2.91	2.03	1.16	.75	1.69	.50	2.51	.44	1.06	.49
36531	1/2	4,000	3.28	2.31	1.31	.81	1.88	.63	2.80	.50	1.19	.79
36541	5/8	6,500	4.19	2.94	1.69	1.06	2.38	.75	3.53	.63	1.50	1.68
36551	7/8	13,000	5.83	4.03	2.28	1.44	3.31	1.00	4.71	.88	2.09	3.95
36561	1-1/8	19,000	7.47	5.16	2.91	1.81	4.25	1.25	6.00	1.13	2.69	8.27
36571	1-1/4	24,000	8.25	5.75	3.25	2.03	4.69	1.38	6.51	1.25	3.00	11.71

*NOTE: Minimum ultimate load is 6 times the working load limit.
Bolt type anchor shackles supplied with thin head bolt & nut with cotter pin.
Meets Federal Specification RR-C 271D, Type IVA, Grade B, Class 3

WELDLESS ALLOY RINGS

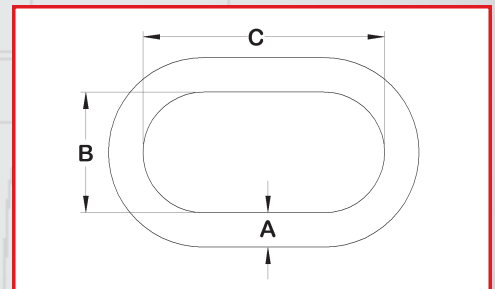

Part No.	Working Load Limit (lbs)	Material Diameter A	Inside Dia. of Ring B	Length of Oval C	Weight (lbs)
36111	3,800	3/8	2		.23
36121	6,100	5/8	3		1.00
36131	18,400	1	4		3.40
36141	30,000	1 3/8	6		10.38
36151	49,000	1 1/2	5.25	10.5	15.70

*NOTE: Minimum ultimate load is 6 times the working load limit.
Rings meet Federal Specification RR-C 271D, Type VI

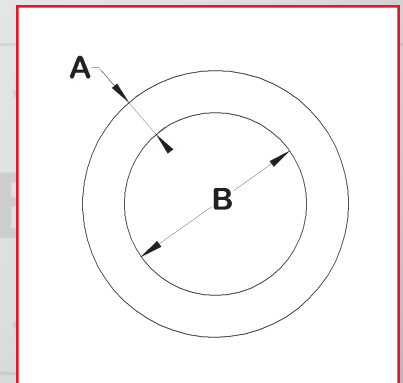

SHACKLE HOIST RINGS

The ADB® Shackle Hoist Ring is used for OEM applications and permanent mounting on dies, molds, fixtures or equipment. Can be bolted or welded in place.



- Alloy Steel, Black Oxide Finish
- Swivel 360° and Pivot 180° Under Load
- Design Factor = 5.1
- Magnetic Particle Inspected Per ASTM 1444
- Ideal for lifting large and heavy structures

Patent No. 5,823,588

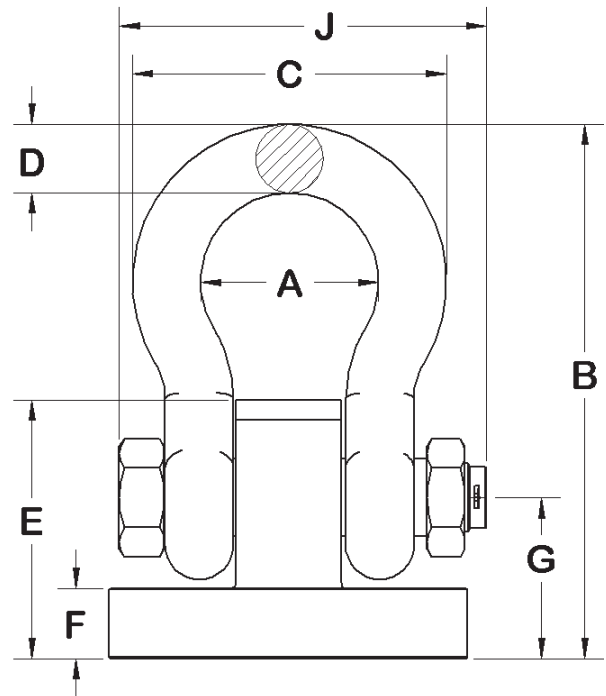
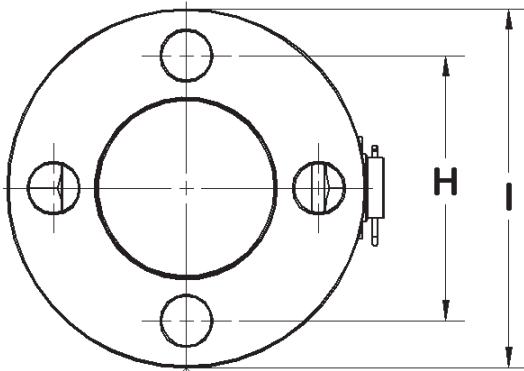

Part No.	Rated Load (lbs)	Screw Size	A	B	C	D	E	F	G	H	I	J	Weight (lbs)
36510	2000	1/4-20 x 1/2	1.03	2.96	1.78	3/8	1.43	0.40	0.91	1.56	2.10	2.17	0.80
36520	3000	5/16-18 x 1/2	1.16	3.55	2.03	7/16	1.76	0.52	1.16	1.76	2.40	2.51	1.30
36530	4000	3/8-16 x 5/8	1.31	3.91	2.31	1/2	1.91	0.52	1.21	2.10	2.90	2.80	2.04
36540	6500	7/16-14 x 3/4	1.69	4.97	2.94	5/8	2.41	0.64	1.51	2.56	3.50	3.53	3.80
36550	13000	5/8-11 x 1	2.28	6.85	4.03	7/8	3.31	0.90	2.06	3.40	4.60	4.71	9.55
36560	19000	3/4-10 x 1 1/4	2.91	8.75	5.16	1-1/8	4.01	1.14	2.61	4.00	5.40	5.09	18.10
36570	24000	7/8-9 x 2	3.25	9.68	5.75	1-1/4	4.51	1.30	2.91	4.50	6.10	6.51	25.70

UNIVERSAL LIFT RINGS

A tool used for vertical lifting only

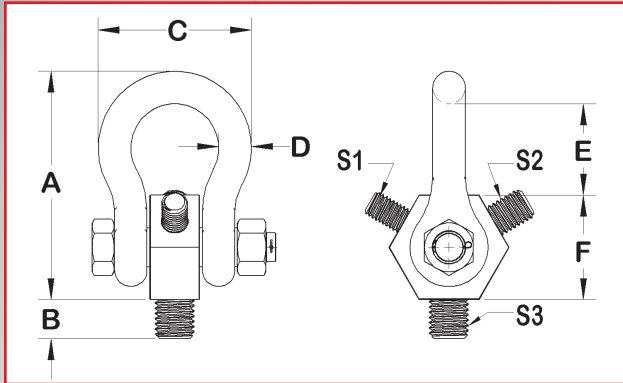

Some typical applications for the ADB® universal lift rings are:

1. Large Chucks
2. Milling Cutters
3. Dies
4. Broaches
5. Motors
6. Fixtures
7. Small Machines
8. Machined Parts

Caution: Do not apply side load

For straight lift only. Listed capacities are maximum safe working load.

STANDARD

Part No.		Screw Size	Capacity (lbs)*	A	B +/- .12	C	D	E	F	Weight (lbs)
34005	S1	1/4-20	400	3-1/16	1/2	2-1/8	7/16	1-1/4	1-3/8	0.8
	S2	5/16-18	800	3-1/16	1/2	2-1/8	7/16	1-1/4	1-3/8	
	S3	3/8-16	1,400	3-1/16	1/2	2-1/8	7/16	1-1/4	1-3/8	
34010	S1	1/2-13	2,600	4-3/8	3/4	3	5/8	1-3/4	2	2.5
	S2	5/8-11	4,000	4-3/8	3/4	3	5/8	1-3/4	2	
	S3	3/4-10	6,000	4-3/8	3/4	3	5/8	1-3/4	2	

STANDARD - Fine Thread

Part No.		Screw Size	Capacity (lbs)*	A	B +/- .12	C	D	E	F	Weight (lbs)
36005	S1	1/4-28	400	3-1/16	1/2	2-1/8	7/16	1-1/4	1-3/8	0.8
	S2	5/16-24	800	3-1/16	1/2	2-1/8	7/16	1-1/4	1-3/8	
	S3	3/8-24	1,400	3-1/16	1/2	2-1/8	7/16	1-1/4	1-3/8	
36010	S1	1/2-20	2,600	4-3/8	3/4	3	5/8	1-3/4	2	2.5
	S2	5/8-18	4,000	4-3/8	3/4	3	5/8	1-3/4	2	
	S3	3/4-16	6,000	4-3/8	3/4	3	5/8	1-3/4	2	

METRIC

Part No.		Screw Size	Capacity (kg)	A	B +/- 3.0	C	D	E	F	Weight (kg)
35005	S1	M8-1.25	400	77.8	13	53.98	11.11	31.8	34.93	0.36
	S2	M10-1.50	450	77.8	13	53.98	11.11	31.8	34.93	
	S3	M12-1.75	1,050	77.8	13	53.98	11.11	31.8	34.93	
35010	S1	M14-2.00	1,050	111.13	19	76.2	15.9	44.5	50.8	1.13
	S2	M16-2.00	1,900	111.13	19	76.2	15.9	44.5	50.8	
	S3	M20-2.50	2,200	111.13	19	76.2	15.9	44.5	50.8	



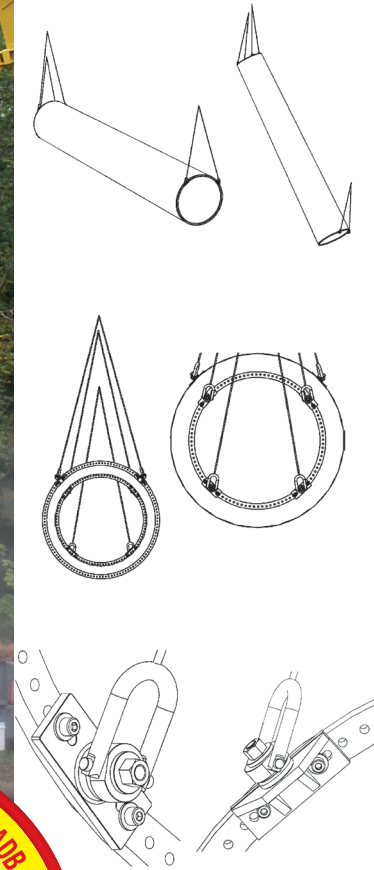

- Designed with Patented Safety Engineered Hoist Rings
- 100 Ton System Working Load Limit
- Swivel 360° and Pivot 180° Under Load
- Greatly Reduces Sling Bind
- Adjustable for Universal Fit On Most Towers
- 100% Technical Support from Quote to Final Lift

TOP FLANGE TOOL

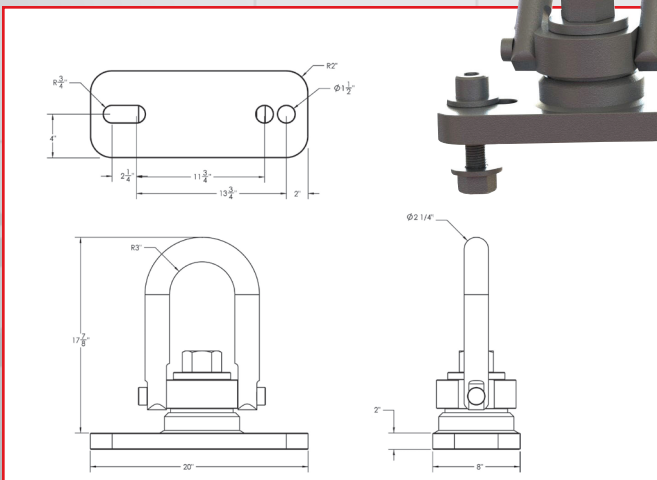

BOTTOM FLANGE TOOL

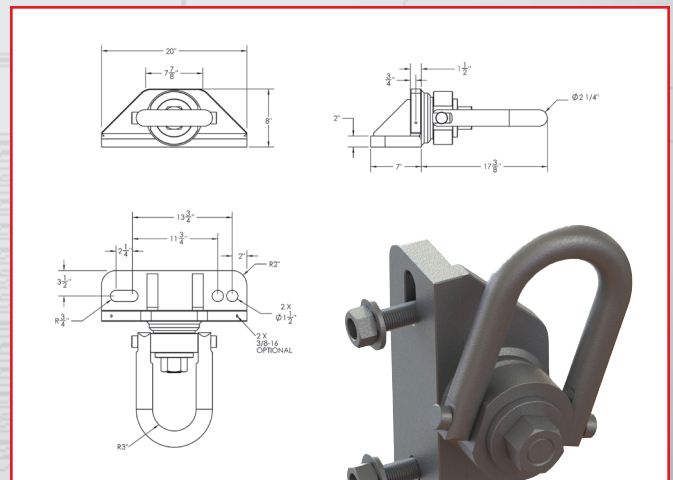

REPLACEMENT SCREWS - STANDARD

	Hoist Ring Part Number	Screw Part Number	Hoist Ring Capacity (lbs)	Screw Size	Effective Thrd. Proj.
Safety Engineered	23001	23021S	4,000	5/8-11	.78
	23002	23022S	4,000	5/8-11	1.03
	23003	23023S	4,000	5/8-11	1.28
	23004	23024S	2,500	1/2-13	.78
	23005	23025S	2,500	1/2-13	1.03
	23006	23026S	2,500	1/2-13	1.28
	23007	23027S	5,000	3/4-10	1.03
	23009	23029S	5,000	3/4-10	1.53
	23050	23041S	550	1/4-20	.54
	23051	23071S	800	5/16-18	.29
	23052	23072S	800	5/16-18	.54
	23053	23073S	1,000	3/18-16	.54
	23101	23121S	8,000	7/8-9	1.04
	23102	23122S	7,000	3/4-10	1.04
	23103	23123S	7,000	3/4-10	1.54
	23105	23125S	10,000	1-8	1.29
	23106	23126S	10,000	1-8	1.54
	23107	23127S	10,000	1-8	2.29
	23202	23222S	24,000	1 1/2-6	2.70
	23301	23318S	2,500	1/2-13	1.07
	23320	23022S	4,000	5/8-11	1.03
	23321	23023S	4,000	5/8-11	1.28
	23322	23024S	2,500	1/2-13	.78
	23323	23025S	2,500	1/2-13	1.03
	23324	23026S	2,500	1/2-13	1.28
	23325	23027S	5,000	3/4-10	1.03
	23327	23029S	5,000	3/4-10	1.53
	23328	23121S	8,000	7/8-9	1.04
	23329	23122S	7,000	3/4-10	1.04
	23330	23123S	7,000	3/4-10	1.54
	23331	23125S	10,000	1-8	1.29
	23332	23126S	10,000	1-8	1.54
	23333	23127S	10,000	1-8	2.29
23401	23421S	15,000	1 1/4-7	1.89	
Heavy Duty®	33101	33121S	8,000	7/8-9	1.20
	33102	33122S	7,000	3/4-10	1.20
	33103	33123S	7,000	3/4-10	1.45
	33104	33120S	8,000	7/8-9	0.95
	33105	33125S	10,000	1-8	1.45
	33106	33126S	10,000	1-8	1.20
	33107	33127S	10,000	1-8	2.20
	33108	33119S	7,000	3/4-10	.95
	33112	33152S	550	1/4-20	.56
	33212	33252S	800	5/16-18	.56
	33214	33254S	800	5/16-18	1.06
	33312	33352S	1,000	3/8-16	.56
	33314	33354S	1,000	3/8-16	1.06
	33316	33552S	2,250	1/2-13	1.06
	33401	33421S	15,000	1 1/4-7	2.63
	33402	33419S	15,000	1 1/4-7	1.88
	33420	33429S	20,000	1 3/8-6	2.63
	33424	33422S	24,000	1 1/2-6	2.63
	33512	33554S	2,500	1/2-13	.75
	33515	33555S	2,500	1/2-13	1.00
	33516	33556S	2,500	1/2-13	1.25
	33612	33653S	4,000	5/8-11	.75
	33614	33654S	4,000	5/8-11	1.00
33615	33655S	4,000	5/8-11	1.25	
33714	33754S	5,000	3/4-10	1.00	
33716	33756S	5,000	3/4-10	1.50	



REPLACEMENT SCREWS - METRIC

Hoist Ring Part Number	Screw Part Number	Rated Load (kg)	Screw Size	Effective Thrd. Proj.
34212	34252S	400	M8x1.25	16
34214	34254S	400	M8x1.25	21
34312	34352S	450	M10x1.5	16
34314	34354S	450	M10x1.5	26
34515	34555S	1050	M12x1.75	25
•34505	34555S	1050	M12x1.75	25
34516	34556S	1050	M12x1.75	32
•34517	34556S	1050	M12x1.75	32
34518	34557S	1500	M14x2.0	25
•34519	34557S	1500	M14x2.0	25
34520	34558S	1500	M14x2.0	32
•34521	34558S	1500	M14x2.0	32
34614	34654S	1900	M16x2.0	25
•34604	34654S	1900	M16x2.0	25
34615	34655S	1900	M16x2.0	32
•34616	34655S	1900	M16x2.0	32
34714	34130S	2200	M20x2.5	25
•34715	34130S	2200	M20x2.5	25
34716	34131S	2200	M20x2.5	38
•34717	34131S	2200	M20x2.5	38
34101	34120S	3000	M20x2.5	28
•34161	34120S	3000	M20x2.5	28
34102	34121S	4200	M24x3.0	28
•34162	34121S	4200	M24x3.0	28
34103	34123S	4200	M24x3.0	38
•34163	34123S	4200	M24x3.0	38
34105	34126S	4500	M30x3.5	38
•34165	34126S	4500	M30x3.5	38
34107	34127S	4500	M30x3.5	48
•34167	34127S	4500	M30x3.5	48
34401	34421S	7000	M30x3.5	67
34402	34422S	11000	M36x4.0	67
24008	24208S	400	M8x1.25	17
24010	24210S	450	M10x1.5	17
24012	24212S	1050	M12x1.75	19
•24014	24212S	1050	M12x1.75	19
24016	24216S	1900	M16x2.0	24
•24018	24216S	1900	M16x2.0	24
24020	24220S	2200	M20x2.5	30
•24021	24220S	2200	M20x2.5	30
24022	24222S	3000	M20x2.5	29
•24023	24222S	3000	M20x2.5	29
24024	24224S	4200	M24x3.0	34
•24026	24224S	4200	M24x3.0	34
24030	24230S	4500	M30x3.5	54
•24032	24230S	4500	M30x3.5	54
24040	24421S	7000	M30x3.5	46
24042	24433S	7000	M30x3.5	66
24050	24223S	11000	M36x4.0	69

Heavy Duty®

Safety Engineered

A
RADI

D

US
FLANGE
THREAD

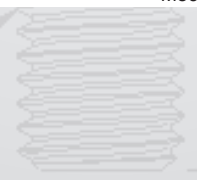

The **SPECIALIST** in **CUSTOMIZED** **HOIST RINGS**

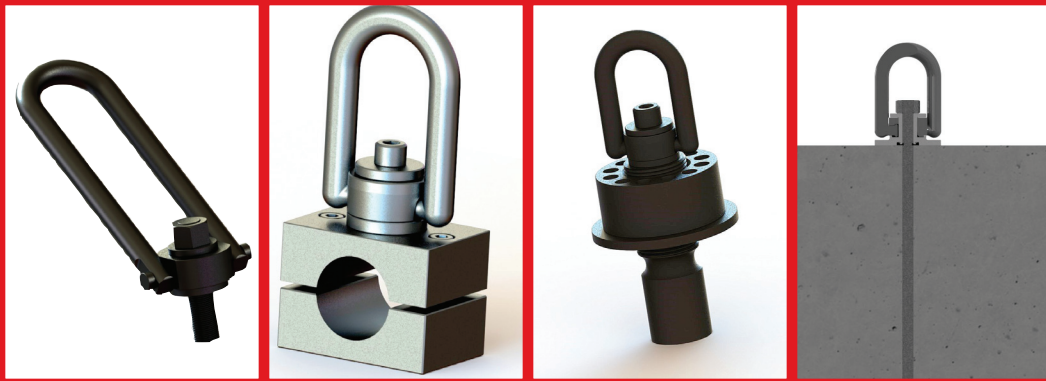

ADB® can assist with any customized lifting solution utilizing hoist rings and will provide a product that has been tested per current lifting and rigging standards which will ensure compliance and the safe lifting solution that is required.

Technical assistance relating to the product from initial design planning to the end use is available.

Allow the ADB® Team to evaluate if a customized or a standard hoist ring is the best lifting tool for your next project.

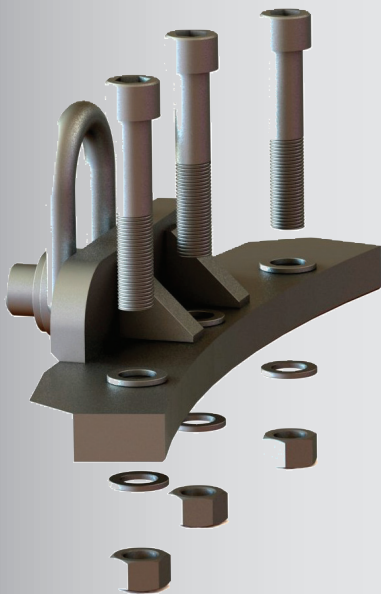

Headquarters:
5740 Hunt Rd. • Valdosta, GA 31606
Phone (800) 423-4425 • Fax (229) 253-8929
www.adbhoiststrings.com
email: adb@adbhoiststrings.com

Copyright ©2012

