

YOKE®

8-2022

Safety is our first priority™



Quality Management System and Product Type Approval:



Industrial Membership:



General Catalog No. 8-2022

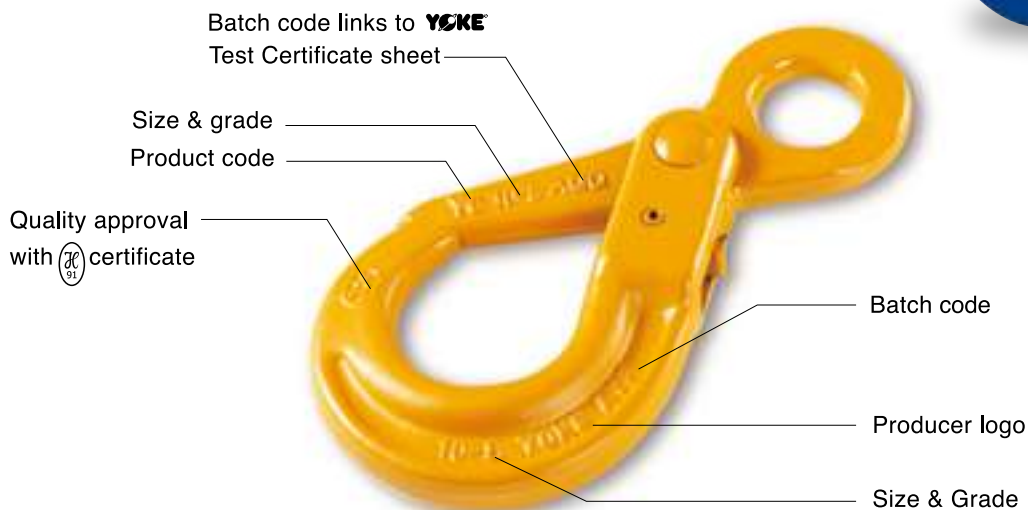
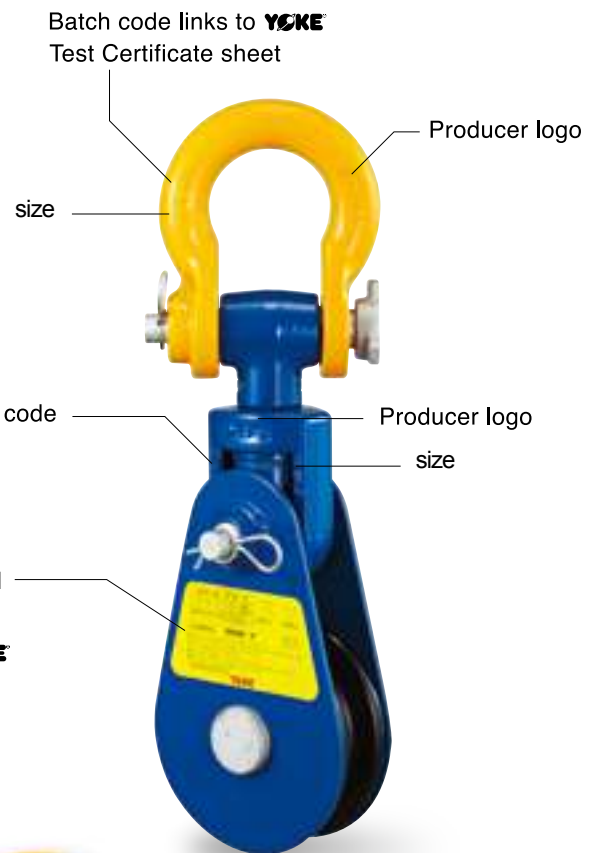
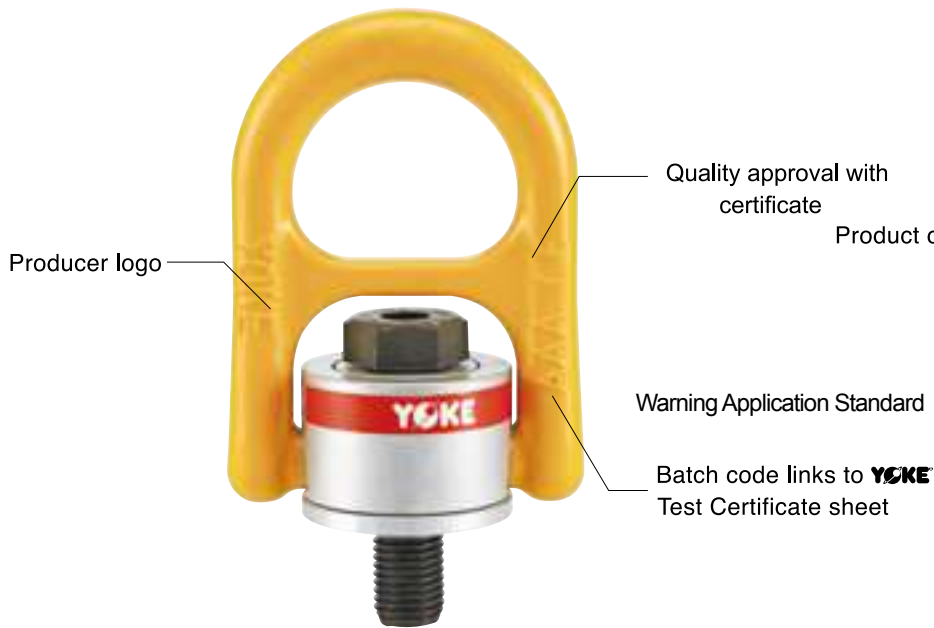
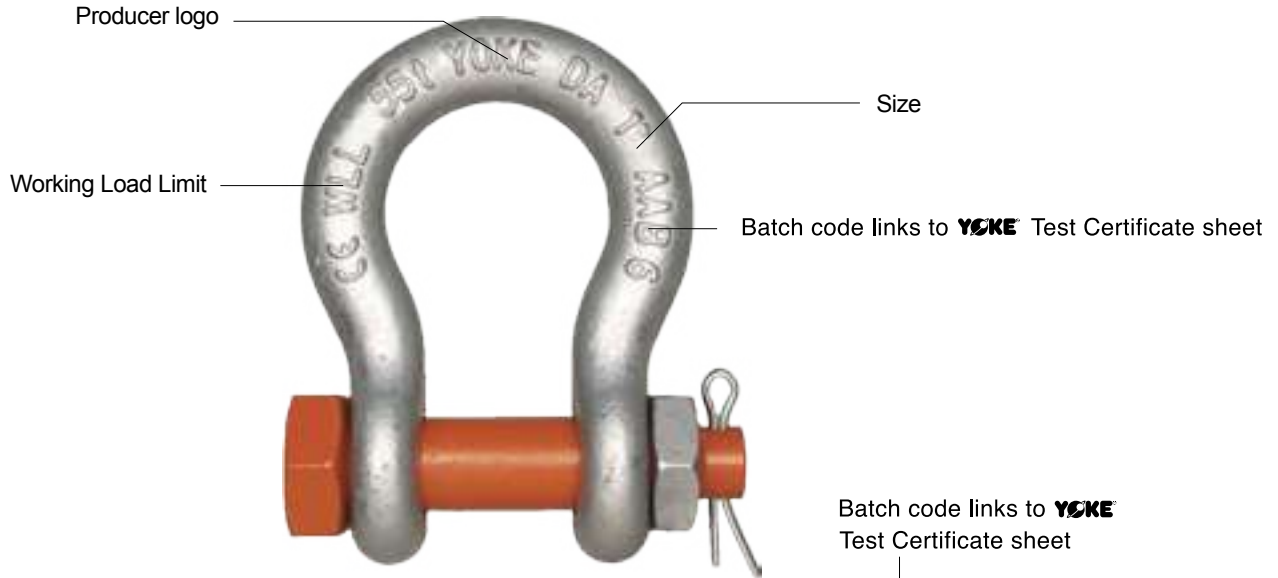

Quality Management System and Product Type Approval:



Statement of LIMITED WARRANTY

Purchaser and YOKE expressly agree that YOKE's warranty with respect to sale of its products is LIMITED solely to YOKE's choice of repair, replacement or refund of the purchase price of any product.

Purchaser and YOKE expressly agree that the remedies provided in this section are the purchaser's exclusive remedies in connection with the purchase or use of the product. Purchaser and YOKE expressly agree that in no event shall YOKE be liable for any incidental or consequential damages in connection with the purchase or use of the product.

All other warranties, including express warranties and the implied warranties of merchantability and fitness for a particular purpose are hereby disclaimed. Purchaser hereby waives all other warranties, rights and remedies arising by law or otherwise including, but not limited to, express warranties, the implied warranty of merchantability, any implied warranties arising from course of performance, course of dealing or usage of trade, and implied warranty of fitness for a particular purpose. Additionally, YOKE hereby disclaims any of its obligations or liabilities arising from statute, warranty, contract, tort or negligence. Any modification made to YOKE products will void the limited warranty where applicable, and will also void any third party accreditations that may apply such as ABS, DNV, etc.

Complete Agreement: This Warranty between purchaser and YOKE is complete. All prior or contemporaneous discussions, representations and/or understanding are merged into this Warranty.

All prior or contemporaneous agreements between the parties are superseded by this Warranty. Choice of Law: Any dispute about the interpretation of this Warranty shall be governed by the laws of Taiwan, The Republic of China.

The Period of Warranty: Shall start from the date of delivery of the product to the customer and shall cover a period of 12 months.

Resolution of Disputes: Purchaser and YOKE expressly agree that any dispute arising out of the purchase, use or operation of the purchased product shall, upon written notice to the other party, be resolved through binding arbitration. The arbitration shall be governed by the then existing rules of the Arbitration Association of The Republic of China. The location of any arbitration shall be Taichung, Taiwan, The Republic of China. The substantive laws of The Republic of China shall govern the arbitration to the extent they are not in conflict with the then existing rules of the Arbitration Association of The Republic of China. In no event shall YOKE be liable for incidental or consequential damages as part of the arbitration award. The award, decision, or filing rendered by the arbitration shall be final, and judgment may be entered upon it in accordance with the applicable law in any court having appropriate jurisdiction.

YOKE INDUSTRIAL CORP.

Quality Control, Testing, and Detecting during manufacturing

YOKE runs a constant and strict production facility with quality control in every manufacturing stage from raw materials to the completed product. YOKE is an ISO 9001 certified company and has Type Approval by the major international authorities from Deutsche Gesetzliche Unfallversicherung (DGUV) , ABS, API, and DNV. YOKE has achieved CNLA certification - Chinese National Laboratory Accreditation which ensures a quality research and development (R&D) department and unsurpassed product engineering.

■ Magnaflux Crack Detection:

All forged components are individually magnaflux detected after heat treatment.

■ Proof Load Testing:

YOKE Yellow Points are proof load qualified to 2.5 times the Working Load Limit within 1% permanent deformation.

■ Dynamic Fatigue Testing:

Batch samples of YOKE Yellow Points are Dynamic Fatigue Tested to 20,000 cycles at 1.5 times the Working Load Limit.

■ Ultimate Breaking Load Testing:

Batch samples are tested in a static tensile testing machine until failure. Minimum ultimate force equals to the Working Load Limit times safety factor.

■ Spectrographic Analysis:

To assure of the proper metallurgy content of all raw materials.



Test certificate
Complied to EN10204

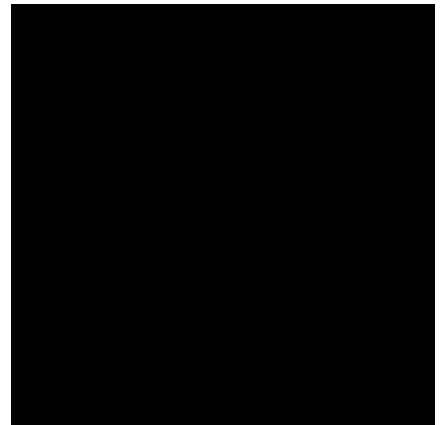



Safety is our first priority™

Safety is our first priority TM

- Quality, Reliability, Innovation -

P.8
Yellow Point



P.69
Grade 100 Lifting
Chain Fittings



P.127
Grade 80 Lifting
Chain Fittings



P.163
DA Series



P.189
ROV
Hooks, Shackles



P.193
Snatch Blocks
Hay Fork Pulleys
Trawl & Blocks



P.221
Shackle
Wire Rope Clip
Angular Contact
Bearing Swivels



P.232
Hoist Hooks



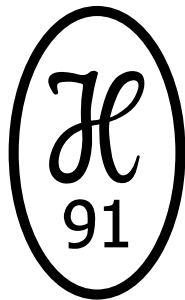







YOKE YP Size & WLL Chart



| | 8-211 | 8-231 | 8-203 | 8-251 | 8-271 | 8-291 | 8-S291 |
|--------|--------|-------|-------|-------|-------|-----------------|--------|
| Thread | WLL(t) | | | | | | |
| M 6 | | | | | | 0.10 NEW | |
| M 8 | 0.30 | 0.50 | 0.50 | 0.30 | 0.40 | 0.30 | |
| M10 | 0.63 | 0.70 | 0.55 | 0.50 | 0.60 | 0.40 | |
| M12 | 1.00 | 1.00 | 1.30 | 0.70 | 0.70 | 0.75 | 0.5 |
| M14 | 1.20 | 1.50 | | 1.00 | | | |
| M16 | 1.50 | 2.00 | 2.40 | 1.40 | 1.50 | 1.50 | 1.0 |
| M18 | 2.00 | 2.50 | | | | | |
| M20 | | | 2.70 | 1.70 | | | |
| | 2.50 | 3.00 | 3.75 | 2.50 | 2.50 | 2.30 | 2.0 |
| M24 | | | | 1.70 | | | |
| | 4.00 | 5.00 | 5.25 | 4.00 | 4.00 | 3.20 | 2.5 |
| M27 | 4.00 | 5.60 | | | | | |
| M30 | | | | 4.00 | | | |
| | | | | 6.70 | | | |
| | 5.00 | 7.80 | 8.75 | 8.00 | 6.00 | 4.50 | |
| M36 | | | | | | | |
| | 7.00 | | | | | | |
| | 8.00 | 12.50 | 13.75 | 10.00 | 10.00 | 7.00 | |
| M42 | | | | 12.50 | | | |
| | 10.00 | | | 13.00 | 13.00 | 9.00 | |
| M45 | | | | 12.50 | | | |
| | | | | 17.00 | | | |
| M48 | | | | 12.50 | | | |
| | 20.00 | 20.00 | 16.90 | 17.00 | 14.00 | 12.00 | |
| M56 | 22.00 | 22.00 | | 18.00 | 20.00 | 16.00 | |
| M64 | | | | 20.00 | | | |
| | 22.50 | 22.50 | | 28.00 | 20.00 | 18.00 | |
| M72 | | | | 28.00 | | | |
| | | | | 35.00 | 40.00 | | |
| M80 | | | | 28.00 | | | |
| | | | | 35.00 | | | |
| | | | | 40.00 | 40.00 | | |
| M90 | | | | 35.00 | | | |
| | | | | 40.00 | 40.00 | | |
| M100 | | | | 40.00 | | | |

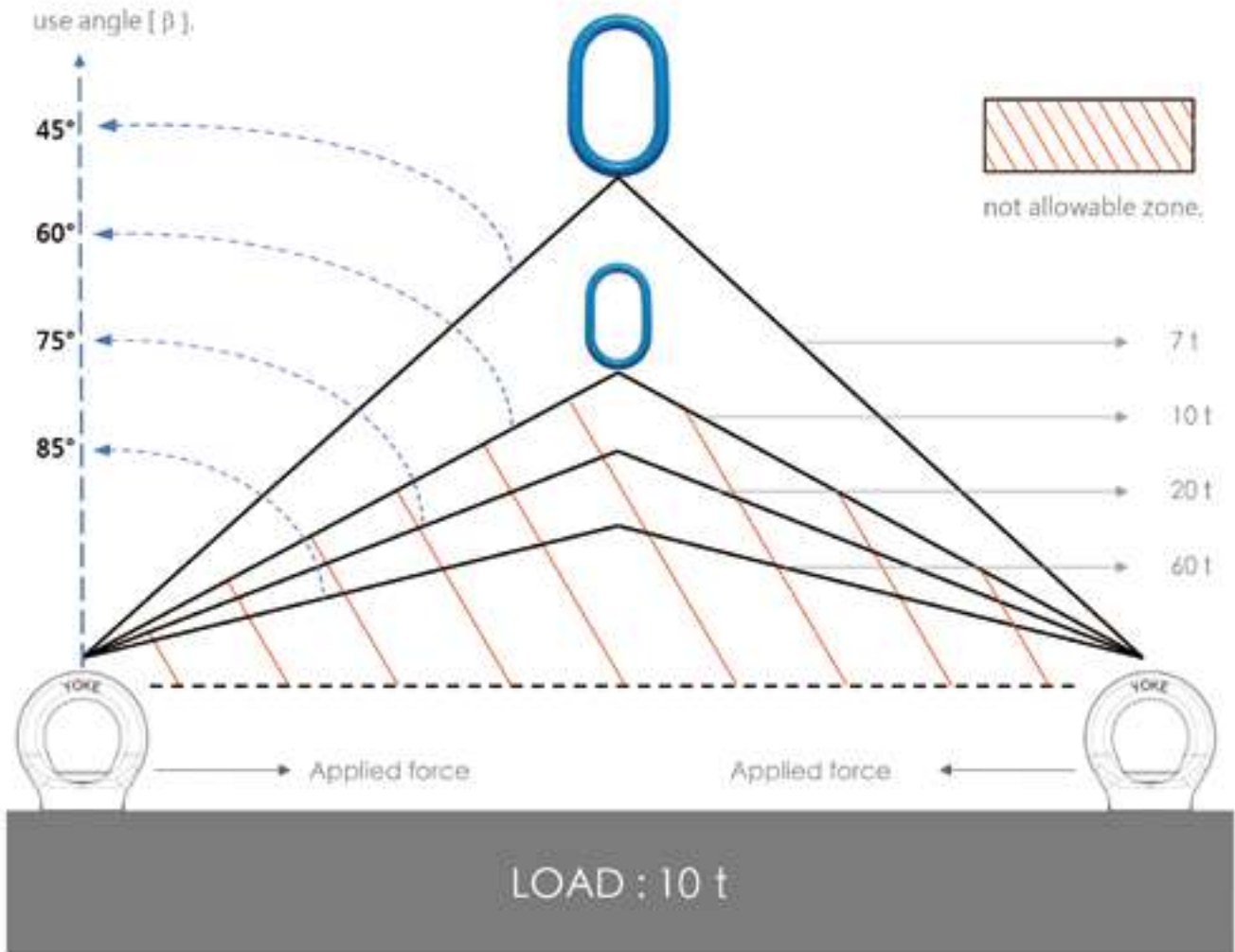

Tension in a single leg

The Tension load is also acting on the Yellow Points.

Quality Control, Testing, and Detecting during manufacturing

YOKE runs a constant and strict production facility with quality control in every manufacturing stage from raw materials to the completed product. YOKE is an ISO 9001 certified company and has Type Approval by the major international authorities from Deutsche Gesetzliche Unfallversicherung (DGUV) , ABS, API, and DNV. YOKE has achieved CNLA certification - Chinese National Laboratory Accreditation which ensures a quality research and development (R&D) department and unsurpassed product engineering.

■ Magnaflux Crack Detection:

All forged components are individually magnaflux detected after heat treatment.

■ Proof Load Testing:

YOKE Yellow Points are proof load qualified to 2.5 times the Working Load Limit within 1% permanent deformation.

■ Dynamic Fatigue Testing:

Batch samples of YOKE Yellow Points are Dynamic Fatigue Tested to 20,000 cycles at 1.5 times the Working Load Limit.

■ Ultimate Breaking Load Testing:

Batch samples are tested in a static tensile testing machine until failure. Minimum ultimate force equals to the Working Load Limit times safety factor.

■ Spectrographic Analysis:

To assure of the proper metallurgy content of all raw materials.



Test certificate
Complied to EN10204

Safety is our first priority™

- Quality, Reliability, Innovation -



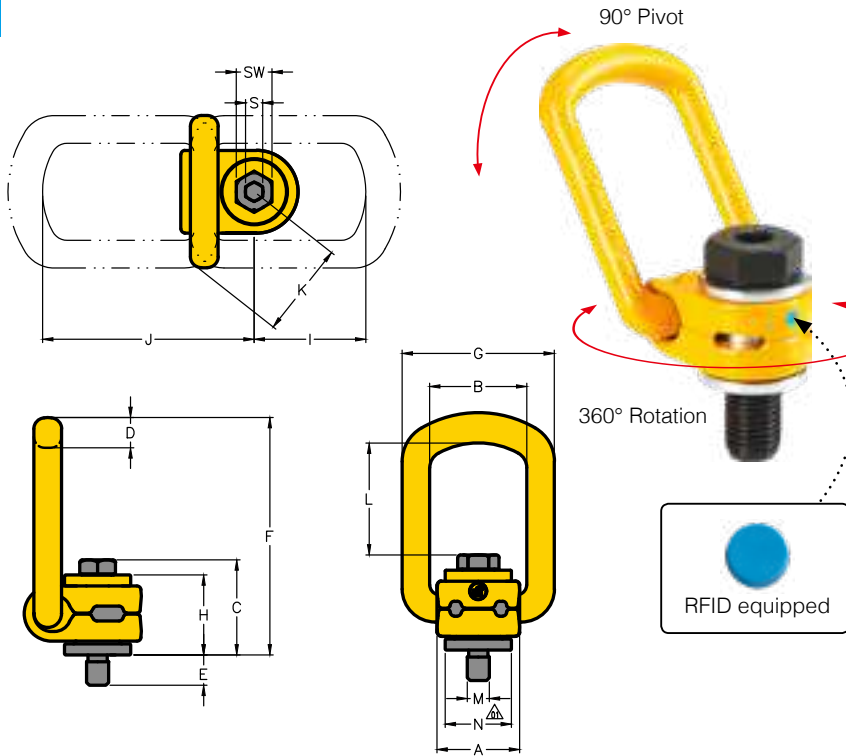

- Rotates through 360° and pivot 90°.
- Manufactured from alloy steel, quenched and tempered.
- Tested in accordance with EN1677-1.
- Certified by DGUV GS-OA 15-04.
- Load rated parts are 100% magnaflux crack detected.
- Individual forged parts and cap screw are traceable to Test Certification.
- Bolts are Metric thread.
- Proof tested to 2.5 times the WLL.
- Fatigue rated to 20,000 cycles at 1.5 times the WLL.
- All YOKE Lifting points meet or exceed all the requirements of ASME B30.26.
- Quick and simple assembly, just a tapped hole is required.

» Taiwan Patent
» China Patent

Lifting Point

Metric Thread (8-211)



| Item No. | Working Load Limit tonnes | Thread version | | | Dimensions | | | | | | | | | | | | | | Torque in Nm | N.W. kg |
|-----------|------------------------------|----------------|-----|-------|------------|-----|-----|----|-----|-----|----|----|----|-----|-----|-----|-----|----|--------------------|------------|
| | | M | E | Pitch | A | B | C | D | F | G | H | S | SW | I | J | K | L | N | | |
| | | mm | mm | DIN13 | mm | | | | | | | | | | | | | | | |
| 8-211-003 | 0.30 | M 8 | 11 | 1.25 | 30 | 35 | 35 | 11 | 86 | 55 | 29 | 6 | 13 | 41 | 77 | 34 | 41 | 24 | 30 | 0.3 |
| 8-211-006 | 0.63 | M 10 | 16 | 1.50 | 30 | 35 | 36 | 11 | 86 | 55 | 29 | 6 | 17 | 42 | 78 | 34 | 40 | 24 | 60 | 0.4 |
| 8-211-010 | 1.00 | M 12 | 18 | 1.75 | 33 | 38 | 44 | 14 | 99 | 57 | 36 | 8 | 19 | 44 | 89 | 38 | 42 | 31 | 100 | 0.5 |
| 8-211-012 | 1.20 | M 14 | 21 | 2.00 | 33 | 38 | 45 | 14 | 99 | 57 | 36 | 10 | 22 | 45 | 89 | 38 | 40 | 31 | 120 | 0.5 |
| 8-211-015 | 1.50 | M 16 | 24 | 2.00 | 33 | 38 | 46 | 14 | 99 | 57 | 36 | 10 | 24 | 45 | 89 | 38 | 40 | 31 | 150 | 0.6 |
| 8-211-020 | 2.00 | M 18 | 26 | 2.50 | 50 | 54 | 57 | 16 | 143 | 82 | 44 | 12 | 30 | 74 | 132 | 52 | 70 | 45 | 200 | 1.3 |
| 8-211-025 | 2.50 | M 20 | 31 | 2.50 | 50 | 54 | 56 | 16 | 142 | 82 | 43 | 12 | 30 | 74 | 132 | 53 | 70 | 49 | 250 | 1.6 |
| 8-211-040 | 4.00 | M 24 | 36 | 3.00 | 50 | 54 | 59 | 16 | 143 | 82 | 44 | 14 | 36 | 74 | 132 | 53 | 67 | 45 | 400 | 1.9 |
| 8-211-042 | 4.00 | M 27 | 38 | 3.00 | 60 | 65 | 79 | 23 | 171 | 99 | 62 | 17 | 41 | 81 | 152 | 64 | 69 | 59 | 400 | 2.9 |
| 8-211-050 | 5.00 | M 30 | 49 | 3.50 | 60 | 65 | 81 | 23 | 170 | 99 | 62 | 17 | 46 | 80 | 153 | 64 | 67 | 59 | 500 | 3.1 |
| 8-211-070 | 7.00 | M 36 | 56 | 4.00 | 60 | 65 | 75 | 23 | 171 | 99 | 58 | 22 | 55 | 80 | 153 | 64 | 74 | 59 | 700 | 3.1 |
| 8-211-080 | 8.00 | M 36 | 62 | 4.00 | 77 | 85 | 101 | 27 | 225 | 124 | 78 | 22 | 55 | 112 | 205 | 80 | 97 | 69 | 800 | 5.9 |
| 8-211-100 | 10.00 | M 42 | 72 | 4.50 | 77 | 85 | 104 | 27 | 225 | 124 | 78 | 24 | 65 | 113 | 204 | 79 | 94 | 69 | 1000 | 6.3 |
| 8-211-150 | 15.00 | M 42 | 64 | 4.50 | 95 | 104 | 112 | 36 | 258 | 158 | 86 | 24 | 65 | 127 | 229 | 98 | 110 | 98 | 1500 | 10.9 |
| 8-211-200 | 20.00 | M 48 | 73 | 5.00 | 95 | 104 | 120 | 36 | 260 | 158 | 90 | 27 | 75 | 126 | 230 | 99 | 104 | 98 | 2000 | 12.1 |
| 8-211-220 | 22.00 | M56 | 85 | 5.50 | 95 | 104 | 121 | 36 | 261 | 158 | 91 | 27 | 85 | 125 | 231 | 99 | 104 | 98 | 2100 | 13.1 |
| 8-211-225 | 22.50 | M64 | 100 | 6.00 | 113 | 104 | 126 | 36 | 261 | 158 | 91 | 32 | 95 | 121 | 235 | 101 | 99 | 98 | 2200 | 15.5 |

* Design Factor 4:1
* Bolt in GEOMET[®] finished on request



| Kind of attachment | | | | | | | | | | | | | | | | |
|--------------------|--------|--------|-------|-------|-------|-----------|---------|---------|---------|-----------|---------|---------|---------|---------|---------|--|
| | 1 | 2 | 1 | 2 | 2 | 2 | 2 | 2 | 3-4 | 3-4 | 3-4 | 3-4 | 3-4 | 3-4 | 3-4 | |
| Number of legs | 1 | 2 | 1 | 2 | 2 | 2 | 2 | 2 | 3-4 | 3-4 | 3-4 | 3-4 | 3-4 | 3-4 | 3-4 | |
| Load direction | 0° | 0° | 90° | 90° | 0-45° | 45° - 60° | unsymm. | unsymm. | 0 - 45° | 45° - 60° | unsymm. | unsymm. | unsymm. | unsymm. | unsymm. | |
| Item No. | Thread | WLL(t) | | | | | | | | | | | | | | |
| 8-211-003 | M 8 | 0.30 | 0.60 | 0.30 | 0.60 | 0.42 | 0.30 | 0.30 | 0.63 | 0.45 | 0.30 | 0.63 | 0.45 | 0.30 | | |
| 8-211-006 | M 10 | 0.63 | 1.26 | 0.63 | 1.26 | 0.88 | 0.63 | 0.63 | 1.32 | 0.95 | 0.63 | 1.32 | 0.95 | 0.63 | | |
| 8-211-010 | M 12 | 1.00 | 2.00 | 1.00 | 2.00 | 1.40 | 1.00 | 1.00 | 2.10 | 1.50 | 1.00 | 2.10 | 1.50 | 1.00 | | |
| 8-211-012 | M 14 | 1.20 | 2.40 | 1.20 | 2.40 | 1.70 | 1.20 | 1.20 | 2.50 | 1.80 | 1.20 | 2.50 | 1.80 | 1.20 | | |
| 8-211-015 | M 16 | 1.50 | 3.00 | 1.50 | 3.00 | 2.10 | 1.50 | 1.50 | 3.10 | 2.20 | 1.50 | 3.10 | 2.20 | 1.50 | | |
| 8-211-020 | M 18 | 2.00 | 4.00 | 2.00 | 4.00 | 2.80 | 2.00 | 2.00 | 4.20 | 3.00 | 2.00 | 4.20 | 3.00 | 2.00 | | |
| 8-211-025 | M 20 | 2.50 | 5.00 | 2.50 | 5.00 | 3.50 | 2.50 | 2.50 | 5.20 | 3.70 | 2.50 | 5.20 | 3.70 | 2.50 | | |
| 8-211-040 | M 24 | 4.00 | 8.00 | 4.00 | 8.00 | 5.60 | 4.00 | 4.00 | 8.40 | 6.00 | 4.00 | 8.40 | 6.00 | 4.00 | | |
| 8-211-042 | M 27 | 4.00 | 8.00 | 4.00 | 8.00 | 5.60 | 4.00 | 4.00 | 8.40 | 6.00 | 4.00 | 8.40 | 6.00 | 4.00 | | |
| 8-211-050 | M 30 | 5.00 | 10.00 | 5.00 | 10.00 | 7.00 | 5.00 | 5.00 | 10.50 | 7.50 | 5.00 | 10.50 | 7.50 | 5.00 | | |
| 8-211-070 | M 36 | 7.00 | 14.00 | 7.00 | 14.00 | 9.80 | 7.00 | 7.00 | 14.70 | 10.5 | 7.00 | 14.70 | 10.5 | 7.00 | | |
| 8-211-080 | M 36 | 8.00 | 16.00 | 8.00 | 16.00 | 11.20 | 8.00 | 8.00 | 16.80 | 12.00 | 8.00 | 16.80 | 12.00 | 8.00 | | |
| 8-211-100 | M 42 | 10.00 | 20.00 | 10.00 | 20.00 | 14.00 | 10.00 | 10.00 | 21.00 | 15.00 | 10.00 | 21.00 | 15.00 | 10.00 | | |
| 8-211-150 | M 42 | 15.00 | 30.00 | 15.00 | 30.00 | 21.00 | 15.00 | 15.00 | 31.50 | 22.50 | 15.00 | 31.50 | 22.50 | 15.00 | | |
| 8-211-200 | M 48 | 20.00 | 40.00 | 20.00 | 40.00 | 28.00 | 20.00 | 20.00 | 42.00 | 30.00 | 20.00 | 42.00 | 30.00 | 20.00 | | |
| 8-211-220 | M 56 | 22.00 | 44.00 | 22.00 | 44.00 | 30.80 | 22.00 | 22.00 | 46.20 | 33.00 | 22.00 | 46.20 | 33.00 | 22.00 | | |
| 8-211-225 | M 64 | 22.50 | 45.00 | 22.50 | 45.00 | 31.50 | 22.50 | 22.50 | 47.25 | 33.75 | 22.50 | 47.25 | 33.75 | 22.50 | | |

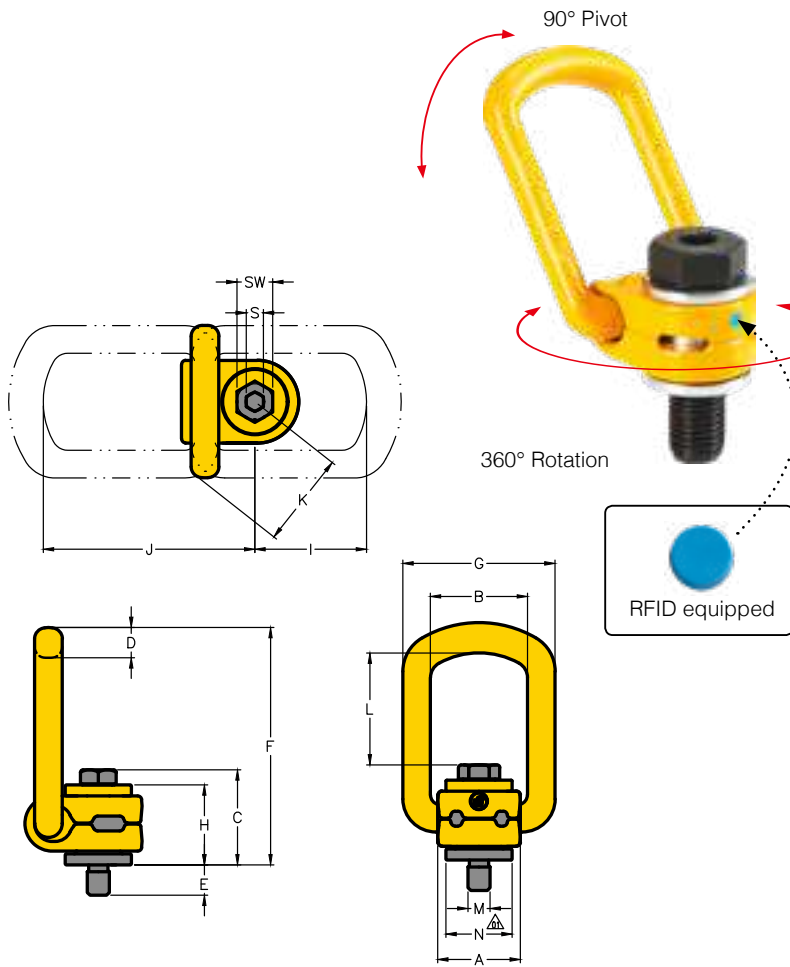

- Rotates through 360° and pivots 90°.
- Manufactured from alloy steel, quenched and tempered.
- Tested in accordance with EN1677-1.
- Load rated parts are 100% magnaflux crack detected.
- Individual forged parts and cap screw are traceable to Test Certification.
- Bolts are UNC thread.
- Proof tested to 2.5 times the WLL.
- Fatigue rated to 20,000 cycles at 1.5 times the WLL.
- All YOKE Lifting points meet or exceed all the requirements of ASME B30.26.
- Quick and simple assembly, just a tapped hole is required.

» Taiwan Patent
» China Patent

Lifting Point

UNC Thread (8-212)



| Item No. | Working Load Limit | Thread version | | | Dimensions | | | | | | | | | | | | | Torque | | |
|-----------|--------------------|----------------|------|---------|------------|------|------|------|-------|------|------|-------|--------|------|------|------|------|--------|------|------|
| | | M | E | TPI | A | B | C | D | F | G | H | S | SW | I | J | K | L | N | in | N.W. |
| | tonnes | inch | inch | | mm | | | | | | | | | | | | | Nm | lbs | |
| 8-212-010 | 1.0 | 1/2 | 0.94 | 13.0UNC | 1.30 | 1.48 | 1.73 | 0.53 | 3.90 | 2.24 | 1.42 | 5/16 | 3/4 | 1.74 | 3.49 | 1.49 | 1.62 | 1.22 | 100 | 1 |
| 8-212-015 | 1.5 | 5/8 | 1.14 | 11.0UNC | 1.30 | 1.48 | 1.81 | 0.53 | 3.90 | 2.24 | 1.42 | 3/8 | 15/16 | 1.76 | 3.49 | 1.47 | 1.56 | 1.22 | 150 | 1.3 |
| 8-212-020 | 2.5 | 3/4 | 1.46 | 10.0UNC | 1.97 | 2.12 | 2.16 | 0.65 | 5.58 | 3.22 | 1.69 | 1/2 | 1 1/8 | 2.90 | 5.23 | 2.07 | 2.77 | 1.93 | 200 | 2.9 |
| 8-212-025 | 2.5 | 7/8 | 1.46 | 9.0UNC | 1.97 | 2.12 | 2.24 | 0.65 | 5.58 | 3.22 | 1.69 | 5/8 | 1 5/16 | 2.90 | 5.23 | 2.07 | 2.69 | 1.93 | 250 | 2.8 |
| 8-212-040 | 4.0 | 1 | 1.61 | 8.0UNC | 1.91 | 2.13 | 2.34 | 0.65 | 5.62 | 3.22 | 1.73 | 5/8 | 1 1/2 | 2.87 | 5.26 | 2.09 | 2.63 | 1.77 | 400 | 4.3 |
| 8-212-050 | 5.0 | 1 1/4 | 2.11 | 7.0UNC | 2.36 | 2.56 | 3.21 | 0.89 | 6.70 | 3.90 | 2.42 | 7/8 | 1 7/8 | 3.14 | 6.00 | 2.53 | 2.60 | 2.32 | 500 | 6.8 |
| 8-212-080 | 8.0 | 1 1/2 | 2.44 | 6.0UNC | 3.03 | 3.35 | 4.01 | 1.04 | 8.85 | 4.88 | 3.07 | 1 | 2 1/4 | 4.42 | 8.04 | 3.15 | 3.80 | 2.72 | 800 | 12.9 |
| 8-212-150 | 15.0 | 1 3/4 | 2.60 | 5.0UNC | 3.74 | 4.09 | 4.41 | 1.42 | 10.16 | 6.22 | 3.39 | 1 | 2 5/8 | 5.00 | 9.01 | 3.85 | 4.33 | 3.86 | 1500 | 24.5 |
| 8-212-200 | 20.0 | 2 | 2.80 | 4.5UNC | 3.74 | 4.09 | 4.72 | 1.42 | 10.24 | 6.22 | 3.54 | 1 1/4 | 3 | 4.94 | 9.07 | 3.88 | 4.09 | 3.86 | 2000 | 27.2 |

* Design Factor 4:1
* Bolt in GEOMET® finished on request



| Kind of attachment | | | | | | | | | | | |
|--------------------|----------------|--------|----|------|-----|-------|-----------|---------|---------|-----------|---------|
| Number of legs | Load direction | 1 | 2 | 1 | 2 | 2 | 2 | 2 | 3-4 | 3-4 | 3-4 |
| Item No. | Thread | 0° | 0° | 90° | 90° | 0-45° | 45° - 60° | unsymm. | 0 - 45° | 45° - 60° | unsymm. |
| | | WLL(t) | | | | | | | | | |
| 8-212-010 | 1/2 | 1.0 | 2 | 1.0 | 2 | 1.4 | 1.0 | 1.0 | 2.1 | 1.5 | 1.0 |
| 8-212-015 | 5/8 | 1.5 | 3 | 1.5 | 3 | 2.1 | 1.5 | 1.5 | 3.1 | 2.2 | 1.5 |
| 8-212-020 | 3/4 | 2.5 | 5 | 2.5 | 5 | 3.5 | 2.5 | 2.5 | 5.2 | 3.7 | 2.5 |
| 8-212-025 | 7/8 | 2.5 | 5 | 2.5 | 5 | 3.5 | 2.5 | 2.5 | 5.2 | 3.7 | 2.5 |
| 8-212-040 | 1 | 4.0 | 8 | 4.0 | 8 | 5.6 | 4.0 | 4.0 | 8.4 | 6.0 | 4.0 |
| 8-212-050 | 1 1/4 | 5.0 | 10 | 5.0 | 10 | 7.0 | 5.0 | 5.0 | 10.5 | 7.5 | 5.0 |
| 8-212-080 | 1 1/2 | 8.0 | 16 | 8.0 | 16 | 11.2 | 8.0 | 8.0 | 16.8 | 12.0 | 8.0 |
| 8-212-150 | 1 3/4 | 15.0 | 30 | 15.0 | 30 | 21.0 | 15.0 | 15.0 | 31.5 | 22.5 | 15.0 |
| 8-212-200 | 2 | 20.0 | 40 | 20.0 | 40 | 28.0 | 20.0 | 20.0 | 42.0 | 30.0 | 20.0 |

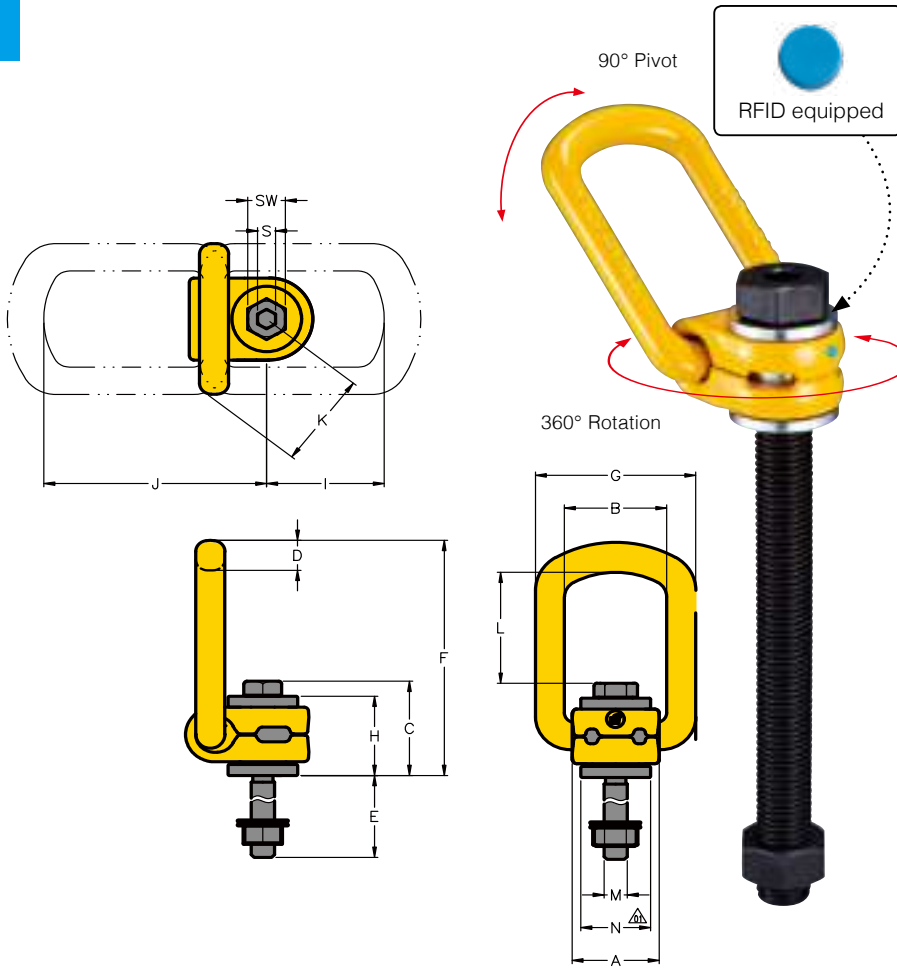

- Rotates through 360° and pivots 90°.
- Manufactured from alloy steel, quenched and tempered.
- Tested in accordance with EN1677-1.
- Load rated parts are 100% magnaflux crack detected.
- Individual forged parts and cap screw are traceable to Test Certification.
- Bolts are Metric thread.
- Proof tested to 2.5 times the WLL.
- Fatigue rated to 20,000 cycles at 1.5 times the WLL.
- All YOKE Lifting points meet or exceed all the requirements of ASME B30.26.
- Quick and simple assembly, just a tapped hole is required.

» Taiwan Patent
» China Patent

Lifting Point Long Bolt

Metric Thread (8-211L)



| Item No. | Working Load Limit | Thread version | | | Dimensions | | | | | | | | | | | | | | Torque in Nm | N.W. kg |
|----------------|--------------------|----------------|-----|-------|------------|-----|-----|----|-----|-----|----|----|----|-----|-----|----|-----|----|--------------|---------|
| | | M | E | Pitch | A | B | C | D | F | G | H | S | SW | I | J | K | L | N | | |
| | tonnes | mm | mm | DIN13 | mm | | | | | | | | | | | | | | | |
| 8-211-003/105L | 0.30 | M 8 | 76 | 1.25 | 30 | 35 | 35 | 11 | 86 | 55 | 29 | 6 | 13 | 41 | 77 | 34 | 41 | 24 | 30 | 0.4 |
| 8-211-006/125L | 0.63 | M 10 | 96 | 1.50 | 30 | 35 | 36 | 11 | 86 | 55 | 29 | 6 | 17 | 42 | 78 | 34 | 40 | 24 | 60 | 0.4 |
| 8-211-010/150L | 1.00 | M 12 | 114 | 1.75 | 33 | 38 | 44 | 14 | 99 | 57 | 36 | 8 | 19 | 44 | 89 | 38 | 42 | 31 | 100 | 0.5 |
| 8-211-015/185L | 1.50 | M 16 | 149 | 2.00 | 33 | 38 | 46 | 14 | 99 | 57 | 36 | 10 | 24 | 45 | 89 | 38 | 40 | 31 | 150 | 0.7 |
| 8-211-025/230L | 2.50 | M 20 | 187 | 2.50 | 50 | 54 | 56 | 16 | 142 | 82 | 43 | 12 | 30 | 74 | 132 | 53 | 70 | 49 | 250 | 1.7 |
| 8-211-040/265L | 4.00 | M 24 | 221 | 3.00 | 50 | 54 | 59 | 16 | 143 | 82 | 44 | 14 | 36 | 74 | 132 | 53 | 67 | 45 | 400 | 2.0 |
| 8-211-050/340L | 5.00 | M 30 | 279 | 3.50 | 60 | 65 | 81 | 23 | 170 | 99 | 62 | 17 | 46 | 80 | 153 | 64 | 67 | 59 | 500 | 2.9 |
| 8-211-080/300L | 8.00 | M 36 | 222 | 4.00 | 77 | 85 | 101 | 27 | 225 | 124 | 78 | 22 | 55 | 112 | 205 | 80 | 97 | 69 | 800 | 6.9 |
| 8-211-100/350L | 10.00 | M 42 | 272 | 4.50 | 77 | 85 | 104 | 27 | 225 | 124 | 78 | 24 | 65 | 113 | 204 | 79 | 94 | 69 | 1000 | 7.9 |
| 8-211-150/350L | 15.00 | M 42 | 264 | 4.50 | 95 | 104 | 112 | 36 | 258 | 158 | 86 | 24 | 65 | 127 | 229 | 98 | 110 | 98 | 1500 | 13.5 |
| 8-211-200/385L | 20.00 | M 48 | 295 | 5.00 | 95 | 104 | 120 | 36 | 260 | 158 | 90 | 27 | 75 | 126 | 230 | 99 | 104 | 98 | 2000 | 15.5 |

* Design Factor 4:1
* Bolt in GEOMET[®] finished on request



| Kind of attachment | | | | | | | | | | | |
|--------------------|----------------|--------|-------|-------|-------|-------|-----------|---------|---------|-----------|---------|
| Number of legs | Load direction | 1 | 2 | 1 | 2 | 2 | 2 | 2 | 3-4 | 3-4 | 3-4 |
| Item No. | Thread | 0° | 0° | 90° | 90° | 0-45° | 45° - 60° | unsymm. | 0 - 45° | 45° - 60° | unsymm. |
| | | WLL(t) | | | | | | | | | |
| 8-211-003/105L | M 8 | 0.30 | 0.60 | 0.30 | 0.60 | 0.42 | 0.30 | 0.30 | 0.63 | 0.45 | 0.30 |
| 8-211-006/125L | M10 | 0.63 | 1.26 | 0.63 | 1.26 | 0.88 | 0.63 | 0.63 | 1.32 | 0.95 | 0.63 |
| 8-211-010/150L | M12 | 1.00 | 2.00 | 1.00 | 2.00 | 1.40 | 1.00 | 1.00 | 2.10 | 1.50 | 1.00 |
| 8-211-015/185L | M16 | 1.50 | 3.00 | 1.50 | 3.00 | 2.10 | 1.50 | 1.50 | 3.10 | 2.20 | 1.50 |
| 8-211-025/230L | M20 | 2.50 | 5.00 | 2.50 | 5.00 | 3.50 | 2.50 | 2.50 | 5.20 | 3.70 | 2.50 |
| 8-211-040/265L | M24 | 4.00 | 8.00 | 4.00 | 8.00 | 5.60 | 4.00 | 4.00 | 8.40 | 6.00 | 4.00 |
| 8-211-050/340L | M30 | 5.00 | 10.00 | 5.00 | 10.00 | 7.00 | 5.00 | 5.00 | 10.50 | 7.50 | 5.00 |
| 8-211-080/300L | M36 | 8.00 | 16.00 | 8.00 | 16.00 | 11.20 | 8.00 | 8.00 | 16.80 | 12.00 | 8.00 |
| 8-211-100/350L | M42 | 10.00 | 20.00 | 10.00 | 20.00 | 14.00 | 10.00 | 10.00 | 21.00 | 15.00 | 10.00 |
| 8-211-150/350L | M42 | 15.00 | 30.00 | 15.00 | 30.00 | 21.00 | 15.00 | 15.00 | 31.50 | 22.50 | 15.00 |
| 8-211-200/385L | M48 | 20.00 | 40.00 | 20.00 | 40.00 | 28.00 | 20.00 | 20.00 | 42.00 | 30.00 | 20.00 |

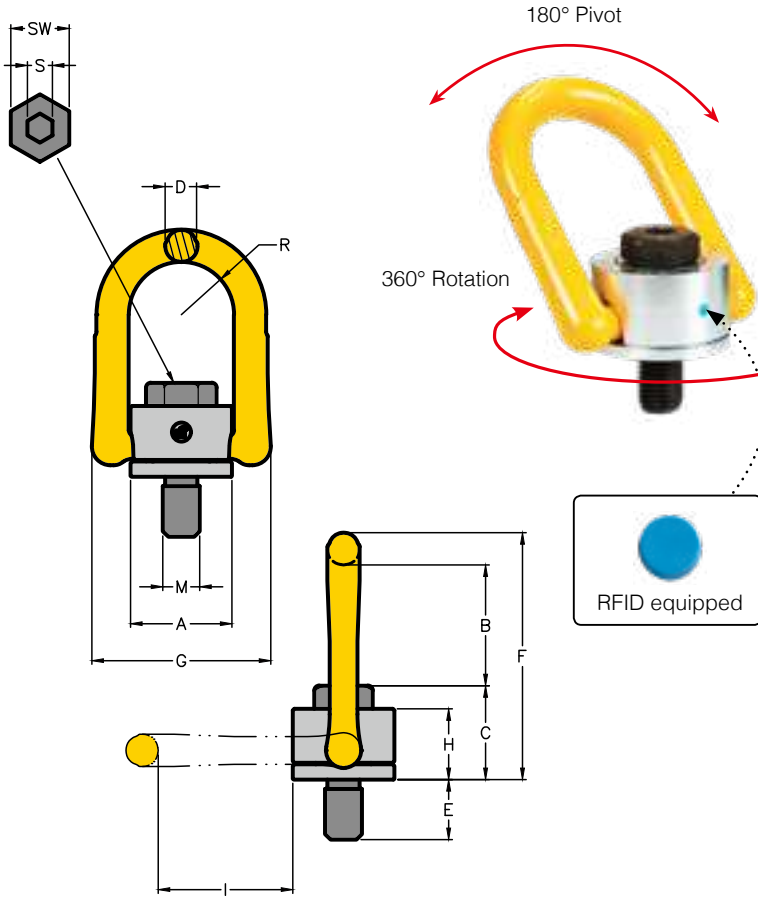

- Rotates through 360° and pivots 180°, and simultaneously allows lifting from any direction.
- Manufactured from forged alloy steel, quenched and tempered.
- Tested in accordance with EN1677-1.
- Load rated parts are 100% magnaflux crack detected.
- Individual forged parts and cap screw are traceable to Test Certification.
- Bolts are Metric thread.
- Proof tested to 2.5 times the WLL.
- Fatigue rated to 20,000 cycles at 1.5 times the WLL.
- All YOKE Lifting points meet or exceed all the requirements of ASME B30.26.
- Quick and simple assembly, just a tapped hole is required.

» Taiwan Patent
» China Patent

Anchor Point

Metric Thread (8-231)



| Item No. | Working Load Limit | Thread version | | | Dimensions | | | | | | | | | | Torque in | N.W. | |
|-----------|--------------------|----------------|-----|-------|------------|-----|-----|----|-----|-----|----|----|----|----|-----------|------|------|
| | | M | E | Pitch | A | B | C | D | F | G | H | R | S | SW | | | I |
| | tonnes | mm | mm | DIN13 | mm | | | | | | | | | | Nm | kg | |
| 8-231-005 | 0.5 | M 8 | 13 | 1.25 | 33 | 42 | 28 | 11 | 80 | 58 | 23 | 17 | 6 | 13 | 44 | 30 | 0.3 |
| 8-231-007 | 0.7 | M 10 | 16 | 1.50 | 33 | 41 | 29 | 11 | 80 | 58 | 23 | 17 | 6 | 17 | 44 | 60 | 0.3 |
| 8-231-010 | 1.0 | M 12 | 20 | 1.75 | 33 | 39 | 31 | 11 | 80 | 58 | 23 | 17 | 8 | 19 | 44 | 100 | 0.3 |
| 8-231-015 | 1.5 | M 14 | 21 | 2.00 | 51 | 56 | 45 | 17 | 116 | 90 | 36 | 27 | 10 | 22 | 63 | 120 | 0.9 |
| 8-231-020 | 2.0 | M 16 | 24 | 2.00 | 50 | 54 | 46 | 17 | 116 | 90 | 36 | 27 | 10 | 24 | 63 | 150 | 0.9 |
| 8-231-025 | 2.5 | M 18 | 26 | 2.50 | 65 | 77 | 57 | 20 | 155 | 108 | 44 | 34 | 12 | 30 | 86 | 200 | 1.9 |
| 8-231-030 | 3.0 | M 20 | 34 | 2.50 | 51 | 52 | 49 | 17 | 116 | 90 | 37 | 27 | 12 | 30 | 63 | 250 | 1.0 |
| 8-231-050 | 5.0 | M 24 | 36 | 3.00 | 72 | 81 | 59 | 25 | 163 | 125 | 45 | 37 | 14 | 36 | 88 | 400 | 2.6 |
| 8-231-056 | 5.6 | M 27 | 38 | 3.00 | 87 | 96 | 79 | 30 | 204 | 148 | 62 | 46 | 17 | 41 | 110 | 400 | 4.9 |
| 8-231-078 | 7.8 | M 30 | 48 | 3.50 | 87 | 94 | 81 | 30 | 204 | 148 | 62 | 46 | 17 | 46 | 110 | 500 | 5.0 |
| 8-231-125 | 12.5 | M 36 | 56 | 4.00 | 109 | 112 | 98 | 36 | 248 | 188 | 75 | 57 | 22 | 55 | 128 | 1000 | 9.6 |
| 8-231-156 | 15.6 | M 42 | 64 | 4.50 | 110 | 101 | 108 | 36 | 248 | 188 | 82 | 57 | 24 | 65 | 128 | 1500 | 10.9 |
| 8-231-200 | 20.0 | M 48 | 73 | 5.00 | 110 | 97 | 112 | 36 | 248 | 188 | 82 | 57 | 27 | 75 | 128 | 2000 | 11.6 |
| 8-231-220 | 22.0 | M 56 | 85 | 5.50 | 123 | 116 | 121 | 36 | 274 | 202 | 91 | 64 | 27 | 85 | 145 | 2100 | 15.0 |
| 8-231-225 | 22.5 | M 64 | 100 | 6.00 | 123 | 111 | 126 | 36 | 274 | 202 | 91 | 64 | 32 | 95 | 146 | 2200 | 16.3 |

* Design Factor 4:1



| Kind of attachment | | | | | | | | | | | |
|--------------------|----------------|--------|------|------|------|-------|-----------|---------|---------|-----------|---------|
| Number of legs | Load direction | 1 | 2 | 1 | 2 | 2 | 2 | 2 | 3-4 | 3-4 | 3-4 |
| Item No. | Thread | 0° | 0° | 90° | 90° | 0-45° | 45° - 60° | unsymm. | 0 - 45° | 45° - 60° | unsymm. |
| | | WLL(t) | | | | | | | | | |
| 8-231-005 | M 8 | 0.8 | 1.6 | 0.5 | 1.0 | 0.7 | 0.5 | 0.5 | 1.10 | 0.80 | 0.5 |
| 8-231-007 | M 10 | 1.2 | 2.4 | 0.7 | 1.4 | 1.0 | 0.7 | 0.7 | 1.50 | 1.10 | 0.7 |
| 8-231-010 | M 12 | 1.5 | 3.0 | 1.0 | 2.0 | 1.4 | 1.0 | 1.0 | 2.10 | 1.50 | 1.0 |
| 8-231-015 | M 14 | 2.4 | 4.8 | 1.5 | 3.0 | 2.1 | 1.5 | 1.5 | 3.20 | 2.30 | 1.5 |
| 8-231-020 | M 16 | 3.2 | 6.4 | 2.0 | 4.0 | 2.8 | 2.0 | 2.0 | 4.20 | 3.00 | 2.0 |
| 8-231-025 | M 18 | 5.0 | 10.0 | 2.5 | 5.0 | 3.5 | 2.5 | 2.5 | 5.30 | 3.80 | 2.5 |
| 8-231-030 | M 20 | 4.5 | 9.0 | 3.0 | 6.0 | 4.2 | 3.0 | 3.0 | 6.30 | 4.50 | 3.0 |
| 8-231-050 | M 24 | 9.0 | 18.0 | 5.0 | 10.0 | 7.0 | 5.0 | 5.0 | 10.50 | 7.50 | 5.0 |
| 8-231-056 | M 27 | 9.5 | 19.0 | 5.6 | 11.2 | 7.8 | 5.6 | 5.6 | 11.80 | 8.40 | 5.6 |
| 8-231-078 | M 30 | 12.0 | 24.0 | 7.8 | 15.6 | 10.9 | 7.8 | 7.8 | 16.40 | 11.70 | 7.8 |
| 8-231-125 | M 36 | 14.0 | 28.0 | 12.5 | 25.0 | 17.5 | 12.5 | 12.5 | 26.30 | 18.80 | 12.5 |
| 8-231-156 | M 42 | 16.0 | 32.0 | 15.6 | 31.2 | 21.8 | 15.6 | 15.6 | 32.80 | 23.40 | 15.6 |
| 8-231-200 | M 48 | 20.0 | 40.0 | 20.0 | 40.0 | 28.0 | 20.0 | 20.0 | 42.00 | 30.00 | 20.0 |
| 8-231-220 | M 56 | 22.0 | 44.0 | 22.0 | 44.0 | 30.8 | 22.0 | 22.0 | 46.20 | 33.00 | 22.0 |
| 8-231-225 | M 64 | 22.5 | 45.0 | 22.5 | 45.0 | 31.5 | 22.5 | 22.5 | 47.25 | 33.75 | 22.5 |

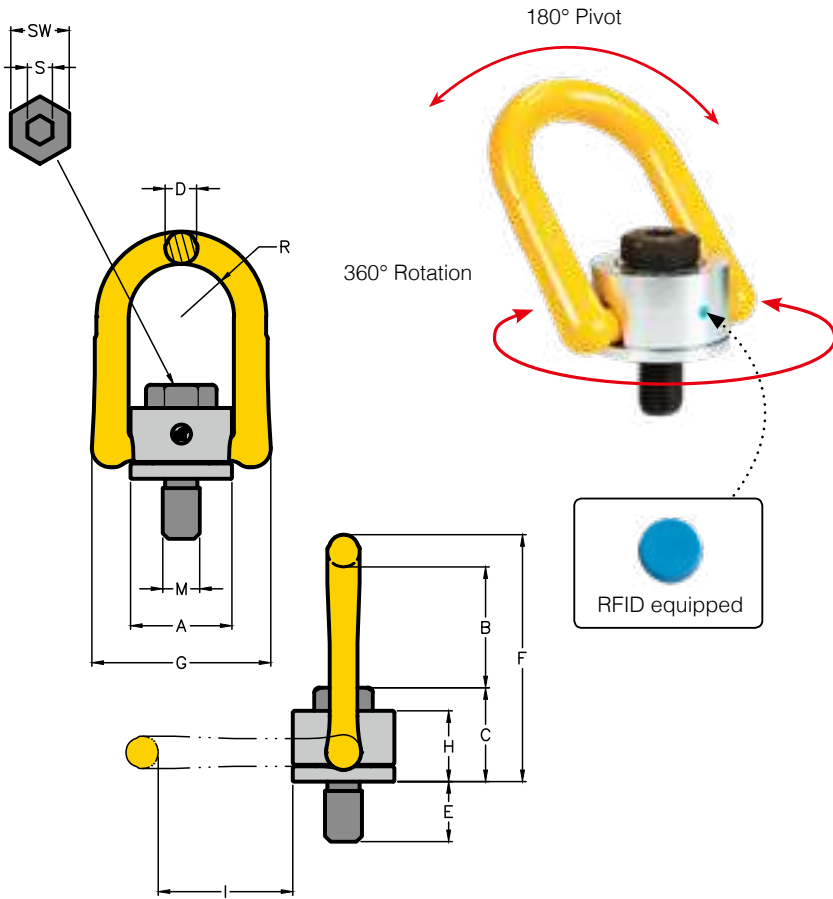

- Rotates through 360° and pivots 180°, and simultaneously allows lifting from any direction.
- Manufactured from forged alloy steel, quenched and tempered.
- Tested in accordance with EN1677-1.
- Load rated parts are 100% magnaflux crack detected.
- Individual forged parts and cap screw are traceable to Test Certification.
- Bolts are UNC thread.
- Proof tested to 2.5 times the WLL.
- Fatigue rated to 20,000 cycles at 1.5 times the WLL.
- All YOKE Lifting points meet or exceed all the requirements of ASME B30.26.
- Quick and simple assembly, just a tapped hole is required.

» Taiwan Patent
» China Patent

Anchor Point

UNC Thread (8-232)



| Item No. | Working Load Limit | Thread version | | | Dimensions | | | | | | | | | | Torque in | N.W. | |
|-----------|--------------------|----------------|------|---------|------------|------|------|------|------|------|------|------|-------|--------|-----------|------|------|
| | | M | E | TPI | A | B | C | D | F | G | H | R | S | SW | | | I |
| | tonnes | inch | inch | | inch | | | | | | | | | | Nm | lbs | |
| 8-232-010 | 0.80 | 1/2 | 0.81 | 13 UNC | 1.30 | 1.55 | 1.20 | 0.41 | 3.16 | 2.29 | 0.91 | 0.67 | 5/16 | 3/4 | 1.72 | 100 | 0.6 |
| 8-232-020 | 1.60 | 5/8 | 1.14 | 11 UNC | 1.97 | 2.14 | 1.81 | 0.65 | 4.56 | 3.54 | 1.42 | 1.06 | 3/8 | 15/16 | 2.48 | 150 | 2.0 |
| 8-232-030 | 2.40 | 3/4 | 1.54 | 10 UNC | 2.01 | 2.06 | 1.89 | 0.65 | 4.56 | 3.54 | 1.44 | 1.06 | 1/2 | 1 1/8 | 2.46 | 250 | 2.1 |
| 8-232-038 | 3.00 | 7/8 | 1.42 | 9 UNC | 2.81 | 3.24 | 2.28 | 0.98 | 6.42 | 4.94 | 1.75 | 1.47 | 5/8 | 1 5/16 | 3.45 | 300 | 5.0 |
| 8-232-050 | 4.00 | 1 | 1.61 | 8 UNC | 2.81 | 3.18 | 2.34 | 0.98 | 6.42 | 4.94 | 1.75 | 1.47 | 5/8 | 1 1/2 | 3.45 | 400 | 3.4 |
| 8-232-078 | 6.25 | 1 1/4 | 2.09 | 7 UNC | 3.43 | 3.65 | 3.23 | 1.16 | 8.02 | 5.82 | 2.44 | 1.79 | 7/8 | 1 7/8 | 4.31 | 500 | 11.2 |
| 8-232-125 | 10.00 | 1 1/2 | 2.40 | 6 UNC | 4.29 | 4.38 | 4.05 | 1.42 | 9.92 | 7.40 | 3.11 | 2.22 | 1 | 2 1/4 | 5.04 | 800 | 22.3 |
| 8-232-200 | 16.00 | 2 | 2.99 | 4.5 UNC | 4.61 | 3.84 | 4.53 | 1.42 | 9.93 | 7.71 | 3.35 | 2.38 | 1 1/4 | 3 | 4.88 | 2000 | 28.7 |

* Design Factor 5:1



| Kind of attachment | | | | | | | | | | | | | | | | | | |
|--------------------|----------------|----------------|------|-------|------|-------|-------|-------|-------|-------|-------|-----|-----|-----|-----|-----|-----|-----|
| | Number of legs | Load direction | 1 | 2 | 1 | 2 | 2 | 2 | 2 | 3-4 | 3-4 | 3-4 | 3-4 | 3-4 | 3-4 | 3-4 | 3-4 | 3-4 |
| Item No. | Thread | WLL(t) | | | | | | | | | | | | | | | | |
| 8-232-010 | 1/2 | 1.2 | 2.4 | 0.80 | 1.6 | 1.12 | 0.80 | 0.80 | 1.68 | 1.20 | 0.80 | | | | | | | |
| 8-232-020 | 5/8 | 2.6 | 5.2 | 1.60 | 3.2 | 2.24 | 1.60 | 1.60 | 3.36 | 2.40 | 1.60 | | | | | | | |
| 8-232-030 | 3/4 | 3.6 | 7.2 | 2.40 | 4.8 | 3.36 | 2.40 | 2.40 | 5.04 | 3.60 | 2.40 | | | | | | | |
| 8-232-038 | 7/8 | 4.5 | 9.0 | 3.00 | 6.0 | 4.20 | 3.00 | 3.00 | 6.30 | 4.50 | 3.00 | | | | | | | |
| 8-232-050 | 1 | 7.2 | 14.4 | 4.00 | 8.0 | 5.60 | 4.00 | 4.00 | 8.40 | 6.00 | 4.00 | | | | | | | |
| 8-232-078 | 1 1/4 | 9.6 | 19.2 | 6.25 | 12.5 | 8.75 | 6.25 | 6.25 | 13.13 | 9.38 | 6.25 | | | | | | | |
| 8-232-125 | 1 1/2 | 11.0 | 22.0 | 10.00 | 20.0 | 14.00 | 10.00 | 10.00 | 21.00 | 15.00 | 10.00 | | | | | | | |
| 8-232-200 | 2 | 16.0 | 32.0 | 16.00 | 32.0 | 22.40 | 16.00 | 16.00 | 33.60 | 24.00 | 16.00 | | | | | | | |

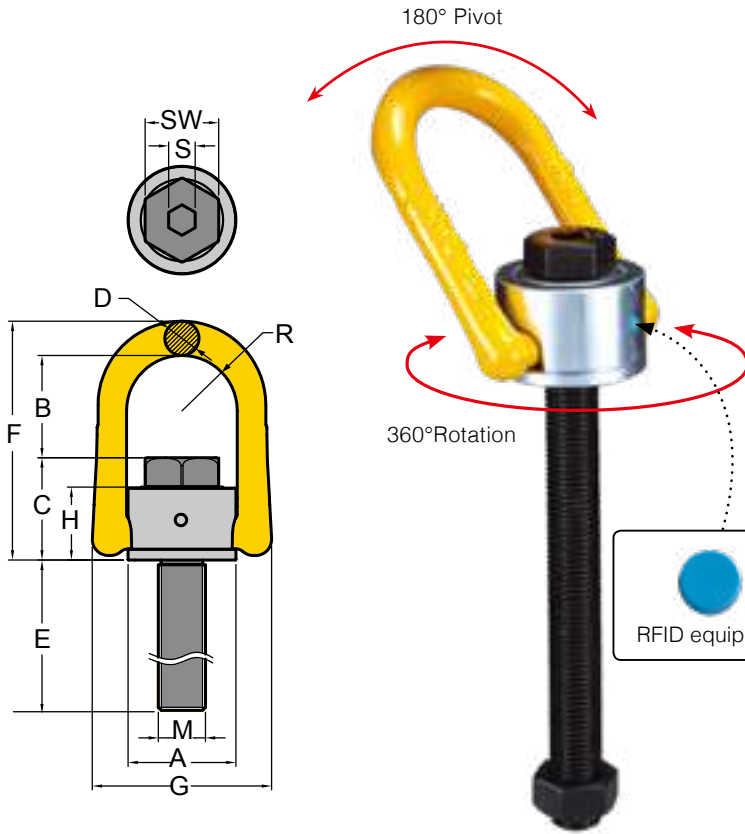

- Rotates through 360° and pivots 180°, and simultaneously allows lifting from any direction.
- Manufactured from forged alloy steel, quenched and tempered.
- Tested in accordance with EN1677-1.
- Load rated parts are 100% magnaflux crack detected.
- Individual forged parts and cap screw are traceable to Test Certification.
- Bolts are Metric thread.
- Proof tested to 2.5 times the WLL.
- Fatigue rated to 20,000 cycles at 1.5 times the WLL.
- All YOKE Lifting points meet or exceed all the requirements of ASME B30.26.
- Quick and simple assembly, just a tapped hole is required.

» Taiwan Patent
» China Patent

Anchor Point Long Bolt

Metric Thread (8-231L)



| Item No. | Working Load Limit tonnes | Thread version | | | Dimensions | | | | | | | | | | Torque in Nm | N.W. kg | |
|----------------|------------------------------|----------------|-----|----------------|------------|-----|-----|----|-----|-----|----|----|----|----|-----------------|------------|------|
| | | M | E | Pitch DIN13 | A | B | C | D | F | G | H | R | S | SW | | | I |
| 8-231-005/105L | 0.5 | M 8 | 83 | 1.25 | 33 | 42 | 28 | 11 | 80 | 58 | 23 | 17 | 6 | 13 | 44 | 30 | 0.3 |
| 8-231-007/125L | 0.7 | M 10 | 103 | 1.50 | 33 | 41 | 29 | 11 | 80 | 58 | 23 | 17 | 6 | 17 | 44 | 60 | 0.3 |
| 8-231-010/150L | 1.0 | M 12 | 128 | 1.75 | 33 | 39 | 31 | 11 | 80 | 58 | 23 | 17 | 8 | 19 | 44 | 100 | 0.4 |
| 8-231-020/185L | 2.0 | M 16 | 149 | 2.00 | 50 | 54 | 46 | 17 | 116 | 90 | 36 | 27 | 10 | 24 | 63 | 150 | 1.0 |
| 8-231-030/230L | 3.0 | M 20 | 194 | 2.50 | 51 | 52 | 49 | 17 | 116 | 90 | 37 | 27 | 12 | 30 | 63 | 250 | 2.0 |
| 8-231-050/265L | 5.0 | M 24 | 222 | 3.00 | 72 | 81 | 59 | 25 | 163 | 126 | 45 | 37 | 14 | 36 | 88 | 400 | 2.8 |
| 8-231-078/340L | 7.8 | M 30 | 278 | 3.50 | 87 | 94 | 81 | 30 | 204 | 148 | 62 | 46 | 17 | 46 | 110 | 500 | 4.8 |
| 8-231-125/300L | 12.5 | M 36 | 226 | 4.00 | 109 | 112 | 98 | 36 | 248 | 188 | 75 | 57 | 22 | 55 | 128 | 1000 | 10.6 |
| 8-231-156/350L | 15.6 | M 42 | 268 | 4.50 | 110 | 101 | 108 | 36 | 248 | 188 | 82 | 57 | 24 | 65 | 128 | 1500 | 11.3 |
| 8-231-200/385L | 20.0 | M 48 | 303 | 5.00 | 110 | 97 | 112 | 36 | 248 | 188 | 82 | 57 | 27 | 75 | 128 | 2000 | 13.3 |

* Design Factor 4:1



| Kind of attachment | | | | | | | | | | | | | | | | |
|--------------------|----------------|----------------|------|------|------|------|------|------|------|------|------|-----|-----|-----|-----|--|
| | Number of legs | Load direction | 1 | 2 | 1 | 2 | 2 | 2 | 2 | 3-4 | 3-4 | 3-4 | 3-4 | 3-4 | 3-4 | |
| Item No. | Thread | WLL(t) | | | | | | | | | | | | | | |
| 8-231-005/105L | M 8 | 0.8 | 1.6 | 0.5 | 1.0 | 0.7 | 0.5 | 0.5 | 1.1 | 0.8 | 0.5 | | | | | |
| 8-231-007/125L | M10 | 1.2 | 2.4 | 0.7 | 1.4 | 1.0 | 0.7 | 0.7 | 1.5 | 1.1 | 0.7 | | | | | |
| 8-231-010/150L | M12 | 1.5 | 3.0 | 1.0 | 2.0 | 1.4 | 1.0 | 1.0 | 2.1 | 1.5 | 1.0 | | | | | |
| 8-231-020/185L | M16 | 3.2 | 6.4 | 2.0 | 4.0 | 2.8 | 2.0 | 2.0 | 4.2 | 3.0 | 2.0 | | | | | |
| 8-231-030/230L | M20 | 4.5 | 9.0 | 3.0 | 6.0 | 4.2 | 3.0 | 3.0 | 6.3 | 4.5 | 3.0 | | | | | |
| 8-231-050/265L | M24 | 9.0 | 18.0 | 5.0 | 10.0 | 7.0 | 5.0 | 5.0 | 10.5 | 7.5 | 5.0 | | | | | |
| 8-231-078/340L | M30 | 12.0 | 24.0 | 7.8 | 15.6 | 10.9 | 7.8 | 7.8 | 16.4 | 11.7 | 7.8 | | | | | |
| 8-231-125/300L | M36 | 14.0 | 28.0 | 12.5 | 25.0 | 17.5 | 12.5 | 12.5 | 26.3 | 18.8 | 12.5 | | | | | |
| 8-231-156/350L | M42 | 16.0 | 32.0 | 15.6 | 31.2 | 21.8 | 15.6 | 15.6 | 32.8 | 23.4 | 15.6 | | | | | |
| 8-231-200/385L | M48 | 20.0 | 40.0 | 20.0 | 40.0 | 28.0 | 20.0 | 20.0 | 42.0 | 30.0 | 20.0 | | | | | |

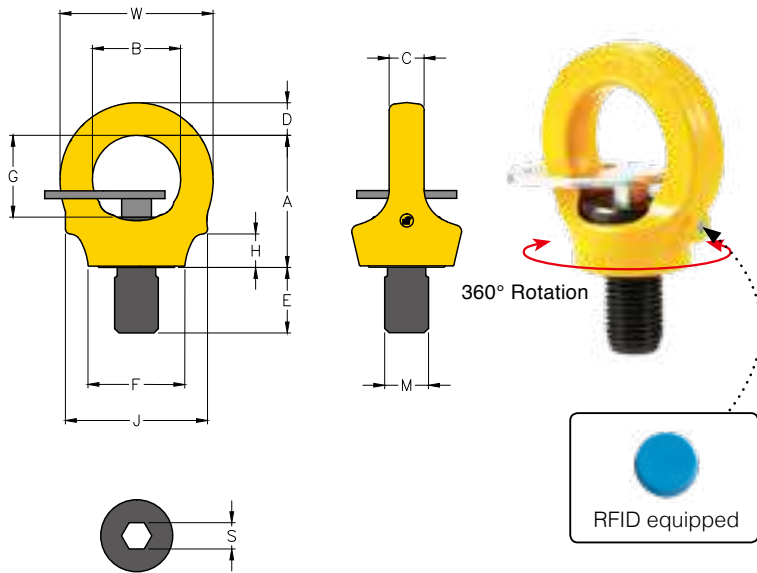

- Rotates through 360° adjustable in the direction of the load.
- Manufactured from alloy steel, quenched and tempered.
- Tested in accordance with EN1677-1.
- Certified by DGUV GS-OA 15-04
- Load rated parts are 100% magnaflux crack detected.
- Individual forged parts and cap screw are traceable to Test Certification.
- Bolts are Metric thread.
- Proof tested to 2.5 times the WLL.
- Fatigue rated to 20,000 cycles at 1.5 times the WLL.
- All YOKE Lifting points meet or exceed all the requirements of ASME B30.26.
- Quick and simple assembly, just a tapped hole is required.

- » Taiwan Patent
- » China Patent
- » French Patent
- » Australian Patent
- » Mexican Patent
- » Japanese Patent

Key Eye Point

Metric Thread (8-291K)



| Item No. | Working Load Limit | Thread version | | | Dimensions | | | | | | | | | | Torque in | N.W. | | |
|------------|--------------------|----------------|----|-------|------------|-----|----|----|-----|----|----|-----|----|-----|-----------|------|----|----|
| | | M | E | Pitch | A | B | C | D | F | G | H | J | S | W | | | Nm | kg |
| | tonnes | mm | mm | DIN13 | mm | | | | | | | | | | | | | |
| 8-291K-001 | 0.10 NEW | M 6 | 9 | 1.00 | 30 | 20 | 7 | 7 | 23 | 19 | 4 | 33 | 6 | 34 | 5 | 0.1 | | |
| 8-291K-003 | 0.30 | M 8 | 12 | 1.25 | 38 | 25 | 9 | 9 | 25 | 24 | 6 | 41 | 6 | 44 | 10 | 0.1 | | |
| 8-291K-004 | 0.40 | M 10 | 15 | 1.50 | 38 | 25 | 9 | 9 | 25 | 24 | 6 | 41 | 6 | 44 | 10 | 0.1 | | |
| 8-291K-007 | 0.75 | M 12 | 18 | 1.75 | 45 | 30 | 10 | 11 | 33 | 30 | 9 | 47 | 8 | 52 | 10 | 0.2 | | |
| 8-291K-015 | 1.50 | M 16 | 24 | 2.00 | 52 | 35 | 14 | 13 | 35 | 34 | 11 | 56 | 10 | 61 | 30 | 0.4 | | |
| 8-291K-023 | 2.30 | M 20 | 30 | 2.50 | 60 | 40 | 16 | 15 | 44 | 37 | 15 | 65 | 12 | 70 | 70 | 0.6 | | |
| 8-291K-032 | 3.20 | M 24 | 36 | 3.00 | 72 | 49 | 19 | 18 | 53 | 47 | 19 | 78 | 14 | 84 | 150 | 1.1 | | |
| 8-291K-045 | 4.50 | M 30 | 45 | 3.50 | 91 | 61 | 24 | 22 | 62 | 59 | 23 | 95 | 17 | 105 | 350 | 2.1 | | |
| 8-291K-070 | 7.00 | M 36 | 54 | 4.00 | 110 | 73 | 29 | 27 | 76 | 72 | 31 | 114 | 22 | 126 | 410 | 3.7 | | |
| 8-291K-090 | 9.00 | M 42 | 63 | 4.50 | 128 | 83 | 34 | 32 | 89 | 81 | 38 | 132 | 24 | 147 | 550 | 5.8 | | |
| 8-291K-120 | 12.00 | M 48 | 72 | 5.00 | 145 | 95 | 38 | 37 | 105 | 94 | 44 | 150 | 27 | 168 | 550 | 8.6 | | |
| 8-291K-140 | 16.00 | M 56 | 84 | 5.50 | 148 | 102 | 40 | 43 | 124 | 92 | 49 | 166 | 27 | 178 | 800 | 11.0 | | |
| 8-291K-150 | 18.00 | M 64 | 96 | 6.00 | 148 | 102 | 40 | 43 | 124 | 92 | 49 | 166 | 27 | 178 | 800 | 11.8 | | |

* Design Factor 4:1



| Kind of attachment | A | | A | | B | | B | | B | | B | |
|--------------------|----------------|--------|-----|------|-------|-----------|---------|---------|---------|-----------|---------|---------|
| | G | G | G | G | G | G | G | G | G | G | G | G |
| Number of legs | 1 | 2 | 1 | 2 | 2 | 2 | 2 | 2 | 3-4 | 3-4 | 3-4 | 3-4 |
| Load direction | 0° | 0° | 90° | 90° | 0-45° | 45° - 60° | unsymm. | unsymm. | 0 - 45° | 45° - 60° | unsymm. | unsymm. |
| Item No. | Thread | WLL(t) | | | | | | | | | | |
| 8-291K-001 | M 6 NEW | 0.5 | 1 | 0.10 | 0.2 | 0.14 | 0.10 | 0.10 | 0.21 | 0.15 | 0.10 | 0.10 |
| 8-291K-003 | M 8 | 1 | 2 | 0.30 | 0.6 | 0.42 | 0.30 | 0.30 | 0.63 | 0.45 | 0.30 | 0.30 |
| 8-291K-004 | M10 | 1 | 2 | 0.40 | 0.8 | 0.56 | 0.40 | 0.40 | 0.84 | 0.60 | 0.40 | 0.40 |
| 8-291K-007 | M12 | 2 | 4 | 0.75 | 1.5 | 1.00 | 0.75 | 0.75 | 1.58 | 1.12 | 0.75 | 0.75 |
| 8-291K-015 | M16 | 4 | 8 | 1.50 | 3.0 | 2.10 | 1.50 | 1.50 | 3.15 | 2.25 | 1.50 | 1.50 |
| 8-291K-023 | M20 | 6 | 12 | 2.30 | 4.6 | 3.20 | 2.30 | 2.30 | 4.83 | 3.45 | 2.30 | 2.30 |
| 8-291K-032 | M24 | 8 | 16 | 3.2 | 6.4 | 4.5 | 3.2 | 3.2 | 6.7 | 4.8 | 3.2 | 3.2 |
| 8-291K-045 | M30 | 12 | 24 | 4.5 | 9.0 | 6.3 | 4.5 | 4.5 | 9.4 | 6.7 | 4.5 | 4.5 |
| 8-291K-070 | M36 | 16 | 32 | 7.0 | 14.0 | 9.8 | 7.0 | 7.0 | 14.7 | 10.5 | 7.0 | 7.0 |
| 8-291K-090 | M42 | 24 | 48 | 9.0 | 18.0 | 12.6 | 9.0 | 9.0 | 18.9 | 13.5 | 9.0 | 9.0 |
| 8-291K-120 | M48 | 32 | 64 | 12.0 | 24.0 | 16.8 | 12.0 | 12.0 | 25.2 | 18.0 | 12.0 | 12.0 |
| 8-291K-140 | M56 | 34 | 68 | 16.0 | 32.0 | 22.4 | 16.0 | 16.0 | 33.6 | 24.0 | 16.0 | 16.0 |
| 8-291K-150 | M64 | 36 | 72 | 18.0 | 36.0 | 25.2 | 18.0 | 18.0 | 37.8 | 27.0 | 18.0 | 18.0 |

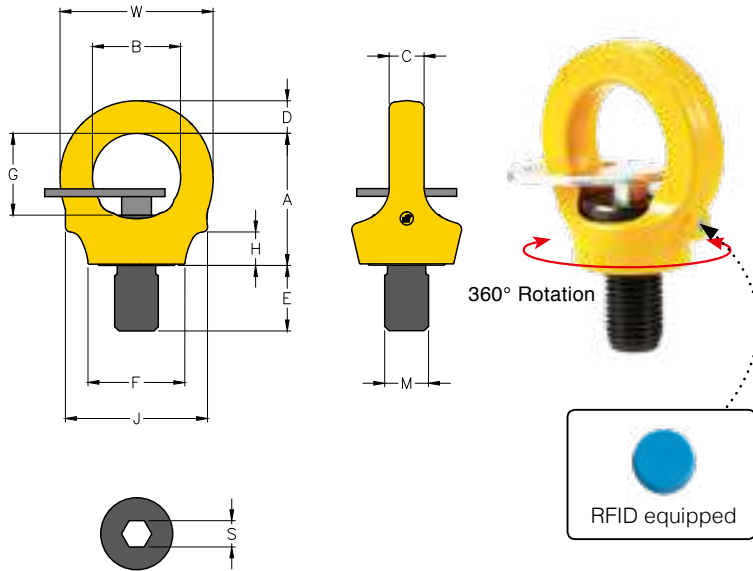

- Rotates through 360° adjustable in the direction of the load.
- Manufactured from alloy steel, quenched and tempered.
- Tested in accordance with EN1677-1.
- Load rated parts are 100% magnaflux crack detected.
- Individual forged parts and cap screw are traceable to Test Certification.
- Bolts are UNC thread.
- Proof tested to 2.5 times the WLL.
- Fatigue rated to 20,000 cycles at 1.5 times the WLL.
- All YOKE Lifting points meet or exceed all the requirements of ASME B30.26.
- Quick and simple assembly, just a tapped hole is required.

- » Taiwan Patent
- » China Patent
- » French Patent
- » Australian Patent
- » Mexican Patent
- » Japanese Patent

Key Eye Point

UNC Thread (8-292K)



| Item No. | Working Load Limit tonnes | Thread version | | | Dimensions | | | | | | | | | | Torque in Nm | N.W. lbs |
|------------|------------------------------|----------------|-----------|--------|------------|------|------|------|------|------|------|------|------|------|--------------------|-------------|
| | | M inch | E inch | TPI | A | B | C | D | F | G | H | J | S | W | | |
| 8-292K-003 | 0.30 | 5/16 | 0.47 | 18UNC | 1.49 | 1.00 | 0.33 | 0.37 | 0.99 | 0.92 | 0.24 | 1.60 | 0.25 | 1.73 | 10 | 0.3 |
| 8-292K-004 | 0.40 | 3/8 | 0.55 | 16UNC | 1.49 | 1.00 | 0.33 | 0.37 | 0.99 | 0.92 | 0.24 | 1.60 | 0.25 | 1.73 | 10 | 0.3 |
| 8-292K-007 | 0.75 | 1/2 | 0.75 | 13UNC | 1.79 | 1.19 | 0.39 | 0.43 | 1.30 | 1.16 | 0.37 | 1.85 | 0.31 | 2.05 | 10 | 0.5 |
| 8-292K-015 | 1.50 | 5/8 | 0.94 | 11UNC | 2.06 | 1.39 | 0.55 | 0.51 | 1.38 | 1.32 | 0.45 | 2.20 | 0.37 | 2.40 | 30 | 0.9 |
| 8-292K-023 | 2.30 | 3/4 | 1.14 | 10UNC | 2.38 | 1.59 | 0.63 | 0.58 | 1.74 | 1.47 | 0.60 | 2.56 | 0.5 | 2.76 | 70 | 1.4 |
| 8-292K-025 | 2.30 | 7/8 | 1.30 | 9UNC | 2.38 | 1.59 | 0.63 | 0.58 | 1.74 | 1.47 | 0.60 | 2.56 | 0.5 | 2.76 | 150 | 1.5 |
| 8-292K-032 | 3.20 | 1 | 1.52 | 8UNC | 2.85 | 1.91 | 0.75 | 0.70 | 2.08 | 1.79 | 0.75 | 3.07 | 0.56 | 3.31 | 150 | 2.5 |
| 8-292K-045 | 4.50 | 1 1/4 | 1.89 | 7UNC | 3.57 | 2.38 | 0.94 | 0.88 | 2.43 | 2.23 | 0.91 | 3.75 | 0.63 | 4.13 | 350 | 4.7 |
| 8-292K-070 | 7.00 | 1 1/2 | 2.24 | 6UNC | 4.32 | 2.85 | 1.14 | 1.05 | 2.99 | 2.71 | 1.20 | 4.49 | 0.87 | 4.96 | 410 | 8.7 |
| 8-292K-090 | 9.00 | 1 3/4 | 2.64 | 5UNC | 5.02 | 3.26 | 1.34 | 1.26 | 3.51 | 3.09 | 1.50 | 5.20 | 1.00 | 5.79 | 550 | 12.7 |
| 8-292K-120 | 12.00 | 2 | 3.03 | 4.5UNC | 5.70 | 3.74 | 1.50 | 1.44 | 4.12 | 3.69 | 1.75 | 5.91 | 1.00 | 6.61 | 550 | 19.6 |

*Design Factor 4:1



| Kind of attachment | | | | | | | | | | | |
|--------------------|--------|--------|----|------|------|-------|-----------|---------|---------|-----------|---------|
| Number of legs | | 1 | 2 | 1 | 2 | 2 | 2 | 2 | 3-4 | 3-4 | 3-4 |
| Load direction | | 0° | 0° | 90° | 90° | 0-45° | 45° - 60° | unsymm. | 0 - 45° | 45° - 60° | unsymm. |
| Item No. | Thread | WLL(t) | | | | | | | | | |
| 8-292K-003 | 5/16 | 1 | 2 | 0.30 | 0.6 | 0.42 | 0.30 | 0.30 | 0.63 | 0.45 | 0.30 |
| 8-292K-004 | 3/8 | 1 | 2 | 0.40 | 0.8 | 0.56 | 0.40 | 0.40 | 0.84 | 0.60 | 0.40 |
| 8-292K-007 | 1/2 | 2 | 4 | 0.75 | 1.5 | 1.00 | 0.75 | 0.75 | 1.58 | 1.12 | 0.75 |
| 8-292K-015 | 5/8 | 4 | 8 | 1.50 | 3.0 | 2.10 | 1.50 | 1.50 | 3.15 | 2.25 | 1.50 |
| 8-292K-023 | 3/4 | 6 | 12 | 2.30 | 4.6 | 3.20 | 2.30 | 2.30 | 4.83 | 3.45 | 2.30 |
| 8-292K-025 | 7/8 | 6 | 12 | 2.30 | 4.6 | 3.20 | 2.30 | 2.30 | 4.83 | 3.45 | 2.30 |
| 8-292K-032 | 1 | 8 | 16 | 3.2 | 6.4 | 4.5 | 3.2 | 3.2 | 6.7 | 4.8 | 3.2 |
| 8-292K-045 | 1 1/4 | 12 | 24 | 4.5 | 9.0 | 6.3 | 4.5 | 4.5 | 9.4 | 6.7 | 4.5 |
| 8-292K-070 | 1 1/2 | 16 | 32 | 7.0 | 14.0 | 9.8 | 7.0 | 7.0 | 14.7 | 10.5 | 7.0 |
| 8-292K-090 | 1 3/4 | 24 | 48 | 9.0 | 18.0 | 12.6 | 9.0 | 9.0 | 18.9 | 13.5 | 9.0 |
| 8-292K-120 | 2 | 32 | 64 | 12.0 | 24.0 | 16.8 | 12.0 | 12.0 | 25.2 | 18.0 | 12.0 |

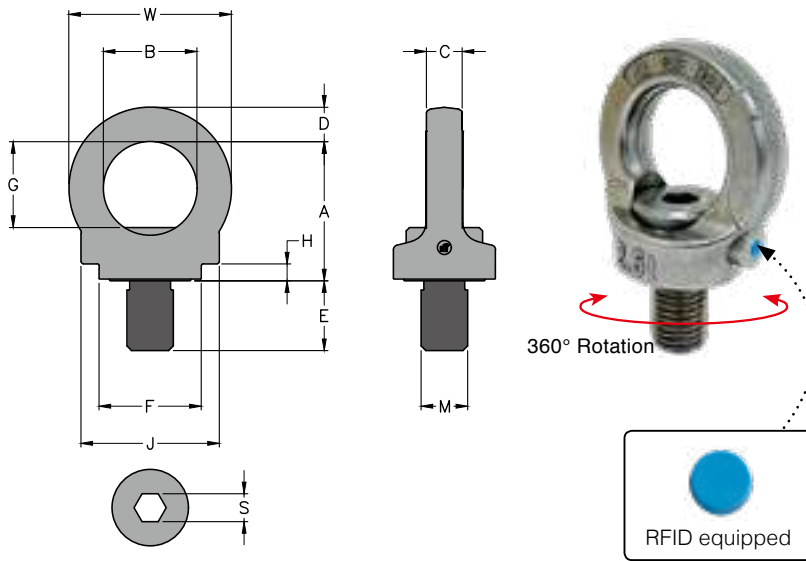

- Rotates through 360° adjustable in the direction of the load.
- Manufactured from stainless steel.
- Tested in accordance with EN1677-1.
- Individual forged parts and cap screw are traceable to Test Certification.
- Bolts are Metric thread.
- Proof tested to 2.5 times the WLL.
- Fatigue rated to 20,000 cycles at 1.5 times the WLL.
- All YOKE Lifting points meet or exceed all the requirements of ASME B30.26.
- Quick and simple assembly, just a tapped hole is required.
- Used in different applications such as chemical oil coal industries, food processing, clean room and precision instrument.

- » Taiwan Patent
- » China Patent
- » French Patent
- » Australian Patent
- » Mexican Patent
- » Japanese Patent

Stainless Steel Eye Point

Metric Thread (8-S291)



| Item No. | Working Load Limit | Thread version | | | Dimensions | | | | | | | | | | Torque | | N.W. |
|------------|--------------------|----------------|----|-------|------------|----|----|----|----|----|----|----|----|----|--------|-----|------|
| | | M | E | Pitch | A | B | C | D | F | G | H | J | S | W | in | kg | |
| | tonnes | mm | mm | DIN13 | mm | | | | | | | | | | Nm | | |
| 8-S291-005 | 0.5 | M 12 | 18 | 1.75 | 45 | 30 | 10 | 11 | 33 | 29 | 5 | 44 | 8 | 52 | 10 | 0.2 | |
| 8-S291-010 | 1.0 | M 16 | 24 | 2.00 | 52 | 35 | 14 | 13 | 35 | 33 | 5 | 51 | 10 | 61 | 30 | 0.3 | |
| 8-S291-020 | 2.0 | M 20 | 30 | 2.50 | 60 | 40 | 16 | 15 | 44 | 37 | 7 | 60 | 12 | 70 | 70 | 0.6 | |
| 8-S291-025 | 2.5 | M 24 | 36 | 3.00 | 72 | 49 | 19 | 18 | 52 | 46 | 10 | 72 | 14 | 84 | 150 | 1.0 | |

* Design Factor 4:1



| Kind of attachment | | | | | | | | | | | | | | | | | |
|--------------------|----------------|----------------|------|-----|---|-----|-----|-----|-----|-----|-----|-----|-----|-----|-----|-----|-----|
| | Number of legs | Load direction | 1 | 2 | 1 | 2 | 2 | 2 | 2 | 2 | 3-4 | 3-4 | 3-4 | 3-4 | 3-4 | 3-4 | |
| Item No. | Thread | WLL(t) | | | | | | | | | | | | | | | |
| 8-S291-005 | M12 | 1.2 | 2.4 | 0.5 | 1 | 0.7 | 0.5 | 0.5 | 1.0 | 0.7 | 0.5 | 2.1 | 1.5 | 1.0 | 4.2 | 3.0 | 2.0 |
| 8-S291-010 | M16 | 2.4 | 4.8 | 1.0 | 2 | 1.4 | 1.0 | 1.0 | 2.1 | 1.5 | 1.0 | 4.2 | 3.0 | 2.0 | 5.3 | 3.7 | 2.5 |
| 8-S291-020 | M20 | 3.6 | 7.2 | 2.0 | 4 | 2.8 | 2.0 | 2.0 | 4.2 | 3.0 | 2.0 | 5.3 | 3.7 | 2.5 | | | |
| 8-S291-025 | M24 | 5.2 | 10.4 | 2.5 | 5 | 3.5 | 2.5 | 2.5 | 5.3 | 3.7 | 2.5 | | | | | | |

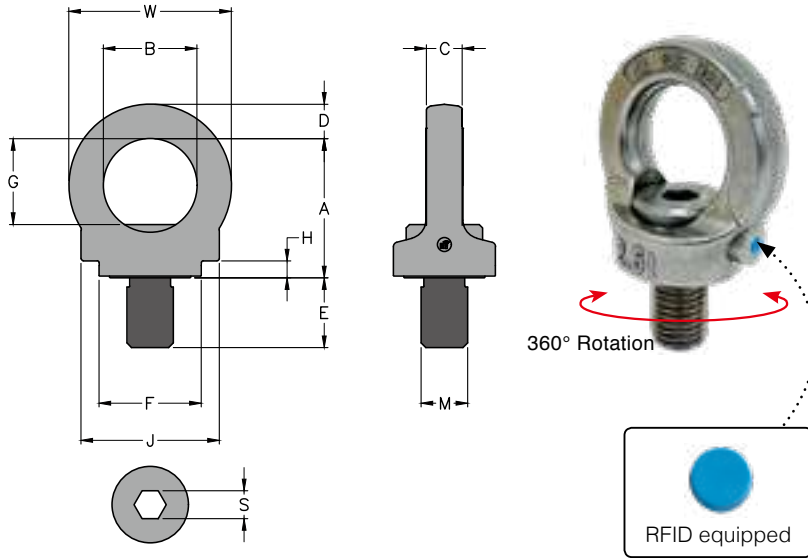

- Rotates through 360° adjustable in the direction of the load.
- Manufactured from stainless steel.
- Tested in accordance with EN1677-1.
- Individual forged parts and cap screw are traceable to Test Certification.
- Bolts are UNC thread.
- Proof tested to 2.5 times the WLL.
- Fatigue rated to 20,000 cycles at 1.5 times the WLL.
- All YOKE Lifting points meet or exceed all the requirements of ASME B30.26.
- Quick and simple assembly, just a tapped hole is required.
- Used in different applications such as chemical oil coal industries, food processing, clean room and precision instrument.

- » Taiwan Patent
- » China Patent
- » French Patent
- » Australian Patent
- » Mexican Patent
- » Japanese Patent

Stainless Steel Eye Point

UNC Thread (8-S292)



| Item No. | Working Load Limit | Thread version | | | Dimensions | | | | | | | | | | Torque | | N.W. | |
|------------|--------------------|----------------|------|-------|------------|------|------|------|------|------|------|------|------|------|--------|-----|------|-----|
| | | M | E | TPI | A | B | C | D | F | G | H | J | S | W | in | Nm | | lbs |
| | tonnes | inch | inch | | | | | | | | | | | | | | | |
| 8-S292-005 | 0.5 | 1/2 | 0.75 | 13UNC | 1.77 | 1.18 | 0.39 | 0.43 | 1.30 | 1.14 | 0.2 | 1.73 | 0.31 | 0.31 | 10 | 0.4 | | |
| 8-S292-010 | 1 | 5/8 | 0.94 | 11UNC | 2.05 | 1.38 | 0.55 | 0.51 | 1.38 | 1.30 | 0.2 | 2.01 | 0.39 | 0.39 | 30 | 0.7 | | |
| 8-S292-020 | 2 | 3/4 | 1.40 | 10UNC | 2.36 | 1.57 | 0.63 | 0.59 | 1.73 | 1.46 | 0.28 | 2.36 | 0.47 | 0.47 | 70 | 1.3 | | |
| 8-S292-025 | 2.5 | 1 | 1.52 | 8UNC | 2.83 | 1.93 | 0.75 | 0.71 | 2.05 | 1.81 | 0.39 | 2.83 | 0.55 | 0.55 | 150 | 2.2 | | |

* Design Factor 4:1



| Kind of attachment | | | | | | | | | | | |
|--------------------|--------|--------|------|-----|-----|-------|-----------|---------|---------|-----------|---------|
| Number of legs | | 1 | 2 | 1 | 2 | 2 | 2 | 2 | 3-4 | 3-4 | 3-4 |
| Load direction | | 0° | 0° | 90° | 90° | 0-45° | 45° - 60° | unsymm. | 0 - 45° | 45° - 60° | unsymm. |
| Item No. | Thread | WLL(t) | | | | | | | | | |
| 8-S292-005 | 1/2 | 1.2 | 2.4 | 0.5 | 1 | 0.7 | 0.5 | 0.5 | 1.0 | 0.7 | 0.5 |
| 8-S292-010 | 5/8 | 2.4 | 4.8 | 1.0 | 2 | 1.4 | 1.0 | 1.0 | 2.1 | 1.5 | 1.0 |
| 8-S292-020 | 3/4 | 3.6 | 7.2 | 2.0 | 4 | 2.8 | 2.0 | 2.0 | 4.2 | 3.0 | 2.0 |
| 8-S292-025 | 1 | 5.2 | 10.4 | 2.5 | 5 | 3.5 | 2.5 | 2.5 | 5.3 | 3.7 | 2.5 |



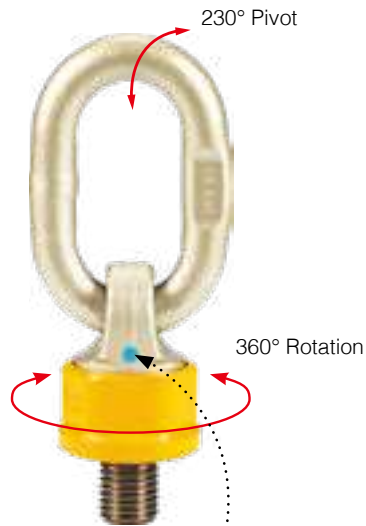
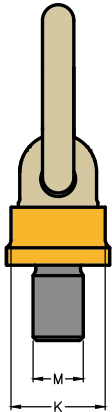
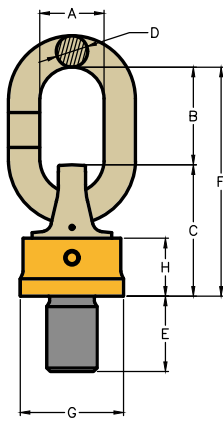

- Pivots to 230°, rotates through 360° due to its unique ball bearing design.
- Manufactured from forged alloy steel, quenched and tempered.
- Tested in accordance with EN1677-4.
- All YOKE Lifting points meet or Certified by DGUV GS-OA-15-04.
- Load rated parts are 100% magnaflux crack detected.
- Individual forged parts and batch code links to Test Certificate sheet.
- Bolts are Metric thread.
- Proof tested to 2.5 times the WLL.
- Fatigue rated to 20,000 cycles at 1.5 times the WLL.
- All YOKE Lifting points meet or exceed all the requirements of ASME B30.26.
- Easy to attach or dismantle due to the forged hexagon shaped body of the Super Point
- Capable of rotating under load. Do not turn continuously in 90 degree direction at full load.
- With the new WLL tables you can find the right Super Point attachment for your application and by the yellow marking on both sides you can measure disposal stage of the Super Point.

Super Point

Metric Thread (8-251)



Super Point

UNC Thread (8-252)



* Design Factor 4:1

Super Point

Metric Thread (8-251)

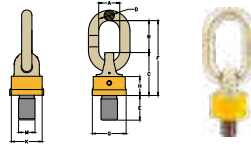

| Item No. | Working Load Limit tonnes | Thread version | | | Dimensions | | | | | | | | Torque in Nm | N.W. kg |
|----------------------|------------------------------|----------------|-----|-------|------------|-----|-----|------|-----|----|-----|----|--------------------|------------|
| | | M | E | Pitch | G | C | K | H | F | D | B | A | | |
| | | mm | mm | DIN13 | mm | | | | | | | | | |
| 8-251-004-01 | 0.3 | M 8 | 12 | 1.25 | 36.5 | 48 | 34 | 20.5 | 101 | 13 | 53 | 35 | 10 - 40 | 0.30 |
| 8-251-007-01 | 0.5 | M10 | 18 | 1.50 | 36.5 | 48 | 34 | 20.5 | 101 | 13 | 53 | 35 | 10 - 40 | 0.40 |
| 8-251-007-02 | 0.7 | M12 | 18 | 1.75 | 36.5 | 48 | 34 | 20.5 | 101 | 13 | 53 | 35 | 15 - 40 | 0.40 |
| 8-251-007-03 | 0.7 | M12 | 25 | 1.75 | 36.5 | 48 | 34 | 20.5 | 101 | 13 | 53 | 35 | 15 - 40 | 0.40 |
| 8-251-007-04 | 1.0 | M14 | 20 | 2.00 | 36.5 | 48 | 34 | 20.5 | 101 | 13 | 53 | 35 | 30 - 40 | 0.40 |
| 8-251-014-01 | 1.4 | M16 | 20 | 2.00 | 36.5 | 48 | 34 | 20.5 | 101 | 13 | 53 | 35 | 45 - 130 | 0.44 |
| 8-251-014-02 | 1.4 | M16 | 24 | 2.00 | 36.5 | 48 | 34 | 20.5 | 101 | 13 | 53 | 35 | 45 - 130 | 0.50 |
| 8-251-014-03 | 1.4 | M16 | 30 | 2.00 | 36.5 | 48 | 34 | 20.5 | 101 | 13 | 53 | 35 | 45 - 130 | 0.50 |
| 8-251-014-04 | 1.7 | M20 | 30 | 2.50 | 36.5 | 48 | 34 | 20.5 | 101 | 13 | 53 | 35 | 75 - 130 | 0.50 |
| 8-251-014-05 | 1.7 | M24 | 30 | 3.00 | 36.5 | 48 | 34 | 20.5 | 101 | 13 | 53 | 35 | 90 - 130 | 0.50 |
| 8-251-025-01 | 2.5 | M20 | 30 | 2.50 | 52.0 | 68 | 46 | 28.0 | 127 | 16 | 59 | 35 | 100 - 170 | 1.00 |
| 8-251-025-02 | 2.5 | M20 | 40 | 2.50 | 52.0 | 68 | 46 | 28.0 | 127 | 16 | 59 | 35 | 100 - 170 | 1.00 |
| 8-251-025-03 | 2.5 | M20 | 50 | 2.50 | 52.0 | 68 | 46 | 28.0 | 127 | 16 | 59 | 35 | 100 - 170 | 1.10 |
| 8-251-025-04 | 2.5 | M20 | 70 | 2.50 | 52.0 | 68 | 46 | 28.0 | 127 | 16 | 59 | 35 | 100 - 170 | 1.10 |
| 8-251-040-01 | 4.0 | M24 | 30 | 3.00 | 57.0 | 75 | 50 | 34.5 | 148 | 19 | 73 | 40 | 190 - 280 | 1.50 |
| 8-251-040-02 | 4.0 | M24 | 36 | 3.00 | 57.0 | 75 | 50 | 34.5 | 148 | 19 | 73 | 40 | 190 - 280 | 1.50 |
| 8-251-040-03 | 4.0 | M24 | 45 | 3.00 | 57.0 | 75 | 50 | 34.5 | 148 | 19 | 73 | 40 | 190 - 280 | 1.50 |
| 8-251-040-04 | 4.0 | M24 | 50 | 3.00 | 57.0 | 75 | 50 | 34.5 | 148 | 19 | 73 | 40 | 190 - 280 | 1.50 |
| 8-251-040-05 | 4.0 | M30 | 35 | 3.50 | 57.0 | 75 | 50 | 34.5 | 148 | 19 | 73 | 40 | 190 - 280 | 1.50 |
| 8-251-067-01 | 6.7 | M30 | 35 | 3.50 | 70.0 | 95 | 65 | 41.0 | 163 | 20 | 68 | 40 | 230 - 400 | 2.40 |
| 8-251-067-02 | 6.7 | M30 | 45 | 3.50 | 70.0 | 95 | 65 | 41.0 | 163 | 20 | 68 | 40 | 230 - 400 | 2.40 |
| 8-251-067-03 | 6.7 | M30 | 50 | 3.50 | 70.0 | 95 | 65 | 41.0 | 163 | 20 | 68 | 40 | 230 - 400 | 2.50 |
| 8-251-067-04 | 6.7 | M30 | 60 | 3.50 | 70.0 | 95 | 65 | 41.0 | 163 | 20 | 68 | 40 | 230 - 400 | 2.50 |
| 8-251-080-01 | 8.0 | M30 | 35 | 3.50 | 81.0 | 106 | 75 | 48.0 | 201 | 22 | 95 | 50 | 270 - 600 | 3.60 |
| 8-251-080-02 | 8.0 | M30 | 45 | 3.50 | 81.0 | 106 | 75 | 48.0 | 201 | 22 | 95 | 50 | 270 - 600 | 3.70 |
| 8-251-100-01 | 10.0 | M36 | 50 | 4.00 | 81.0 | 106 | 75 | 48.0 | 201 | 22 | 95 | 50 | 270 - 600 | 3.80 |
| 8-251-100-02 | 10.0 | M36 | 54 | 4.00 | 81.0 | 106 | 75 | 48.0 | 201 | 22 | 95 | 50 | 270 - 600 | 3.90 |
| 8-251-125-01 | 12.5 | M42 | 50 | 4.50 | 81.0 | 106 | 75 | 48.0 | 201 | 22 | 95 | 50 | 270 - 700 | 3.90 |
| 8-251-125-02 | 12.5 | M42 | 60 | 4.50 | 81.0 | 106 | 75 | 48.0 | 201 | 22 | 95 | 50 | 270 - 700 | 4.00 |
| 8-251-125-03 | 12.5 | M42 | 63 | 4.50 | 81.0 | 106 | 75 | 48.0 | 201 | 22 | 95 | 50 | 270 - 700 | 4.00 |
| 8-251-125-04 | 12.5 | M45 | 60 | 4.50 | 81.0 | 106 | 75 | 48.0 | 201 | 22 | 95 | 50 | 270 - 700 | 4.10 |
| 8-251-125-05 | 12.5 | M48 | 72 | 5.00 | 81.0 | 106 | 75 | 48.0 | 201 | 22 | 95 | 50 | 270 - 700 | 4.40 |
| 8-251-170-01 | 13.0 | M42 | 60 | 4.50 | 104.0 | 127 | 95 | 58.0 | 256 | 32 | 129 | 70 | 350 - 800 | 7.40 |
| 8-251-170-02 | 17.0 | M45 | 60 | 4.50 | 104.0 | 127 | 95 | 58.0 | 256 | 32 | 129 | 70 | 350 - 800 | 7.50 |
| 8-251-170-03 | 17.0 | M48 | 60 | 5.00 | 104.0 | 127 | 95 | 58.0 | 256 | 32 | 129 | 70 | 350 - 800 | 7.60 |
| 8-251-170-04 | 17.0 | M48 | 72 | 5.00 | 104.0 | 127 | 95 | 58.0 | 256 | 32 | 129 | 70 | 350 - 800 | 7.70 |
| 8-251-170-045 | 17.0 | M52 | 78 | 5.00 | 104.0 | 127 | 95 | 58.0 | 256 | 32 | 129 | 70 | 350 - 800 | 7.90 |
| 8-251-170-05 | 18.0 | M56 | 78 | 5.50 | 104.0 | 127 | 95 | 58.0 | 256 | 32 | 129 | 70 | 350 - 900 | 8.10 |
| 8-251-170-06 | 18.0 | M56 | 84 | 5.50 | 104.0 | 127 | 95 | 58.0 | 256 | 32 | 129 | 70 | 350 - 900 | 8.10 |
| 8-251-200-01 | 20.0 | M64 | 96 | 6.00 | 104.0 | 127 | 95 | 58.0 | 256 | 32 | 129 | 70 | 350 - 900 | 8.90 |
| 8-251-200-02 | 20.0 | M64 | 110 | 6.00 | 104.0 | 127 | 95 | 58.0 | 256 | 32 | 129 | 70 | 350 - 900 | 9.30 |
| 8-251-280-01 | 28.0 | M64 | 96 | 6.00 | 129.0 | 174 | 115 | 78.0 | 305 | 36 | 131 | 80 | 500 - 1000 | 16.40 |
| 8-251-280-02 | 28.0 | M72 | 120 | 6.00 | 129.0 | 174 | 115 | 78.0 | 305 | 36 | 131 | 80 | 500 - 1200 | 17.70 |
| 8-251-280-03 | 28.0 | M80 | 150 | 6.00 | 129.0 | 174 | 115 | 78.0 | 305 | 36 | 131 | 80 | 500 - 1200 | 19.60 |
| 8-251-350-005 | 35.0 | M72 | 108 | 6.00 | 148.0 | 187 | 135 | 83.0 | 366 | 45 | 140 | 92 | 500 - 1400 | 24.80 |
| 8-251-350-01 | 35.0 | M80 | 120 | 6.00 | 148.0 | 187 | 135 | 83.0 | 366 | 45 | 140 | 92 | 500 - 1400 | 25.30 |
| 8-251-350-02 | 35.0 | M90 | 150 | 6.00 | 148.0 | 187 | 135 | 83.0 | 366 | 45 | 140 | 92 | 500 - 1500 | 27.80 |
| 8-251-400-005 | 40.0 | M72 | 108 | 6.00 | 170.0 | 210 | 145 | 83.0 | 340 | 45 | 130 | 92 | 500 - 1500 | 30.10 |
| 8-251-400-01 | 40.0 | M80 | 120 | 6.00 | 170.0 | 210 | 145 | 83.0 | 340 | 45 | 130 | 92 | 500 - 1500 | 31.90 |
| 8-251-400-02 | 40.0 | M90 | 115 | 6.00 | 170.0 | 210 | 145 | 83.0 | 340 | 45 | 130 | 92 | 500 - 1500 | 33.60 |
| 8-251-400-025 | 40.0 | M90 | 135 | 6.00 | 170.0 | 210 | 145 | 83.0 | 340 | 45 | 130 | 92 | 500 - 1500 | 33.90 |
| 8-251-400-03 | 40.0 | M90 | 150 | 6.00 | 170.0 | 210 | 145 | 83.0 | 340 | 45 | 130 | 92 | 500 - 1500 | 34.20 |
| 8-251-400-04 | 40.0 | M100 | 150 | 6.00 | 170.0 | 210 | 145 | 83.0 | 340 | 45 | 130 | 92 | 500 - 1700 | 35.20 |



| Kind of attachment | | | | | | | | | | | |
|--------------------|----------------|--------|-------|------|------|-------|------|------|-------|-------|------|
| Number of legs | Load direction | 1 | 2 | 1 | 2 | 2 | 2 | 2 | 3-4 | 3-4 | 3-4 |
| Item No. | Thread | WLL(t) | | | | | | | | | |
| 8-251-004 | M8 | 0.6 | 1.2 | 0.3 | 0.6 | 0.40 | 0.3 | 0.3 | 0.60 | 0.45 | 0.3 |
| | M10 | 1.0 | 2.0 | 0.5 | 1.0 | 0.70 | 0.5 | 0.5 | 1.00 | 0.75 | 0.5 |
| 8-251-007 | M12 | 1.4 | 2.8 | 0.7 | 1.4 | 1.00 | 0.7 | 0.7 | 1.40 | 1.00 | 0.7 |
| | M14 | 2.0 | 4.0 | 1.0 | 2.0 | 1.40 | 1.0 | 1.0 | 2.12 | 1.50 | 1.0 |
| 8-251-014 | M16 | 2.8 | 5.6 | 1.4 | 2.8 | 2.00 | 1.4 | 1.4 | 3.00 | 2.12 | 1.4 |
| | M20 | 3.4 | 6.8 | 1.7 | 3.4 | 2.40 | 1.7 | 1.7 | 3.55 | 2.50 | 1.7 |
| | M24 | 3.4 | 6.8 | 1.7 | 3.4 | 2.40 | 1.7 | 1.7 | 3.55 | 2.50 | 1.7 |
| 8-251-025 | M20 | 5.0 | 10.0 | 2.5 | 5.0 | 3.55 | 2.5 | 2.5 | 5.30 | 3.75 | 2.5 |
| 8-251-040 | M24 | 8.0 | 16.0 | 4.0 | 8.0 | 5.60 | 4.0 | 4.0 | 8.50 | 6.00 | 4.0 |
| | M30 | 8.0 | 16.0 | 4.0 | 8.0 | 5.60 | 4.0 | 4.0 | 8.50 | 6.00 | 4.0 |
| 8-251-067 | M30 | 12.0 | 24.0 | 6.7 | 13.4 | 9.50 | 6.7 | 6.7 | 14.00 | 10.00 | 6.7 |
| 8-251-080 | M30 | 12.0 | 24.0 | 8.0 | 16.0 | 11.20 | 8.0 | 8.0 | 16.00 | 12.00 | 8.0 |
| 8-251-100 | M36 | 15.0 | 30.0 | 10.0 | 20.0 | 14.0 | 10.0 | 10.0 | 21.20 | 15.00 | 10.0 |
| 8-251-125 | M42 | 15.0 | 30.0 | 12.5 | 25.0 | 17.0 | 12.5 | 12.5 | 25.00 | 18.00 | 12.5 |
| | M45 | 15.0 | 30.0 | 12.5 | 25.0 | 17.0 | 12.5 | 12.5 | 25.00 | 18.00 | 12.5 |
| | M48 | 15.0 | 30.0 | 12.5 | 25.0 | 17.0 | 12.5 | 12.5 | 25.00 | 18.00 | 12.5 |
| 8-251-170 | M42 | 20.0 | 40.0 | 13.0 | 26.0 | 18.0 | 13.0 | 13.0 | 27.00 | 19.00 | 13.0 |
| | M45 | 25.0 | 50.0 | 17.0 | 34.0 | 23.5 | 17.0 | 17.0 | 35.00 | 25.00 | 17.0 |
| | M48 | 25.0 | 50.0 | 17.0 | 34.0 | 23.5 | 17.0 | 17.0 | 35.00 | 25.00 | 17.0 |
| | M52 | 25.0 | 50.0 | 17.0 | 34.0 | 23.5 | 17.0 | 17.0 | 35.00 | 25.00 | 17.0 |
| | M56 | 25.0 | 50.0 | 18.0 | 36.0 | 25.0 | 18.0 | 18.0 | 37.50 | 26.50 | 18.0 |
| 8-251-200 | M64 | 25.0 | 50.0 | 20.0 | 40.0 | 28.0 | 20.0 | 20.0 | 42.50 | 30.00 | 20.0 |
| | M64 | 32.5 | 65.0 | 28.0 | 56.0 | 39.0 | 28.0 | 28.0 | 58.00 | 42.00 | 28.0 |
| 8-251-280 | M72 | 32.5 | 65.0 | 28.0 | 56.0 | 39.0 | 28.0 | 28.0 | 58.00 | 42.00 | 28.0 |
| | M80 | 32.5 | 65.0 | 28.0 | 56.0 | 39.0 | 28.0 | 28.0 | 58.00 | 42.00 | 28.0 |
| | M72 | 40.0 | 80.0 | 35.0 | 70.0 | 49.0 | 35.0 | 35.0 | 74.00 | 52.50 | 35.0 |
| 8-251-350 | M80 | 40.0 | 80.0 | 35.0 | 70.0 | 49.0 | 35.0 | 35.0 | 74.00 | 52.50 | 35.0 |
| | M90 | 40.0 | 80.0 | 35.0 | 70.0 | 49.0 | 35.0 | 35.0 | 74.00 | 52.50 | 35.0 |
| | M72 | 50.0 | 100.0 | 40.0 | 80.0 | 56.0 | 40.0 | 40.0 | 84.00 | 60.00 | 40.0 |
| 8-251-400 | M80 | 50.0 | 100.0 | 40.0 | 80.0 | 56.0 | 40.0 | 40.0 | 84.00 | 60.00 | 40.0 |
| | M90 | 50.0 | 100.0 | 40.0 | 80.0 | 56.0 | 40.0 | 40.0 | 84.00 | 60.00 | 40.0 |
| | M100 | 50.0 | 100.0 | 40.0 | 80.0 | 56.0 | 40.0 | 40.0 | 84.00 | 60.00 | 40.0 |

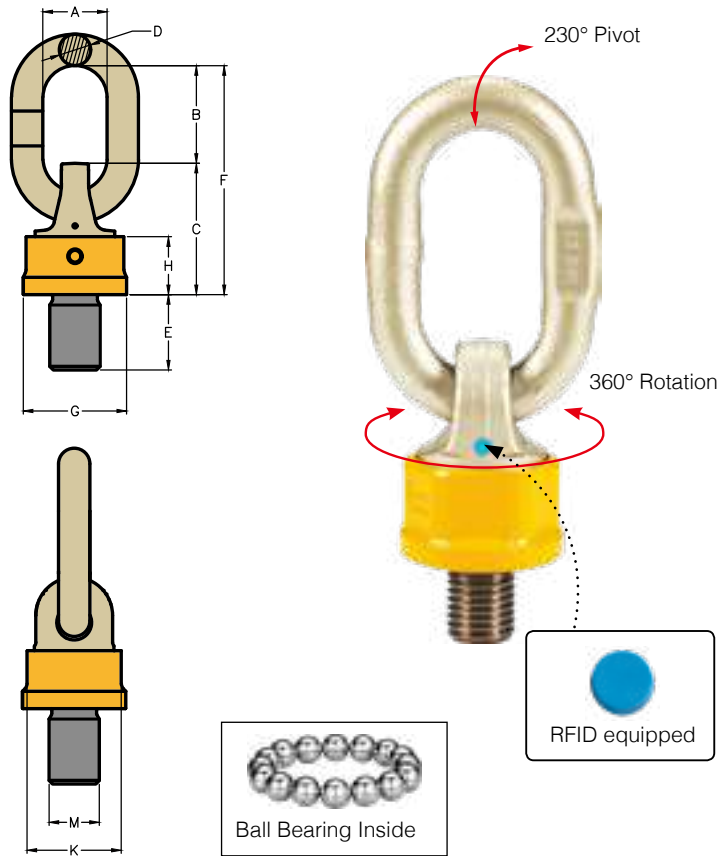

- Pivots to 230°, rotates through 360° due to its unique ball bearing design.
- Manufactured from forged alloy steel, quenched and tempered.
- Tested in accordance with EN1677-1.
- Load rated parts are 100% magnaflux crack detected.
- Individual forged parts and batch code links to Test Certificate sheet.
- Bolts are UNC thread.
- Proof tested to 2.5 times the WLL.
- Fatigue rated to 20,000 cycles at 1.5 times the WLL.
- All YOKE Lifting points meet or exceed all the requirements of ASME B30.26.
- Easy to attach or dismantle due to the forged hexagon shaped body of the Super Point.
- Capable of rotating under load. Do not turn continuously in 90 degree direction at full load.
- With the new WLL tables you can find the right Super Point attachment for your application and by the red marking on both sides you can measure disposal stage of the Super Point.

Super Point

UNC Thread (8-252)



| Item No. | Working Load Limit tonnes | Thread version | | | Dimensions | | | | | | | | Torque in Nm | N.W. lbs |
|--------------|------------------------------|----------------|-----------|--------|------------|------|------|------|-------|------|------|------|--------------------|-------------|
| | | M inch | E inch | TPI | G | C | K | H | F | D | B | A | | |
| 8-252-007-01 | 0.5 | 3/8 | 0.56 | 16UNC | 1.44 | 1.89 | 1.34 | 0.81 | 3.98 | 0.51 | 2.09 | 1.38 | 10 - 40 | 1.0 |
| 8-252-007-02 | 0.7 | 1/2 | 0.75 | 13UNC | 1.44 | 1.89 | 1.34 | 0.81 | 3.98 | 0.51 | 2.09 | 1.38 | 15 - 40 | 1.0 |
| 8-252-014-02 | 1.4 | 5/8 | 0.94 | 11UNC | 1.44 | 1.89 | 1.34 | 0.81 | 3.98 | 0.51 | 2.09 | 1.38 | 45 - 130 | 1.0 |
| 8-252-025-01 | 2.5 | 3/4 | 1.13 | 10UNC | 2.05 | 2.68 | 1.81 | 1.10 | 5.00 | 0.63 | 2.32 | 1.38 | 100 - 170 | 2.1 |
| 8-252-040-02 | 4.0 | 1 | 1.50 | 8UNC | 2.24 | 2.95 | 1.97 | 1.36 | 5.83 | 0.75 | 2.87 | 1.57 | 190 - 280 | 3.3 |
| 8-252-067-02 | 6.7 | 1 1/4 | 1.88 | 7UNC | 2.76 | 3.74 | 2.56 | 1.61 | 6.42 | 0.79 | 2.68 | 1.57 | 230 - 400 | 5.3 |
| 8-252-080-02 | 8.0 | 1 1/4 | 1.88 | 7UNC | 3.19 | 4.17 | 2.95 | 1.89 | 7.91 | 0.87 | 3.74 | 1.97 | 270 - 600 | 8.1 |
| 8-252-100-02 | 10.0 | 1 1/2 | 2.25 | 6UNC | 3.19 | 4.17 | 2.95 | 1.89 | 7.91 | 0.87 | 3.74 | 1.97 | 270 - 600 | 8.3 |
| 8-252-125-03 | 12.5 | 1 3/4 | 2.63 | 5UNC | 3.19 | 4.17 | 2.95 | 1.89 | 7.91 | 0.87 | 3.74 | 1.97 | 270 - 700 | 8.8 |
| 8-252-125-05 | 12.5 | 2 | 3.00 | 4.5UNC | 3.19 | 4.17 | 2.95 | 1.89 | 7.91 | 0.87 | 3.74 | 1.97 | 270 - 700 | 9.7 |
| 8-252-170-04 | 17.0 | 2 | 3.00 | 4.5UNC | 4.09 | 5.00 | 3.74 | 2.28 | 10.08 | 1.26 | 5.08 | 2.76 | 350 - 800 | 16.7 |
| 8-252-170-06 | 18.0 | 2 1/4 | 3.38 | 4.5UNC | 4.09 | 5.00 | 3.74 | 2.28 | 10.08 | 1.26 | 5.08 | 2.76 | 350 - 900 | 17.8 |
| 8-252-200-01 | 20.0 | 2 1/2 | 3.75 | 4UNC | 4.09 | 5.00 | 3.74 | 2.28 | 10.08 | 1.26 | 5.08 | 2.76 | 350 - 900 | 19.6 |
| 8-252-280-01 | 28.0 | 2 1/2 | 3.75 | 4UNC | 5.08 | 6.85 | 4.53 | 3.07 | 12.01 | 1.42 | 5.16 | 3.15 | 500 - 1000 | 36.1 |
| 8-252-350-01 | 35.0 | 3 1/2 | 5.25 | 4UNC | 5.83 | 7.36 | 5.31 | 3.27 | 14.41 | 1.77 | 5.51 | 3.62 | 500 - 1400 | 55.7 |

* Design Factor 4:1



| Kind of attachment | | | | | | | | | | | |
|--------------------|--------|--------|------|------|------|-------|-----------|---------|---------|-----------|---------|
| Number of legs | | 1 | 2 | 1 | 2 | 2 | 2 | 2 | 3-4 | 3-4 | 3-4 |
| Load direction | | 0° | 0° | 90° | 90° | 0-45° | 45° - 60° | unsymm. | 0 - 45° | 45° - 60° | unsymm. |
| Item No. | Thread | WLL(t) | | | | | | | | | |
| 8-252-007 | 3/8 | 1.0 | 2.0 | 0.5 | 1.0 | 0.70 | 0.5 | 0.5 | 1.0 | 0.75 | 0.5 |
| | 1/2 | 1.4 | 2.8 | 0.7 | 1.4 | 1.00 | 0.7 | 0.7 | 1.4 | 1.00 | 0.7 |
| 8-252-014 | 5/8 | 2.8 | 5.6 | 1.4 | 2.8 | 2.00 | 1.4 | 1.4 | 3.0 | 2.12 | 1.4 |
| 8-252-025 | 3/4 | 5.0 | 10.0 | 2.5 | 5.0 | 3.55 | 2.5 | 2.5 | 5.3 | 3.75 | 2.5 |
| 8-252-040 | 1 | 8.0 | 16.0 | 4.0 | 8.0 | 5.60 | 4.0 | 4.0 | 8.5 | 6.00 | 4.0 |
| 8-252-067 | 1 1/4 | 12.0 | 24.0 | 6.7 | 13.4 | 9.50 | 6.7 | 6.7 | 14.0 | 10.00 | 6.7 |
| 8-252-080 | 1 1/4 | 12.0 | 24.0 | 8.0 | 16.0 | 11.20 | 8.0 | 8.0 | 16.0 | 12.00 | 8.0 |
| 8-252-100 | 1 1/2 | 15.0 | 30.0 | 10.0 | 20.0 | 14.00 | 10.0 | 10.0 | 21.2 | 15.00 | 10.0 |
| 8-252-125 | 1 3/4 | 15.0 | 30.0 | 12.5 | 25.0 | 17.00 | 12.5 | 12.5 | 25.0 | 18.00 | 12.5 |
| | 2 | 15.0 | 30.0 | 12.5 | 25.0 | 17.00 | 12.5 | 12.5 | 25.0 | 18.00 | 12.5 |
| 8-252-170 | 2 | 25.0 | 50.0 | 17.0 | 34.0 | 23.50 | 17.0 | 17.0 | 35.0 | 25.00 | 17.0 |
| | 2 1/4 | 25.0 | 50.0 | 18.0 | 36.0 | 25.00 | 18.0 | 18.0 | 37.5 | 26.50 | 18.0 |
| 8-252-200 | 2 1/2 | 25.0 | 50.0 | 20.0 | 40.0 | 28.00 | 20.0 | 20.0 | 42.5 | 30.00 | 20.0 |
| 8-252-280 | 2 1/2 | 32.5 | 65.0 | 28.0 | 56.0 | 39.00 | 28.0 | 28.0 | 58.0 | 42.00 | 28.0 |
| 8-252-350 | 3 1/2 | 40.0 | 80.0 | 35.0 | 70.0 | 49.00 | 35.0 | 35.0 | 74.0 | 52.50 | 35.0 |

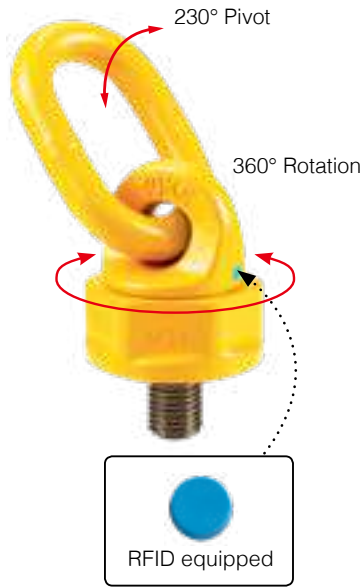
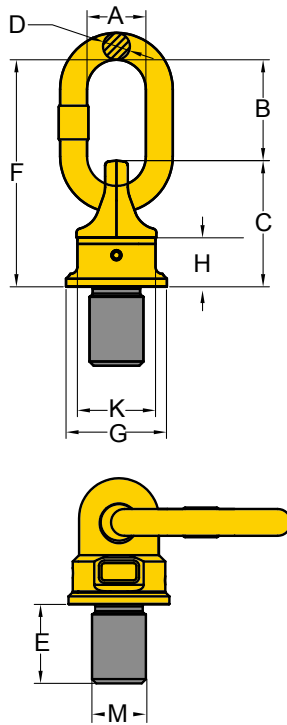

- Pivots to 230°, rotates through 360° due to its unique ball bearing design.
- Manufactured from forged alloy steel, quenched and tempered.
- Tested in accordance with EN1677-4.
- Certified by DGUV GS-OA-15-04.
- Load rated parts are 100% magnaflux crack detected.
- Individual forged parts and batch code links to Test Certificate sheet.
- Bolts are Metric thread.
- Proof tested to 2.5 times the WLL.
- Fatigue rated to 20,000 cycles at 1.5 times the WLL.
- All YOKE Lifting points meet or exceed all the requirements of ASME B30.26.
- Easy to attach or dismantle due to the forged hexagon shaped body of the Swivel Point.
- Capable of rotating under load. Do not turn continuously in 90 degree direction at full load.



Swivel Point

Metric Thread (8-271)



| Item No. | Working Load Limit tonnes | Thread version | | | Dimensions (mm) | | | | | | | | Torque | |
|-----------|------------------------------|----------------|---------|----------------|-----------------|-----|-----|----|-----|----|-----|----|--------|------------|
| | | M mm | E mm | Pitch DIN13 | G | C | K | H | F | D | B | A | Nm | N.W. kg |
| 8-271-003 | 0.4 | M 8 | 12 | 1.25 | 35 | 40 | 30 | 16 | 72 | 8 | 32 | 29 | 10 | 0.2 |
| 8-271-004 | 0.6 | M 10 | 15 | 1.50 | 35 | 40 | 30 | 16 | 72 | 8 | 32 | 29 | 10 | 0.2 |
| 8-271-006 | 0.7 | M 12 | 18 | 1.75 | 40 | 45 | 36 | 18 | 95 | 10 | 50 | 35 | 10 | 0.3 |
| 8-271-013 | 1.5 | M 16 | 24 | 2.00 | 46 | 54 | 41 | 22 | 104 | 13 | 50 | 36 | 30 | 0.5 |
| 8-271-020 | 2.5 | M 20 | 30 | 2.50 | 62 | 68 | 55 | 29 | 122 | 13 | 54 | 36 | 70 | 1.0 |
| 8-271-035 | 4.0 | M 24 | 36 | 3.00 | 78 | 88 | 70 | 36 | 154 | 19 | 66 | 41 | 150 | 2.2 |
| 8-271-060 | 6.0 | M 30 | 45 | 3.50 | 90 | 120 | 80 | 48 | 206 | 22 | 86 | 50 | 350 | 4.5 |
| 8-271-080 | 10.0 | M 36 | 54 | 4.00 | 90 | 120 | 80 | 48 | 206 | 22 | 86 | 50 | 410 | 4.6 |
| 8-271-120 | 13.0 | M 42 | 63 | 4.50 | 98 | 122 | 84 | 50 | 235 | 25 | 110 | 67 | 550 | 5.5 |
| 8-271-130 | 14.0 | M 48 | 72 | 5.00 | 98 | 122 | 84 | 50 | 235 | 25 | 110 | 67 | 550 | 6.1 |
| 8-271-140 | 20.0 | M 52 | 78 | 5.00 | 120 | 150 | 94 | 60 | 270 | 32 | 120 | 72 | 750 | 10.5 |
| 8-271-160 | 20.0 | M 56 | 84 | 5.50 | 120 | 150 | 94 | 60 | 270 | 32 | 120 | 72 | 800 | 10.7 |
| 8-271-161 | 20.0 | M 64 | 96 | 6.00 | 120 | 150 | 94 | 60 | 270 | 32 | 120 | 72 | 800 | 11.6 |
| 8-271-310 | 40.0 | M 72 | 108 | 6.00 | 170 | 210 | 145 | 83 | 340 | 45 | 130 | 90 | 1200 | 30.6 |
| 8-271-350 | 40.0 | M 80 | 120 | 6.00 | 170 | 210 | 145 | 83 | 340 | 45 | 130 | 90 | 1500 | 31.6 |
| 8-271-400 | 40.0 | M 90 | 135 | 6.00 | 170 | 210 | 145 | 83 | 340 | 45 | 130 | 90 | 2000 | 33.9 |

* Design Factor 4:1



| Kind of attachment | | | | | | | | | | | |
|--------------------|--------|--------|-------|------|-------|-----------|---------|---------|-----------|---------|------|
| Number of legs | 1 | 2 | 1 | 2 | 2 | 2 | 2 | 3-4 | 3-4 | 3-4 | |
| Load direction | 0° | 0° | 90° | 90° | 0-45° | 45° - 60° | unsymm. | 0 - 45° | 45° - 60° | unsymm. | |
| Item No. | Thread | WLL(t) | | | | | | | | | |
| 8-271-003 | M 8 | 0.6 | 1.2 | 0.4 | 0.8 | 0.56 | 0.4 | 0.4 | 0.84 | 0.60 | 0.4 |
| 8-271-004 | M10 | 0.9 | 1.8 | 0.6 | 1.2 | 0.84 | 0.6 | 0.6 | 1.26 | 0.90 | 0.6 |
| 8-271-006 | M12 | 1.2 | 2.4 | 0.7 | 1.4 | 0.98 | 0.7 | 0.7 | 1.47 | 1.05 | 0.7 |
| 8-271-013 | M16 | 2.6 | 5.2 | 1.5 | 3.0 | 2.10 | 1.5 | 1.5 | 3.15 | 2.25 | 1.5 |
| 8-271-020 | M20 | 4.0 | 8.0 | 2.5 | 5.0 | 3.50 | 2.5 | 2.5 | 5.25 | 3.75 | 2.5 |
| 8-271-035 | M24 | 7.0 | 14.0 | 4.0 | 8.0 | 5.60 | 4.0 | 4.0 | 8.40 | 6.00 | 4.0 |
| 8-271-060 | M30 | 10.0 | 20.0 | 6.0 | 12.0 | 8.40 | 6.0 | 6.0 | 12.60 | 9.00 | 6.0 |
| 8-271-080 | M36 | 15.0 | 30.0 | 10.0 | 20.0 | 14.00 | 10.0 | 10.0 | 21.00 | 15.00 | 10.0 |
| 8-271-120 | M42 | 17.0 | 34.0 | 13.0 | 26.0 | 18.20 | 13.0 | 13.0 | 27.30 | 19.50 | 13.0 |
| 8-271-130 | M48 | 18.0 | 36.0 | 14.0 | 28.0 | 19.60 | 14.0 | 14.0 | 29.40 | 21.00 | 14.0 |
| 8-271-140 | M52 | 25.0 | 50.0 | 20.0 | 40.0 | 28.00 | 20.0 | 20.0 | 42.00 | 30.00 | 20.0 |
| 8-271-160 | M56 | 28.0 | 56.0 | 20.0 | 40.0 | 28.00 | 20.0 | 20.0 | 42.00 | 30.00 | 20.0 |
| 8-271-161 | M64 | 28.0 | 56.0 | 20.0 | 40.0 | 28.00 | 20.0 | 20.0 | 42.00 | 30.00 | 20.0 |
| 8-271-310 | M72 | 50.0 | 100.0 | 40.0 | 80.0 | 56.00 | 40.0 | 40.0 | 84.00 | 60.00 | 40.0 |
| 8-271-350 | M80 | 50.0 | 100.0 | 40.0 | 80.0 | 56.00 | 40.0 | 40.0 | 84.00 | 60.00 | 40.0 |
| 8-271-400 | M90 | 50.0 | 100.0 | 40.0 | 80.0 | 56.00 | 40.0 | 40.0 | 84.00 | 60.00 | 40.0 |

* Please refer to 8-251 table for specification \geq M72

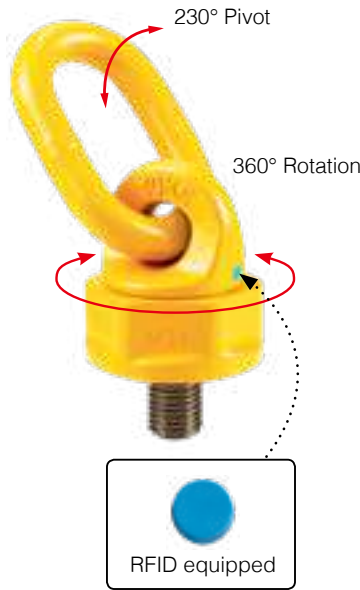
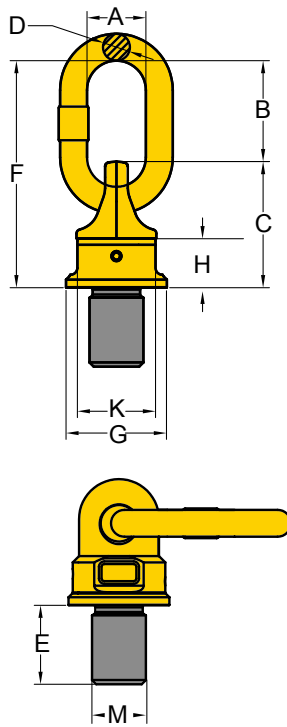

- Pivots to 230°, rotates through 360° due to its unique ball bearing design.
- Manufactured from forged alloy steel, quenched and tempered.
- Tested in accordance with EN1677-4.
- Load rated parts are 100% magnaflux crack detected.
- Individual forged parts and batch code links to Test Certificate sheet.
- Bolts are UNC thread.
- Proof tested to 2.5 times the WLL.
- Fatigue rated to 20,000 cycles at 1.5 times the WLL.
- All YOKE Lifting points meet or exceed all the requirements of ASME B30.26.
- Easy to attach or dismantle due to the forged hexagon shaped body of the Swivel Point.
- Capable of rotating under load. Do not turn continuously in 90 degree direction at full load.

Swivel Point

UNC Thread (8-272)



| Item No. | Working Load Limit | Thread version | | | | Dimensions | | | | | | | Torque | | N.W. |
|-----------|--------------------|----------------|------|--------|------|------------|------|------|-------|------|------|------|--------|------|------|
| | | M | E | TPI | G | C | K | H | F | D | B | A | in | lbs | |
| | tonnes | inch | inch | | | | | inch | | | | | Nm | | |
| 8-272-006 | 0.7 | 1/2 | 0.75 | 13UNC | 1.57 | 1.77 | 1.42 | 0.71 | 3.74 | 0.39 | 1.97 | 1.38 | 15 | 0.7 | |
| 8-272-013 | 1.5 | 5/8 | 0.94 | 11UNC | 1.81 | 2.13 | 1.61 | 0.87 | 4.09 | 0.51 | 1.97 | 1.42 | 45 | 1.2 | |
| 8-272-018 | 2.0 | 3/4 | 1.13 | 10UNC | 1.81 | 2.68 | 1.61 | 0.87 | 4.09 | 0.51 | 1.97 | 1.42 | 45 | 1.2 | |
| 8-272-020 | 2.5 | 7/8 | 1.31 | 9UNC | 2.44 | 2.68 | 2.17 | 1.14 | 4.80 | 0.51 | 2.13 | 1.42 | 100 | 2.2 | |
| 8-272-035 | 4.0 | 1 | 1.50 | 8UNC | 3.07 | 3.46 | 2.76 | 1.42 | 6.06 | 0.75 | 2.60 | 1.61 | 190 | 4.8 | |
| 8-272-060 | 6.0 | 1 1/4 | 1.88 | 7UNC | 3.54 | 4.72 | 3.15 | 1.89 | 8.11 | 0.87 | 3.39 | 1.97 | 270 | 9.9 | |
| 8-272-080 | 10.0 | 1 1/2 | 2.25 | 6UNC | 3.54 | 4.72 | 3.15 | 1.89 | 8.11 | 0.87 | 3.39 | 1.97 | 270 | 10.0 | |
| 8-272-120 | 13.0 | 1 3/4 | 2.63 | 5UNC | 3.86 | 4.80 | 3.31 | 1.97 | 9.25 | 0.98 | 4.33 | 2.64 | 350 | 12.1 | |
| 8-272-130 | 14.0 | 2 | 3.00 | 4.5UNC | 3.86 | 4.80 | 3.31 | 1.97 | 9.25 | 0.98 | 4.33 | 2.64 | 350 | 13.5 | |
| 8-272-140 | 20.0 | 2 1/4 | 3.38 | 4.5UNC | 4.72 | 5.91 | 3.70 | 2.36 | 10.63 | 1.26 | 4.72 | 2.83 | 350 | 23.1 | |
| 8-272-160 | 20.0 | 2 1/2 | 3.75 | 4UNC | 4.72 | 5.91 | 3.70 | 2.36 | 10.63 | 1.26 | 4.72 | 2.83 | 350 | 23.5 | |

* Design Factor 4:1

* Please refer to 8-252 table for specification \geq 3-4UNC.



| Kind of attachment | | | | | | | | | | | |
|--------------------|----------------|--------|------|------|------|-------|-----------|---------|---------|-----------|---------|
| Number of legs | Load direction | 1 | 2 | 1 | 2 | 2 | 2 | 2 | 3-4 | 3-4 | 3-4 |
| Item No. | Thread | 0° | 0° | 90° | 90° | 0-45° | 45° - 60° | unsymm. | 0 - 45° | 45° - 60° | unsymm. |
| | | WLL(t) | | | | | | | | | |
| 8-272-006 | 1/2 | 1.2 | 2.4 | 0.7 | 1.4 | 0.98 | 0.7 | 0.7 | 1.47 | 1.05 | 0.7 |
| 8-272-013 | 5/8 | 2.6 | 5.2 | 1.5 | 3.0 | 2.10 | 1.5 | 1.5 | 3.15 | 2.25 | 1.5 |
| 8-272-018 | 3/4 | 3.6 | 7.2 | 2.0 | 4.0 | 2.80 | 2.0 | 2.0 | 4.20 | 3.00 | 2.0 |
| 8-272-020 | 7/8 | 4.0 | 8.0 | 2.5 | 5.0 | 3.50 | 2.5 | 2.5 | 5.25 | 3.75 | 2.5 |
| 8-272-035 | 1 | 7.0 | 14.0 | 4.0 | 8.0 | 5.60 | 4.0 | 4.0 | 8.40 | 6.00 | 4.0 |
| 8-272-060 | 1 1/4 | 10.0 | 20.0 | 6.0 | 12.0 | 8.40 | 6.0 | 6.0 | 12.60 | 9.00 | 6.0 |
| 8-272-080 | 1 1/2 | 15.0 | 30.0 | 10.0 | 20.0 | 14.00 | 10.0 | 10.0 | 21.00 | 15.00 | 10.0 |
| 8-272-120 | 1 3/4 | 17.0 | 34.0 | 13.0 | 26.0 | 18.20 | 13.0 | 13.0 | 27.30 | 19.50 | 13.0 |
| 8-272-130 | 2 | 18.0 | 36.0 | 14.0 | 28.0 | 19.60 | 14.0 | 14.0 | 29.40 | 21.00 | 14.0 |
| 8-272-140 | 2 1/4 | 25.0 | 50.0 | 20.0 | 40.0 | 28.00 | 20.0 | 20.0 | 42.00 | 30.00 | 20.0 |
| 8-272-160 | 2 1/2 | 28.0 | 56.0 | 20.0 | 40.0 | 28.00 | 20.0 | 20.0 | 42.00 | 30.00 | 20.0 |

* Please refer to 8-252 table for specification \geq 3-4UNC.

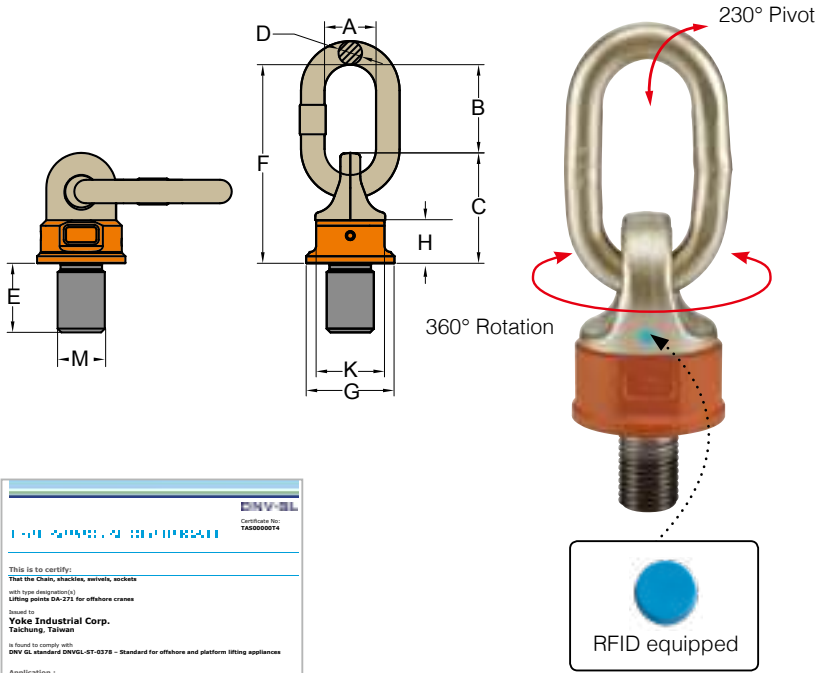

- Pivots to 230°, rotates through 360° due to its unique ball bearing design.
- Manufactured from forged alloy steel, quenched and tempered.
- Tested in accordance with EN 1677-4 and DNV GL-ST-0378.
- Certified by DNV GL-ST-0378.
- Load rated parts are 100% magnaflux crack detected.
- Individual forged parts and batch code links to Test Certificate sheet.
- Bolts are Metric thread.
- Proof tested to 2.5 times the WLL.
- Fatigue rated to 20,000 cycles at 1.5 times the WLL.
- All YOKE Lifting points meet or exceed all the requirements of ASME B30.26.
- Easy to attach or dismantle due to the forged hexagon shaped body of the DA Swivel Point.
- Capable of rotating under load. Do not turn continuously in 90 degree direction at full load.

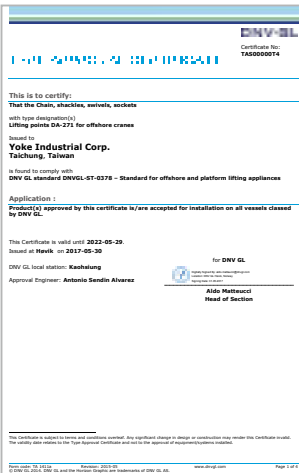

-40°C

DA Swivel Point

Metric Thread (DA-271)

DNV GL-ST-0378
(Offshore crane- Lifting Appliance)



| Item No. | Working Load Limit tonnes | Thread version | | | Dimensions (mm) | | | | | | | | Torque in Nm | N.W. kg |
|------------|------------------------------|----------------|----|----------------|-----------------|-----|----|----|-----|----|-----|----|-----------------|------------|
| | | M | E | Pitch DIN13 | G | C | K | H | F | D | B | A | | |
| DA-271-003 | 0.4 | M 8 | 12 | 1.25 | 35 | 40 | 30 | 16 | 72 | 8 | 32 | 29 | 10 | 0.2 |
| DA-271-004 | 0.6 | M 10 | 15 | 1.50 | 35 | 40 | 30 | 16 | 72 | 8 | 32 | 29 | 10 | 0.2 |
| DA-271-006 | 0.7 | M 12 | 18 | 1.75 | 40 | 45 | 36 | 18 | 95 | 10 | 50 | 35 | 10 | 0.3 |
| DA-271-013 | 1.5 | M 16 | 24 | 2.00 | 46 | 54 | 41 | 22 | 104 | 13 | 50 | 36 | 30 | 0.5 |
| DA-271-020 | 2.5 | M 20 | 30 | 2.50 | 62 | 68 | 55 | 29 | 122 | 13 | 54 | 36 | 70 | 1.0 |
| DA-271-035 | 4.0 | M 24 | 36 | 3.00 | 78 | 88 | 70 | 36 | 154 | 19 | 66 | 41 | 150 | 2.2 |
| DA-271-060 | 6.0 | M 30 | 45 | 3.50 | 90 | 120 | 80 | 48 | 206 | 22 | 86 | 50 | 350 | 4.5 |
| DA-271-080 | 10.0 | M 36 | 54 | 4.00 | 90 | 120 | 80 | 48 | 206 | 22 | 86 | 50 | 410 | 4.6 |
| DA-271-120 | 13.0 | M 42 | 63 | 4.50 | 98 | 122 | 84 | 50 | 235 | 25 | 110 | 67 | 550 | 5.5 |
| DA-271-130 | 14.0 | M 48 | 72 | 5.00 | 98 | 122 | 84 | 50 | 235 | 25 | 110 | 67 | 550 | 6.1 |
| DA-271-140 | 20.0 | M 52 | 78 | 5.00 | 120 | 150 | 94 | 60 | 270 | 32 | 120 | 72 | 750 | 10.5 |
| DA-271-160 | 20.0 | M 56 | 84 | 5.50 | 120 | 150 | 94 | 60 | 270 | 32 | 120 | 72 | 800 | 10.7 |
| DA-271-161 | 20.0 | M 64 | 96 | 6.00 | 120 | 150 | 94 | 60 | 270 | 32 | 120 | 72 | 800 | 11.6 |

* Design Factor 4:1



-40°C

| Kind of attachment | | | | | | | | | | | |
|--------------------|--------|--------|------|------|-------|-----------|---------|---------|-----------|---------|------|
| Number of legs | 1 | 2 | 1 | 2 | 2 | 2 | 2 | 3-4 | 3-4 | 3-4 | |
| Load direction | 0° | 0° | 90° | 90° | 0-45° | 45° - 60° | unsymm. | 0 - 45° | 45° - 60° | unsymm. | |
| Item No. | Thread | WLL(t) | | | | | | | | | |
| DA-271-003 | M 8 | 0.6 | 1.2 | 0.4 | 0.8 | 0.56 | 0.4 | 0.4 | 0.84 | 0.60 | 0.4 |
| DA-271-004 | M10 | 0.9 | 1.8 | 0.6 | 1.2 | 0.84 | 0.6 | 0.6 | 1.26 | 0.90 | 0.6 |
| DA-271-006 | M12 | 1.2 | 2.4 | 0.7 | 1.4 | 0.98 | 0.7 | 0.7 | 1.47 | 1.05 | 0.7 |
| DA-271-013 | M16 | 2.6 | 5.2 | 1.5 | 3.0 | 2.10 | 1.5 | 1.5 | 3.15 | 2.25 | 1.5 |
| DA-271-020 | M20 | 4.0 | 8.0 | 2.5 | 5.0 | 3.50 | 2.5 | 2.5 | 5.25 | 3.75 | 2.5 |
| DA-271-035 | M24 | 7.0 | 14.0 | 4.0 | 8.0 | 5.60 | 4.0 | 4.0 | 8.40 | 6.00 | 4.0 |
| DA-271-060 | M30 | 10.0 | 20.0 | 6.0 | 12.0 | 8.40 | 6.0 | 6.0 | 12.60 | 9.00 | 6.0 |
| DA-271-080 | M36 | 15.0 | 30.0 | 10.0 | 20.0 | 14.00 | 10.0 | 10.0 | 21.00 | 15.00 | 10.0 |
| DA-271-120 | M42 | 17.0 | 34.0 | 13.0 | 26.0 | 18.20 | 13.0 | 13.0 | 27.30 | 19.50 | 13.0 |
| DA-271-130 | M48 | 18.0 | 36.0 | 14.0 | 28.0 | 19.60 | 14.0 | 14.0 | 29.40 | 21.00 | 14.0 |
| DA-271-140 | M52 | 25.0 | 50.0 | 20.0 | 40.0 | 28.00 | 20.0 | 20.0 | 42.00 | 30.00 | 20.0 |
| DA-271-160 | M56 | 28.0 | 56.0 | 20.0 | 40.0 | 28.00 | 20.0 | 20.0 | 42.00 | 30.00 | 20.0 |
| DA-271-161 | M64 | 28.0 | 56.0 | 20.0 | 40.0 | 28.00 | 20.0 | 20.0 | 42.00 | 30.00 | 20.0 |

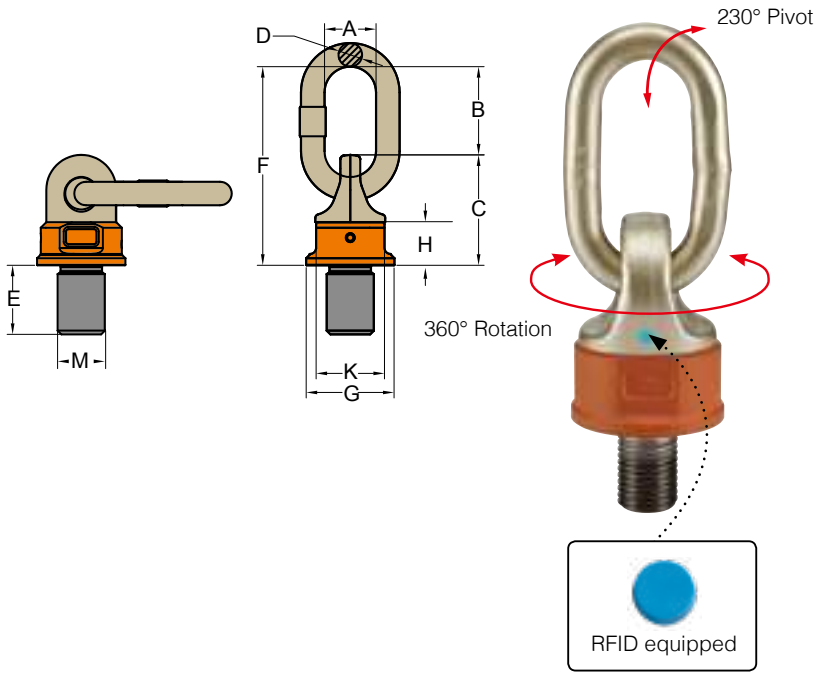

- Pivots to 230°, rotates through 360° due to its unique ball bearing design.
- Manufactured from forged alloy steel, quenched and tempered.
- Tested in accordance with EN 1677-4 y DNV GL-ST-0378.
- Load rated parts are 100% magnaflux crack detected.
- Individual forged parts and batch code links to Test Certificate sheet.
- Bolts are UNC thread.
- Proof tested to 2.5 times the WLL.
- Fatigue rated to 20,000 cycles at 1.5 times the WLL.
- All YOKE Lifting points meet or exceed all the requirements of ASME B30.26.
- Easy to attach or dismantle due to the forged hexagon shaped body of the DA Swivel Point.
- Capable of rotating under load. Do not turn continuously in 90 degree direction at full load.

-40°C

DA Swivel Point

UNC Thread (DA-272)

| Item No. | Working Load Limit | Thread version | | | Dimensions (mm) | | | | | | | | Torque in | N.W. |
|------------|--------------------|----------------|------|--------|-----------------|------|------|------|-------|------|------|------|-----------|------|
| | | M | E | TPI | G | C | K | H | F | D | B | A | | |
| | | tonnes | inch | inch | | | | inch | | | | | | |
| DA-272-006 | 0.7 | 1/2 | 0.75 | 13UNC | 1.57 | 1.77 | 1.42 | 0.71 | 3.74 | 0.39 | 1.97 | 1.38 | 15 | 0.7 |
| DA-272-013 | 1.5 | 5/8 | 0.94 | 11UNC | 1.81 | 2.13 | 1.61 | 0.87 | 4.09 | 0.51 | 1.97 | 1.42 | 45 | 1.2 |
| DA-272-018 | 2.0 | 3/4 | 1.13 | 10UNC | 1.81 | 2.68 | 1.61 | 0.87 | 4.09 | 0.51 | 1.97 | 1.42 | 45 | 1.2 |
| DA-272-020 | 2.5 | 7/8 | 1.31 | 9UNC | 2.44 | 2.68 | 2.17 | 1.14 | 4.80 | 0.51 | 2.13 | 1.42 | 100 | 2.2 |
| DA-272-035 | 4.0 | 1 | 1.50 | 8UNC | 3.07 | 3.46 | 2.76 | 1.42 | 6.06 | 0.75 | 2.60 | 1.61 | 190 | 4.8 |
| DA-272-060 | 6.0 | 1 1/4 | 1.88 | 7UNC | 3.54 | 4.72 | 3.15 | 1.89 | 8.11 | 0.87 | 3.39 | 1.97 | 270 | 9.9 |
| DA-272-080 | 10.0 | 1 1/2 | 2.25 | 6UNC | 3.54 | 4.72 | 3.15 | 1.89 | 8.11 | 0.87 | 3.39 | 1.97 | 270 | 10.0 |
| DA-272-120 | 13.0 | 1 3/4 | 2.63 | 5UNC | 3.86 | 4.80 | 3.31 | 1.97 | 9.25 | 0.98 | 4.33 | 2.64 | 350 | 12.1 |
| DA-272-130 | 14.0 | 2 | 3.00 | 4.5UNC | 3.86 | 4.80 | 3.31 | 1.97 | 9.25 | 0.98 | 4.33 | 2.64 | 350 | 13.5 |
| DA-272-140 | 20.0 | 2 1/4 | 3.38 | 4.5UNC | 4.72 | 5.91 | 3.70 | 2.36 | 10.63 | 1.26 | 4.72 | 2.83 | 350 | 23.1 |
| DA-272-160 | 20.0 | 2 1/2 | 3.75 | 4UNC | 4.72 | 5.91 | 3.70 | 2.36 | 10.63 | 1.26 | 4.72 | 2.83 | 350 | 23.5 |

* Design Factor 4:1



-40°C

| Kind of attachment | | | | | | | | | | | |
|--------------------|--------|--------|------|------|-------|-----------|---------|---------|-----------|---------|------|
| Number of legs | 1 | 2 | 1 | 2 | 2 | 2 | 2 | 3-4 | 3-4 | 3-4 | |
| Load direction | 0° | 0° | 90° | 90° | 0-45° | 45° - 60° | unsymm. | 0 - 45° | 45° - 60° | unsymm. | |
| Item No. | Thread | WLL(t) | | | | | | | | | |
| DA-272-006 | 1/2 | 1.2 | 2.4 | 0.7 | 1.4 | 0.98 | 0.7 | 0.7 | 1.47 | 1.05 | 0.7 |
| DA-272-013 | 5/8 | 2.6 | 5.2 | 1.5 | 3.0 | 2.10 | 1.5 | 1.5 | 3.15 | 2.25 | 1.5 |
| DA-272-018 | 3/4 | 3.6 | 7.2 | 2.0 | 4.0 | 2.80 | 2.0 | 2.0 | 4.20 | 3.00 | 2.0 |
| DA-272-020 | 7/8 | 4.0 | 8.0 | 2.5 | 5.0 | 3.50 | 2.5 | 2.5 | 5.25 | 3.75 | 2.5 |
| DA-272-035 | 1 | 7.0 | 14.0 | 4.0 | 8.0 | 5.60 | 4.0 | 4.0 | 8.40 | 6.00 | 4.0 |
| DA-272-060 | 1 1/4 | 10.0 | 20.0 | 6.0 | 12.0 | 8.40 | 6.0 | 6.0 | 12.60 | 9.00 | 6.0 |
| DA-272-080 | 1 1/2 | 15.0 | 30.0 | 10.0 | 20.0 | 14.00 | 10.0 | 10.0 | 21.00 | 15.00 | 10.0 |
| DA-272-120 | 1 3/4 | 17.0 | 34.0 | 13.0 | 26.0 | 18.20 | 13.0 | 13.0 | 27.30 | 19.50 | 13.0 |
| DA-272-130 | 2 | 18.0 | 36.0 | 14.0 | 28.0 | 19.60 | 14.0 | 14.0 | 29.40 | 21.00 | 14.0 |
| DA-272-140 | 2 1/4 | 25.0 | 50.0 | 20.0 | 40.0 | 28.00 | 20.0 | 20.0 | 42.00 | 30.00 | 20.0 |
| DA-272-160 | 2 1/2 | 28.0 | 56.0 | 20.0 | 40.0 | 28.00 | 20.0 | 20.0 | 42.00 | 30.00 | 20.0 |

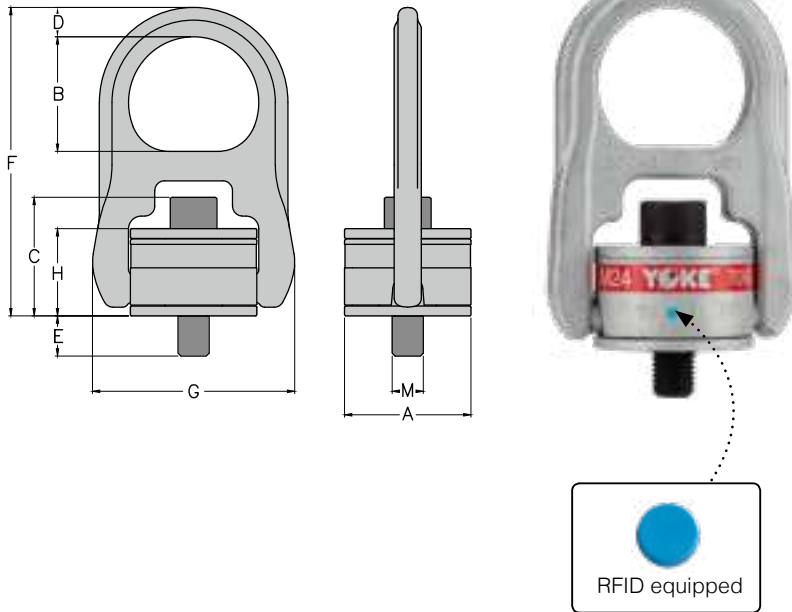

- Rotates through 360° and pivots 180°, and simultaneously allows lifting from any direction.
- Manufactured from forged alloy steel, quenched and tempered.
- Manufactured and tested in accordance with EN1677-1.
- Load rated parts are 100% magnaflux crack detected.
- Individual forged parts and cap screw are traceable to Test Certification.
- Bolts are Metric thread.
- Proof tested to 2.5 times the WLL.
- Fatigue rated to 20,000 cycles at 1.5 times the WLL.
- All YOKE Lifting points meet or exceed all the requirements of ASME B30.26.
- Quick and simple assembly, just a tapped hole is required

» Taiwan Patent
» China Patent

Hoist Ring





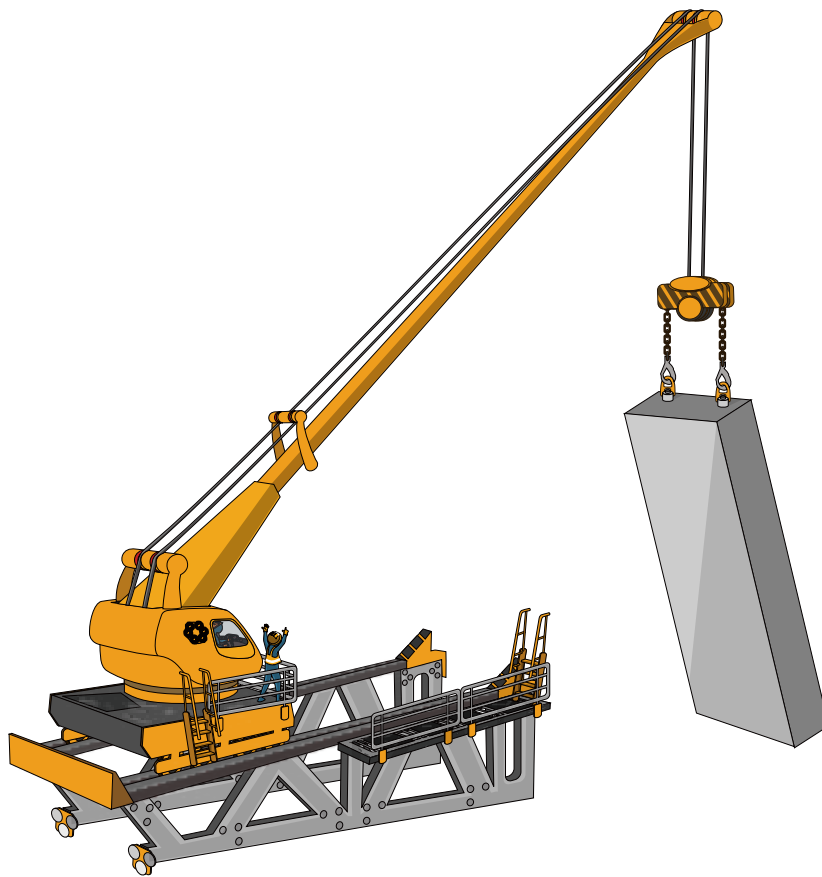

with Alloy Steel Washer
Metric Thread (8-203)

| Item No. | Working Load Limit | | Thread version | | | Dimensions | | | | | | | Torque in | N.W. |
|--------------|--------------------|-------|----------------|-----|-------|------------|-----|-----|----|-----|-----|----|-----------|------|
| | tonnes | | M | E | Pitch | A | B | C | D | F | G | H | Nm | kg |
| | 5 : 1 | 4 : 1 | mm | | DIN13 | | | | mm | | | | | |
| 8-203-004 | 0.40 | 0.50 | M 8 | 17 | 1.25 | 40 | 41 | 41 | 9 | 102 | 65 | 33 | 10 | 0.4 |
| 8-203-005 | 0.45 | 0.55 | M10 | 11 | 1.50 | 40 | 41 | 43 | 9 | 102 | 65 | 33 | 16 | 0.5 |
| § 8-203-005L | 0.45 | 0.55 | M10 | 26 | 1.50 | 40 | 41 | 43 | 9 | 102 | 65 | 33 | 16 | 0.5 |
| 8-203-010 | 1.05 | 1.30 | M12 | 15 | 1.75 | 65 | 58 | 57 | 15 | 158 | 105 | 45 | 38 | 1.7 |
| § 8-203-010L | 1.05 | 1.30 | M12 | 30 | 1.75 | 65 | 58 | 57 | 15 | 158 | 105 | 45 | 38 | 1.7 |
| 8-203-019 | 1.90 | 2.40 | M16 | 20 | 2.00 | 65 | 58 | 61 | 15 | 158 | 105 | 45 | 81 | 1.8 |
| § 8-203-019L | 1.90 | 2.40 | M16 | 35 | 2.00 | 65 | 58 | 61 | 15 | 158 | 105 | 45 | 81 | 1.8 |
| 8-203-021 | 2.15 | 2.70 | M20 | 25 | 2.50 | 65 | 58 | 65 | 15 | 158 | 105 | 45 | 136 | 1.8 |
| § 8-203-021L | 2.15 | 2.70 | M20 | 45 | 2.50 | 65 | 58 | 65 | 15 | 158 | 105 | 45 | 136 | 1.9 |
| 8-203-030 | 3.00 | 3.75 | M20 | 25 | 2.50 | 85 | 73 | 74 | 22 | 204 | 134 | 54 | 136 | 4.0 |
| § 8-203-030L | 3.00 | 3.75 | M20 | 45 | 2.50 | 85 | 73 | 74 | 22 | 204 | 134 | 54 | 136 | 5.2 |
| 8-203-042 | 4.20 | 5.25 | M24 | 26 | 3.00 | 85 | 73 | 78 | 22 | 204 | 134 | 54 | 312 | 4.2 |
| § 8-203-042L | 4.20 | 5.25 | M24 | 56 | 3.00 | 85 | 73 | 78 | 22 | 204 | 134 | 54 | 312 | 4.3 |
| 8-203-070 | 7.00 | 8.75 | M30 | 81 | 3.50 | 100 | 80 | 77 | 25 | 218 | 160 | 58 | 637 | 6.6 |
| 8-203-110 | 11.00 | 13.75 | M36 | 76 | 4.00 | 120 | 106 | 108 | 36 | 308 | 220 | 85 | 1005 | 15.0 |
| 8-203-125 | 12.50 | 15.60 | M42 | 95 | 4.50 | 120 | 106 | 111 | 36 | 308 | 220 | 85 | 1005 | 16.0 |
| 8-203-135 | 13.50 | 16.90 | M48 | 105 | 5.00 | 120 | 106 | 115 | 36 | 308 | 220 | 85 | 1350 | 16.0 |

* Design Factor 4:1

§ Long Bolts are designed for soft metal work piece.
Surface Treatment: The Dacromet original silver color.

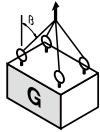
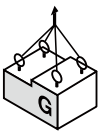

| Kind of attachment |     | |   | |   | | | | | | |
|--------------------|---|----------------|---|--------|---|-------|-------|-------|-------|-------|-------|
| | Number of legs | Load direction | Item No. | Thread | WLL(t) | | | | | | |
| 8-203-004 | M 8 | 0.50 | 1.0 | 0.50 | 1.0 | 0.70 | 0.50 | 0.50 | 1.05 | 0.75 | 0.50 |
| 8-203-005 | M10 | 0.55 | 1.1 | 0.55 | 1.1 | 0.77 | 0.55 | 0.55 | 1.16 | 0.83 | 0.55 |
| 8-203-010 | M12 | 1.30 | 2.6 | 1.30 | 2.6 | 1.82 | 1.30 | 1.30 | 2.73 | 1.95 | 1.30 |
| 8-203-019 | M16 | 2.40 | 4.8 | 2.40 | 4.8 | 3.36 | 2.40 | 2.40 | 5.04 | 3.60 | 2.40 |
| 8-203-021 | M20 | 2.70 | 5.4 | 2.70 | 5.4 | 3.78 | 2.70 | 2.70 | 5.67 | 4.05 | 2.70 |
| 8-203-030 | M20 | 3.75 | 7.5 | 3.75 | 7.5 | 5.25 | 3.75 | 3.75 | 7.88 | 5.63 | 3.75 |
| 8-203-042 | M24 | 5.25 | 10.5 | 5.25 | 10.5 | 7.35 | 5.25 | 5.25 | 11.03 | 7.88 | 5.25 |
| 8-203-070 | M30 | 8.75 | 17.5 | 8.75 | 17.5 | 12.25 | 8.75 | 8.75 | 18.38 | 13.13 | 8.75 |
| 8-203-110 | M36 | 13.75 | 27.5 | 13.75 | 27.5 | 19.25 | 13.75 | 13.75 | 28.88 | 20.63 | 13.75 |
| 8-203-125 | M42 | 15.60 | 31.2 | 15.60 | 31.2 | 21.84 | 15.60 | 15.60 | 32.76 | 23.40 | 15.60 |
| 8-203-135 | M48 | 16.90 | 33.8 | 16.90 | 33.5 | 23.66 | 16.90 | 16.90 | 35.49 | 25.35 | 16.90 |

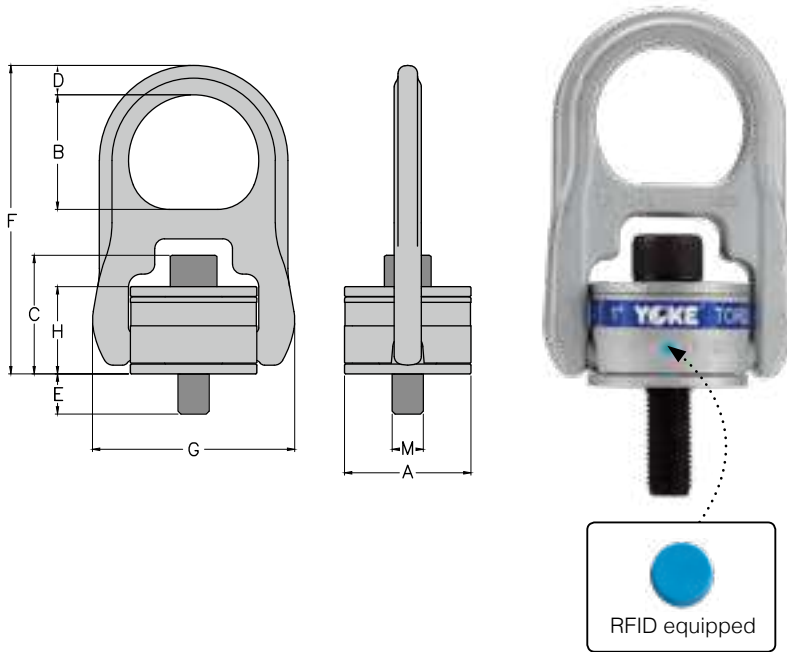

- Rotates through 360° and pivots 180°, and simultaneously allows lifting from any direction.
- Manufactured from forged alloy steel, quenched and tempered.
- Manufactured and tested in accordance with EN1677-1.
- Load rated parts are 100% magnaflux crack detected.
- Individual forged parts and cap screw are traceable to Test Certification.
- Bolts are UNC thread.
- Proof tested to 2.5 times the WLL.
- Fatigue rated to 20,000 cycles at 1.5 times the WLL.
- All YOKE Lifting points meet or exceed all the requirements of ASME B30.26.
- Quick and simple assembly, just a tapped hole is required.

» Taiwan Patent
» China Patent

Hoist Ring

with Alloy Steel Washer

UNC Thread (8-204)

| Item No. | Working Load Limit | Thread version | | | Dimensions | | | | | | | Torque in | N.W. |
|------------|--------------------|----------------|------|--------|------------|------|------|------|-------|------|------|-----------|------|
| | | M | E | TPI | A | B | C | D | F | G | H | | |
| | lbs | inch | inch | | | | | | | | | ft.lbs | lbs |
| 8-204-004 | 800 | 5/16 | 0.71 | 18UNC | 1.57 | 1.61 | 1.61 | 0.35 | 4.02 | 2.56 | 1.29 | 7 | 0.9 |
| 8-204-005 | 1000 | 3/8 | 0.71 | 16UNC | 1.57 | 1.61 | 1.69 | 0.35 | 4.02 | 2.56 | 1.29 | 12 | 0.9 |
| 8-204-010 | 2500 | 1/2 | 0.75 | 13UNC | 2.56 | 2.32 | 2.24 | 0.59 | 6.26 | 4.13 | 1.77 | 28 | 3.7 |
| 8-204-010L | 2500 | 1/2 | 1.26 | 13UNC | 2.56 | 2.32 | 2.24 | 0.59 | 6.26 | 4.13 | 1.77 | 28 | 3.7 |
| 8-204-019 | 4000 | 5/8 | 0.74 | 11UNC | 2.56 | 2.32 | 2.38 | 0.59 | 6.26 | 4.13 | 1.77 | 60 | 4.0 |
| 8-204-019L | 4000 | 5/8 | 1.75 | 11UNC | 2.56 | 2.32 | 2.38 | 0.59 | 6.26 | 4.13 | 1.77 | 60 | 4.0 |
| 8-204-021 | 5000 | 3/4 | 1.24 | 10UNC | 2.56 | 2.32 | 2.51 | 0.59 | 6.26 | 4.13 | 1.77 | 100 | 4.0 |
| 8-204-021L | 5000 | 3/4 | 1.73 | 10UNC | 2.56 | 2.32 | 2.51 | 0.59 | 6.26 | 4.13 | 1.77 | 100 | 4.2 |
| 8-204-030 | 7000 | 3/4 | 0.87 | 10UNC | 3.35 | 2.87 | 2.87 | 0.87 | 8.03 | 5.28 | 2.13 | 100 | 8.8 |
| 8-204-030L | 7000 | 3/4 | 1.87 | 10UNC | 3.35 | 2.87 | 2.87 | 0.87 | 8.03 | 5.28 | 2.13 | 100 | 9.5 |
| 8-204-042 | 8000 | 7/8 | 1.38 | 9UNC | 3.35 | 2.87 | 3.07 | 0.87 | 8.03 | 5.28 | 2.13 | 160 | 9.3 |
| 8-204-042L | 8000 | 7/8 | 2.37 | 9UNC | 3.35 | 2.87 | 3.07 | 0.87 | 8.03 | 5.28 | 2.13 | 160 | 9.7 |
| 8-204-045 | 10000 | 1 | 1.38 | 8UNC | 3.35 | 2.87 | 3.07 | 0.87 | 8.03 | 5.28 | 2.13 | 230 | 9.5 |
| 8-204-045L | 10000 | 1 | 2.37 | 8UNC | 3.35 | 2.87 | 3.07 | 0.87 | 8.03 | 5.28 | 2.13 | 230 | 10.1 |
| 8-204-070 | 15000 | 1 1/4 | 2.25 | 7UNC | 3.95 | 3.15 | 3.06 | 1 | 8.58 | 6.3 | 2.27 | 470 | 14.5 |
| 8-204-125 | 24000 | 1 1/2 | 2.17 | 6UNC | 4.72 | 4.17 | 4.29 | 1.41 | 12.09 | 8.66 | 3.36 | 800 | 35.2 |
| 8-204-135 | 30000 | 2 | 3.01 | 4.5UNC | 4.72 | 4.17 | 4.54 | 1.41 | 12.09 | 8.66 | 3.36 | 1100 | 35.2 |

* Design Factor 5:1
Surface Treatment: The Dacromet original silver color.

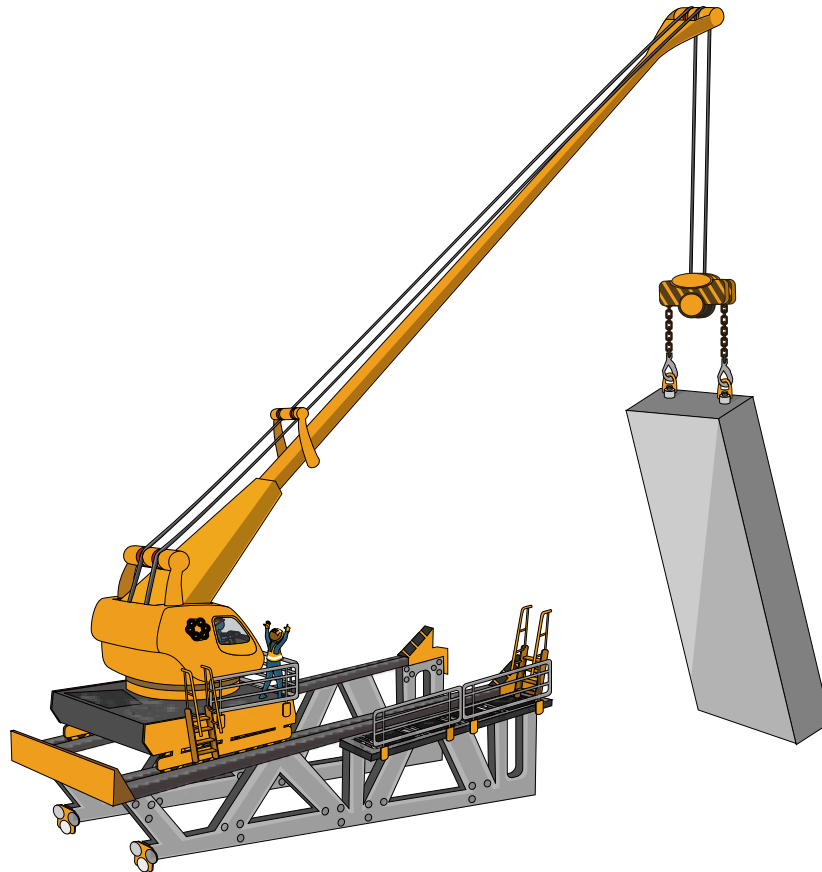

| Kind of attachment | | | | | | | | | | | |
|--------------------|--------|--------|-------|-------|-------|-------|-----------|---------|---------|-----------|---------|
| Number of legs | | 1 | 2 | 1 | 2 | 2 | 2 | 2 | 3-4 | 3-4 | 3-4 |
| Load direction | | 0° | 0° | 90° | 90° | 0-45° | 45° - 60° | unsymm. | 0 - 45° | 45° - 60° | unsymm. |
| Item No. | Thread | WLL(t) | | | | | | | | | |
| 8-204-004 | 5/16 | 0.36 | 0.72 | 0.36 | 0.72 | 0.50 | 0.36 | 0.36 | 0.76 | 0.54 | 0.36 |
| 8-204-005 | 3/8 | 0.45 | 0.90 | 0.45 | 0.90 | 0.63 | 0.45 | 0.45 | 0.95 | 0.68 | 0.45 |
| 8-204-010 | 1/2 | 1.10 | 2.20 | 1.10 | 2.20 | 1.54 | 1.10 | 1.10 | 2.31 | 1.65 | 1.10 |
| 8-204-019 | 5/8 | 1.80 | 3.60 | 1.80 | 3.60 | 2.52 | 1.80 | 1.80 | 3.78 | 2.70 | 1.80 |
| 8-204-021 | 3/4 | 2.20 | 4.40 | 2.20 | 4.40 | 3.08 | 2.20 | 2.20 | 4.62 | 3.30 | 2.20 |
| 8-204-030 | 3/4 | 3.10 | 6.20 | 3.10 | 6.20 | 4.34 | 3.10 | 3.10 | 6.51 | 4.65 | 3.10 |
| 8-204-042 | 7/8 | 3.60 | 7.20 | 3.60 | 7.20 | 5.04 | 3.60 | 3.60 | 7.56 | 5.40 | 3.60 |
| 8-204-045 | 1 | 4.50 | 9.00 | 4.50 | 9.00 | 6.30 | 4.50 | 4.50 | 9.45 | 6.75 | 4.50 |
| 8-204-070 | 1 1/4 | 6.80 | 13.60 | 6.80 | 13.60 | 9.52 | 6.80 | 6.80 | 14.28 | 10.20 | 6.80 |
| 8-204-125 | 1 1/2 | 10.90 | 21.80 | 10.90 | 21.80 | 15.26 | 10.90 | 10.90 | 22.89 | 16.35 | 10.90 |
| 8-204-135 | 2 | 13.60 | 27.20 | 13.60 | 27.20 | 19.04 | 13.60 | 13.60 | 28.56 | 20.40 | 13.60 |



Y PSA

Anchor Point for Personal Protective Equipment



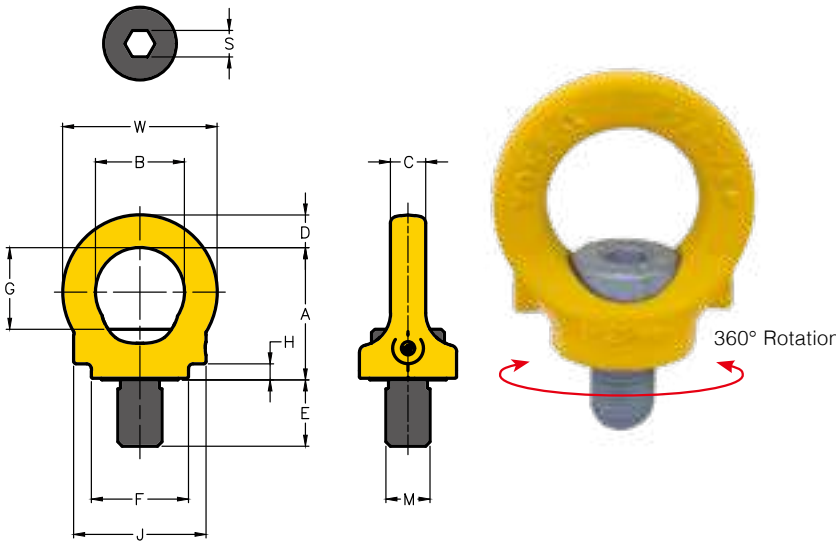

Anchor Point for Personal Protective Equipment

- Rotates through 360° adjustable in the direction of the load.
 - Manufactured from forged alloy steel, quenched and tempered.
 - Manufactured and tested in accordance with EN795 or TS16415.
 - Certified by PSA of DGUV.
 - Load rated parts are 100% magnaflux crack detected.
 - Individual forged parts and cap screw are traceable to Test Certification.
 - Passed 22.2 KN/person Load testing.
 - Passed 100kg or 150 kg dynamic fall testing (EU standard is 100 kg).
 - Meets all requirements of the German BG BAU (Employer's insurance association of the building industry).
 - Meets all requirements of DIN EN795, DIN EN50308, OSHA1926.502.
 - Acc. to DIN EN 365 including statement for the number of load bearing persons is 1-2 persons.
 - Correspond to the European Directive for "personnel protection equipment" (89/686/ EWG).
 - YOKE yellow powder coating for high visibility.
 - PSA - Lifting point to be as an anchor point for personal protective equipment.
- » Taiwan Patent » Australian Patent
 » China Patent » Mexican Patent
 » French Patent » Japanese Patent

PSA-YEP

Metric (8-281)

| Item No. | Working Load Limit | Thread version | Dimensions(mm) | | | | | | | | | | | Torque | |
|-----------|--------------------|----------------|----------------|----|----|----|----|----|----|---|----|----|----|--------|-----|
| | | | M | A | B | C | D | E | F | G | H | J | S | W | Nm |
| 8-281-007 | 1 Pers | M12x1.75 | 45 | 30 | 10 | 11 | 18 | 33 | 29 | 5 | 45 | 8 | 52 | 10 | 0.2 |
| 8-281-015 | 1-2 Pers | M16x2.0 | 52 | 35 | 14 | 13 | 24 | 35 | 33 | 8 | 52 | 10 | 61 | 30 | 0.3 |
| 8-281-023 | 1-2 Pers | M20x2.5 | 60 | 40 | 16 | 15 | 30 | 44 | 37 | 7 | 60 | 12 | 70 | 70 | 0.6 |

PSA-YEP

Imperial (8-281)

| Item No. | Working Load Limit | Thread version | Dimensions(inch) | | | | | | | | | | | Torque | |
|-----------|--------------------|----------------|------------------|-----|-----|-----|-----|-----|-----|-----|-----|-----|-----|--------|---------|
| | | | M | A | B | C | D | E | F | G | H | J | S | W | ft. lbs |
| 8-281-007 | 1 Pers | M12x1.75 | 1.8 | 1.2 | 0.4 | 0.4 | 0.7 | 1.3 | 1.1 | 0.2 | 1.8 | 0.3 | 2.0 | 7.4 | 0.4 |
| 8-281-015 | 1-2 Pers | M16x2.0 | 2.0 | 1.4 | 0.6 | 0.5 | 0.9 | 1.4 | 1.3 | 0.3 | 2.0 | 0.4 | 2.4 | 22.1 | 0.7 |
| 8-281-023 | 1-2 Pers | M20x2.5 | 2.4 | 1.6 | 0.6 | 0.6 | 1.2 | 1.7 | 1.5 | 0.3 | 2.4 | 0.5 | 2.8 | 51.7 | 1.3 |

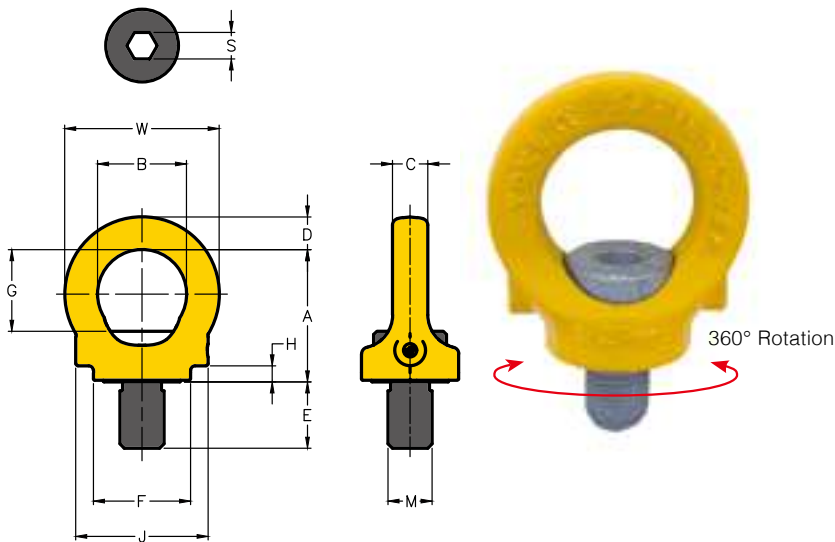

Anchor Point for Personal Protective Equipment

- Rotates through 360° adjustable in the direction of the load.
- Manufactured from forged stainless steel.
- Manufactured and tested in accordance with EN795 or TS16415.
- Load rated parts are 100% magnaflux crack detected.
- Individual forged parts and cap screw are traceable to Test Certification.
- Passed 22.2KN/person load testing.
- Passed 100kg or 150 kg dynamic fall testing (EU standard is 100 kg).
- Meets all requirements of the German BG BAU (Employer's insurance association of the building industry).
- Meets all requirements of DIN EN795, DIN EN50308, OSHA1926.502.
- Acc. to DIN EN 365 including statement for the number of load bearing persons is 1-2 persons.
- Corresponds to the European Directive for "personnel protection equipment" (89/686/ EWG).
- YOKE yellow powder coating for high visibility.
- Suitable for permanently outdoor application.
- PSA-INOX Lifting point to be as an anchor point for personal protective equipment.

- » Taiwan Patent
- » China Patent
- » French Patent
- » Australian Patent
- » Mexican Patent
- » Japanese Patent

PSA-INOX-YEP

Metric (8-285) stainless steel

| Item No. | Working Load Limit | Thread version | Dimensions(mm) | | | | | | | | | | | Torque in | | N.W. |
|-----------|--------------------|----------------|----------------|----|----|----|----|----|----|---|----|----|----|-----------|-----|------|
| | | | M | A | B | C | D | E | F | G | H | J | S | W | Nm | |
| 8-285-007 | 1 Pers | M12x1.75 | 45 | 30 | 10 | 11 | 18 | 33 | 29 | 5 | 45 | 8 | 52 | 10 | 0.2 | |
| 8-285-015 | 1-2 Pers | M16x2.0 | 52 | 35 | 14 | 13 | 24 | 35 | 33 | 5 | 52 | 10 | 61 | 30 | 0.3 | |
| 8-285-023 | 1-2 Pers | M20x2.5 | 60 | 40 | 16 | 15 | 30 | 44 | 37 | 7 | 60 | 12 | 70 | 70 | 0.6 | |

PSA-INOX-YEP

Imperial (8-285) stainless steel

| Item No. | Working Load Limit | Thread version | Dimensions(inch) | | | | | | | | | | | Torque in | | N.W. |
|-----------|--------------------|----------------|------------------|-----|-----|-----|-----|-----|-----|-----|-----|-----|-----|-----------|---------|------|
| | | | M | A | B | C | D | E | F | G | H | J | S | W | ft. lbs | |
| 8-285-007 | 1 Pers | M12x1.75 | 1.8 | 1.2 | 0.4 | 0.4 | 0.7 | 1.3 | 1.1 | 0.2 | 1.8 | 0.3 | 2.0 | 7.4 | 0.4 | |
| 8-285-015 | 1-2 Pers | M16x2.0 | 2.0 | 1.4 | 0.6 | 0.5 | 0.9 | 1.4 | 1.3 | 0.2 | 2.0 | 0.4 | 2.4 | 22.1 | 0.7 | |
| 8-285-023 | 1-2 Pers | M20x2.5 | 2.4 | 1.6 | 0.6 | 0.6 | 1.2 | 1.7 | 1.5 | 0.3 | 2.4 | 0.5 | 2.8 | 51.7 | 1.3 | |

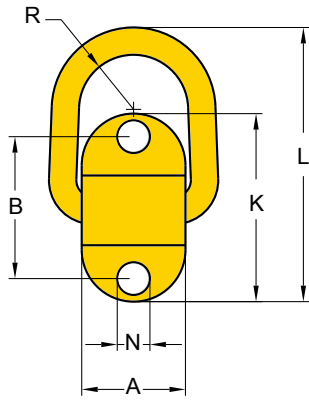

- Pivots 180° and allows side load lifting.
- Manufactured from forged alloy steel, quenched and tempered.
- Manufactured and tested in accordance with EN1677-1.
- Load rated parts are 100% magnaflux crack detected.
- Individual forged parts are traceable to Test Certification.
- Supplied without bolts; usage of Grade 10.9 or Grade 12.9 bolts is recommended.
- Proof tested to 2.5 times the WLL.
- All YOKE Lifting points meet or exceed all the requirements of ASME B30.26.

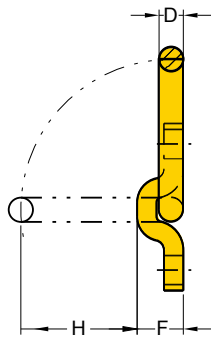

Bolt-on Tie Down.

Designed with spring, stop at any angle supplied without bolt (8-058)

| Item No. | Working Load Limit tonnes | Dimensions (mm) | | | | | | | | | Bolt size Thread | N.W. kg |
|----------|------------------------------|-----------------|-----|----|----|----|-----|-----|----|----|---------------------|------------|
| | | A | B | D | F | H | K | L | N | R | | |
| 8-058-1T | 1.0 | 50 | 72 | 14 | 27 | 55 | 98 | 139 | 14 | 24 | M12 | 0.7 |
| 8-058-3T | 3.0 | 58 | 84 | 17 | 34 | 53 | 114 | 147 | 18 | 29 | M16 | 1.1 |
| 8-058-5T | 5.0 | 64 | 117 | 22 | 46 | 74 | 160 | 206 | 23 | 33 | M20/M22 | 2.5 |

* Design factor 5:1

Bolt-on Tie Down.

Designed with spring, stop at any angle supplied without bolt (Imperial 8-058)

| Item No. | Working Load Limit tonnes | Dimensions (inch) | | | | | | | | | N.W. lbs |
|----------|------------------------------|-------------------|------|------|------|------|------|------|------|------|-------------|
| | | A | B | D | F | H | K | L | N | R | |
| 8-058-1T | 1.0 | 1.97 | 2.83 | 0.55 | 1.06 | 2.17 | 3.86 | 5.47 | 0.55 | 0.94 | 1.5 |
| 8-058-3T | 3.0 | 2.28 | 3.31 | 0.67 | 1.33 | 2.09 | 4.49 | 5.79 | 0.71 | 1.14 | 2.4 |
| 8-058-5T | 5.0 | 2.52 | 4.61 | 0.87 | 1.81 | 2.91 | 6.30 | 8.11 | 0.91 | 1.30 | 5.5 |

* Design factor 5:1



Weld-on Lifting Points





Weld-on Point

Classic Weld-on Point

Weld-on Ring

Weld-on Hook

Excavator Hook

Super Weld-on Point

8-057

8-0573

8-082

8-081

8-083

8-0575

Kind of attachment

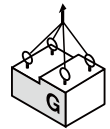
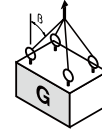
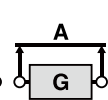
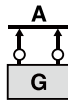
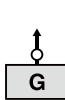

Number of legs

1

2

1

2

2

2

2

3-4

3-4

3-4

Load direction

0°

0°

90°

90°

0-45°

45° - 60°

unsymm.

0 - 45°

45° - 60°

unsymm.

Item No.

WLL(t)

| | | | | | | | | | | |
|-------------------|------|------|------|------|------|------|------|------|------|------|
| 8-0573-01 | 1.0 | 2.0 | 1.0 | 2.0 | 1.4 | 1.0 | 1.0 | 2.1 | 1.5 | 1.0 |
| 8-0573-03 | 3.0 | 6.0 | 3.0 | 6.0 | 4.2 | 3.0 | 3.0 | 6.3 | 4.5 | 3.0 |
| 8-0573-05 | 5.0 | 10.0 | 5.0 | 10.0 | 7.0 | 5.0 | 5.0 | 10.5 | 7.5 | 5.0 |
| 8-0573-08 | 8.0 | 16.0 | 8.0 | 16.0 | 11.2 | 8.0 | 8.0 | 16.8 | 12.0 | 8.0 |
| 8-0573-10 | 10.0 | 20.0 | 10.0 | 20.0 | 14.0 | 10.0 | 10.0 | 21.0 | 15.0 | 10.0 |
| 8-0573-20 | 20.0 | 40.0 | 20.0 | 40.0 | 28.0 | 20.0 | 20.0 | 42.0 | 30.0 | 20.0 |
| 8-0573-30 | 30.0 | 60.0 | 30.0 | 60.0 | 42.0 | 30.0 | 30.0 | 63.0 | 45.0 | 30.0 |
| 8-057-1T | 1.0 | 2.0 | 1.0 | 2.0 | 1.4 | 1.0 | 1.0 | 2.1 | 1.5 | 1.0 |
| 8-057-3T | 3.0 | 6.0 | 3.0 | 6.0 | 4.2 | 3.0 | 3.0 | 6.3 | 4.5 | 3.0 |
| 8-057-5T | 5.0 | 10.0 | 5.0 | 10.0 | 7.0 | 5.0 | 5.0 | 10.5 | 7.5 | 5.0 |
| 8-057-8T | 8.0 | 16.0 | 8.0 | 16.0 | 11.2 | 8.0 | 8.0 | 16.8 | 12.0 | 8.0 |
| 8-057-10T | 10.0 | 20.0 | 10.0 | 20.0 | 14.0 | 10.0 | 10.0 | 21.0 | 15.0 | 10.0 |
| 8-082-04 | 4.0 | 8.0 | 4.0 | 8.0 | 5.6 | 4.0 | 4.0 | 8.4 | 6.0 | 4.0 |
| 8-082-06 | 6.7 | 13.4 | 6.7 | 13.4 | 9.4 | 6.7 | 6.7 | 14.1 | 10.1 | 6.7 |
| 8-082-10 | 10.0 | 20.0 | 10.0 | 20.0 | 14.0 | 10.0 | 10.0 | 21.0 | 15.0 | 10.0 |
| 8-082-16 | 16.0 | 32.0 | 16.0 | 32.0 | 22.4 | 16.0 | 16.0 | 33.6 | 24.0 | 16.0 |
| 8-082-30 | 31.5 | 63.0 | 31.5 | 63.0 | 44.1 | 31.5 | 31.5 | 66.2 | 47.3 | 31.5 |
| 8-081-01/8-083-01 | 0.8 | 1.5 | 0.8 | 1.5 | 1.1 | 0.8 | 0.8 | 1.6 | 1.1 | 0.8 |
| 8-081-01/8-083-01 | 1.0 | 2.0 | 1.0 | 2.0 | 1.4 | 1.0 | 1.0 | 2.1 | 1.5 | 1.0 |
| 8-081-02/8-083-02 | 2.0 | 4.0 | 2.0 | 4.0 | 2.8 | 2.0 | 2.0 | 4.2 | 3.0 | 2.0 |
| 8-081-03/8-083-03 | 3.0 | 6.0 | 3.0 | 6.0 | 4.2 | 3.0 | 3.0 | 6.3 | 4.5 | 3.0 |
| 8-081-04/8-083-04 | 4.0 | 8.0 | 4.0 | 8.0 | 5.6 | 4.0 | 4.0 | 8.4 | 6.0 | 4.0 |
| 8-081-05/8-083-05 | 5.0 | 10.0 | 5.0 | 10.0 | 7.0 | 5.0 | 5.0 | 10.5 | 7.5 | 5.0 |
| 8-081-08/8-083-08 | 8.0 | 16.0 | 8.0 | 16.0 | 11.2 | 8.0 | 8.0 | 16.8 | 12.0 | 8.0 |
| 8-081-10/8-083-10 | 10.0 | 20.0 | 10.0 | 20.0 | 14.0 | 10.0 | 10.0 | 21.0 | 15.0 | 10.0 |
| 8-081-15/8-083-15 | 15.0 | 30.0 | 15.0 | 30.0 | 21.0 | 15.0 | 15.0 | 31.5 | 22.5 | 15.0 |
| 8-0575-015 | 1.5 | 3.0 | 1.5 | 3.0 | 2.1 | 1.5 | 1.5 | 3.2 | 2.3 | 1.5 |
| 8-0575-025 | 2.5 | 5.0 | 2.5 | 5.0 | 3.5 | 2.5 | 2.5 | 5.3 | 3.8 | 2.5 |
| 8-0575-040 | 4.0 | 8.0 | 4.0 | 8.0 | 5.6 | 4.0 | 4.0 | 8.4 | 6.0 | 4.0 |
| 8-0575-067 | 6.7 | 13.4 | 6.7 | 13.4 | 9.4 | 6.7 | 6.7 | 14.1 | 10.1 | 6.7 |
| 8-0575-100 | 10.0 | 20.0 | 10.0 | 20.0 | 14.0 | 10.0 | 10.0 | 21.0 | 15.0 | 10.0 |
| 8-0575-160 | 16.0 | 32.0 | 16.0 | 32.0 | 22.4 | 16.0 | 16.0 | 33.6 | 24.0 | 16.0 |





WELDING INSTRUCTIONS

The welding should only be carried out by qualified welder according to Standards, e.g. EN 287 or AWS.

Support material

- Material of the welding block is S355J2+N (1.0577+N, St 52-3N, B.S. 4360.50D, AISI 1019 etc.).
- Prior to welding, the contact areas must be free from impurities, oil, paint, rust, scale, etc., for example by grinding. If the surface is at all corroded, all rust must be completely removed from the weld area. Painted surface must be prepared in the same way.
- The steel support member must have a carbon content of no more than 0.40%.
- In ambient temperature of 10°C and below, pre-heating of the weld area prior to welding must be carried out.

Seam welding

- The welds must be sufficiently strong to take the required loads.
- Before starting the final weld pass, clean well the root pass to avoid inclusions.
- The complete welding operation must be carried out continuously so that the parts do not have time to cool.
- Effects of temperature
 - The complete construction can be annealed stress release at <math><600^{\circ}\text{C}</math> without reduction of WLL.
 - Do not rapidly cool the weld.
- A thorough inspection of the weld should be performed. No cracks, pitting, inclusions, notches or undercuts are allowed. If doubt exists, use a suitable NDT method, such as magnetic particle or liquid penetrant to verify.
- If repair is required, grind out the defect and re-weld using the original qualified procedure.

Welding materials

- Weld materials must have a minimum tensile strength of 70,000 PSI (such as AWS A5.1 E-7018), following the electrode manufacturer's recommendations. Reference information as below:

MIG arc welding:

- Wire diameter 0.8 - 1.2 as per DIN 8559-SG 3, AWS A 5.18.
- Important: do not weld in the open air during bad weather

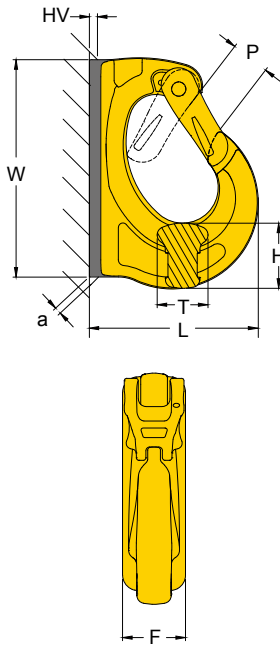

- Manufactured from forged alloy steel, quenched and tempered.
- Manufactured and tested in accordance with EN1677-1.
- Certified by DGUV GS-OA-15-03.
- Load rated parts are 100% magnaflux crack detected.
- Individual forged parts are traceable to Test Certification.
- All YOKE Lifting points meet or exceed all the requirements of ASME B30.26.
- WLL forged onto each product for quick and easy identification.
- Lugs designed to assist the welding process.

Excavator Hook

Metric (8-083)

| Item No. | Working Load Limit tonnes | Dimensions (mm) | | | | | | | | N.W. kg |
|------------|------------------------------|-----------------|----|-----|----|----|-----|----|----|------------|
| | | F | H | L | P | T | W | HV | a | |
| 8-083-0075 | 0.75 | 19 | 20 | 56 | 19 | 13 | 82 | 5 | 3 | 0.3 |
| 8-083-01 | 1.00 | 25 | 27 | 72 | 27 | 17 | 95 | 6 | 4 | 0.6 |
| 8-083-02 | 2.00 | 30 | 30 | 86 | 33 | 20 | 114 | 8 | 5 | 0.9 |
| 8-083-03 | 3.00 | 35 | 32 | 105 | 30 | 23 | 132 | 10 | 6 | 1.4 |
| 8-083-04 | 4.00 | 42 | 38 | 112 | 30 | 29 | 140 | 11 | 7 | 1.9 |
| 8-083-05 | 5.00 | 45 | 47 | 131 | 32 | 30 | 165 | 12 | 8 | 2.9 |
| 8-083-08 | 8.00 | 50 | 51 | 133 | 34 | 40 | 172 | 13 | 9 | 3.5 |
| 8-083-10 | 10.00 | 55 | 57 | 170 | 51 | 43 | 220 | 14 | 9 | 6.3 |
| 8-083-15 | 15.00 | 60 | 67 | 191 | 53 | 50 | 240 | 15 | 12 | 8.8 |

* Design factor 5:1
YOKE recommends that the working load limit should be reduced to meet any appropriate legislative requirements, if welding on to an excavator. Please contact your YOKE distributors for further information.

Excavator Hook

Imperial (8-083)

| Item No. | Working Load Limit tonnes | Dimensions (inch) | | | | | | | | N.W. lbs |
|------------|------------------------------|-------------------|------|------|------|------|------|------|------|-------------|
| | | F | H | L | P | T | W | HV | a | |
| 8-083-0075 | 0.75 | 0.75 | 0.79 | 2.20 | 0.75 | 0.51 | 3.21 | 0.20 | 0.12 | 0.6 |
| 8-083-01 | 1.00 | 0.98 | 1.06 | 2.83 | 1.06 | 0.67 | 3.74 | 0.24 | 0.16 | 1.2 |
| 8-083-02 | 2.00 | 1.18 | 1.18 | 3.39 | 1.30 | 0.79 | 4.49 | 0.31 | 0.20 | 2.0 |
| 8-083-03 | 3.00 | 1.38 | 1.26 | 4.13 | 1.18 | 0.91 | 5.20 | 0.39 | 0.24 | 3.1 |
| 8-083-04 | 4.00 | 1.65 | 1.50 | 4.41 | 1.18 | 1.14 | 5.51 | 0.43 | 0.28 | 4.3 |
| 8-083-05 | 5.00 | 1.77 | 1.85 | 5.16 | 1.26 | 1.18 | 6.50 | 0.47 | 0.31 | 6.3 |
| 8-083-08 | 8.00 | 1.97 | 2.01 | 5.24 | 1.34 | 1.57 | 6.77 | 0.51 | 0.35 | 7.7 |
| 8-083-10 | 10.00 | 2.17 | 2.24 | 6.69 | 2.01 | 1.69 | 8.66 | 0.55 | 0.35 | 14.0 |
| 8-083-15 | 15.00 | 2.36 | 2.64 | 7.52 | 2.09 | 1.97 | 9.45 | 0.59 | 0.47 | 19.3 |

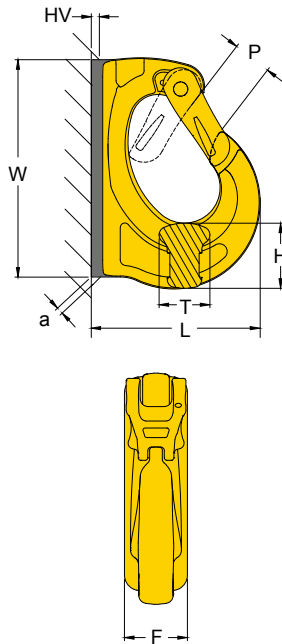

- Manufactured from forged alloy steel, quenched and tempered.
- Manufactured and tested in accordance with EN1677-1.
- Certified by DGUV GS-OA-15-03.
- Load rated parts are 100% magnaflux crack detected.
- Individual forged parts are traceable to Test Certification.
- All YOKE Lifting points meet or exceed all the requirements of ASME B30.26.
- WLL forged onto each product for quick and easy identification.
- Lugs designed to assist the welding process.

Weld-on Hook

Metric (8-081)

| Item No. | Working Load Limit tonnes | Dimensions (mm) | | | | | | | | N.W. kg |
|----------|------------------------------|-----------------|----|-----|----|----|-----|----|----|------------|
| | | F | H | L | P | T | W | HV | a | |
| 8-081-01 | 1.0 | 25 | 27 | 72 | 18 | 18 | 95 | 7 | 4 | 0.6 |
| 8-081-02 | 2.0 | 30 | 30 | 85 | 25 | 20 | 115 | 8 | 5 | 1.0 |
| 8-081-03 | 3.0 | 35 | 30 | 105 | 28 | 23 | 133 | 9 | 6 | 1.4 |
| 8-081-04 | 4.0 | 42 | 38 | 111 | 28 | 30 | 142 | 10 | 7 | 2.2 |
| 8-081-05 | 5.0 | 44 | 47 | 132 | 30 | 31 | 167 | 12 | 7 | 3.0 |
| 8-081-08 | 8.0 | 50 | 52 | 134 | 32 | 39 | 176 | 12 | 8 | 3.7 |
| 8-081-10 | 10.0 | 56 | 56 | 168 | 44 | 42 | 222 | 13 | 8 | 6.2 |
| 8-081-15 | 15.0 | 61 | 67 | 184 | 54 | 45 | 242 | 14 | 10 | 7.9 |

* Design factor 5:1

YOKE recommends that the working load limit should be reduced to meet any appropriate legislative requirements, if welding on to an excavator. Please contact your YOKE distributors for further information.

Weld-on Hook

Imperial (8-081)

| Item No. | Working Load Limit tonnes | Dimensions (inch) | | | | | | | | N.W. lbs |
|----------|------------------------------|-------------------|------|------|------|------|------|------|------|-------------|
| | | F | H | L | P | T | W | HV | a | |
| 8-081-01 | 1.0 | 0.98 | 1.06 | 2.83 | 0.71 | 0.71 | 3.74 | 0.28 | 0.16 | 1.3 |
| 8-081-02 | 2.0 | 1.18 | 1.18 | 3.35 | 0.98 | 0.79 | 4.53 | 0.31 | 0.20 | 2.2 |
| 8-081-03 | 3.0 | 1.38 | 1.18 | 4.13 | 1.10 | 0.91 | 5.24 | 0.35 | 0.24 | 3.1 |
| 8-081-04 | 4.0 | 1.65 | 1.50 | 4.37 | 1.10 | 1.18 | 5.55 | 0.39 | 0.28 | 4.4 |
| 8-081-05 | 5.0 | 1.73 | 1.81 | 5.20 | 1.18 | 1.22 | 6.57 | 0.47 | 0.28 | 6.6 |
| 8-081-08 | 8.0 | 1.97 | 2.13 | 5.28 | 1.26 | 1.54 | 6.89 | 0.47 | 0.31 | 8.4 |
| 8-081-10 | 10.0 | 2.20 | 2.20 | 6.61 | 1.73 | 1.65 | 8.74 | 0.51 | 0.31 | 13.9 |
| 8-081-15 | 15.0 | 2.40 | 2.64 | 7.24 | 2.13 | 1.77 | 9.49 | 0.55 | 0.39 | 17.4 |

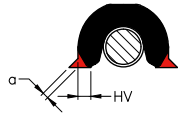
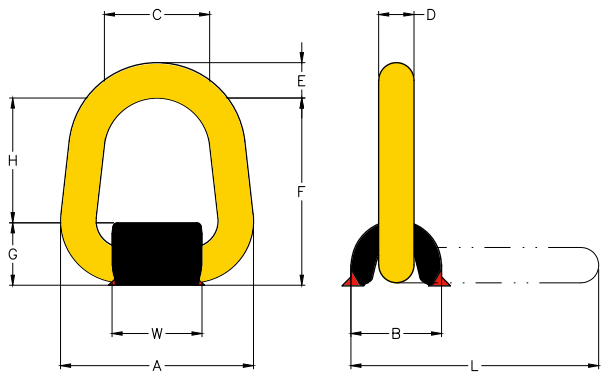

Classic

- Pivots through 180°.
- Manufactured from forged alloy steel, quenched and tempered.
- Manufactured and tested in accordance with EN1677-1.
- Load rated parts are 100% magnaflux crack detected.
- Individual forged parts are traceable to Test Certification.
- Proof tested to 2.5 times the WLL.
- All YOKE Lifting points meet or exceed all the requirements of ASME B30.26.
- WLL forged onto each product for quick and easy identification.
- Lugs designed to assist the welding process.
- Never apply load except in the same direction with the pivot direction.

Classic Weld-on Point

without Spring Designed

Metric (8-0573) & Imperial (8-0573)

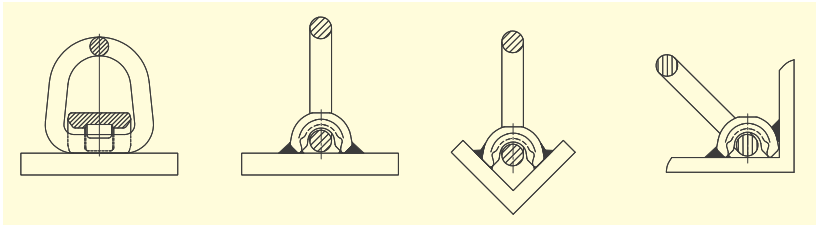

| Item No. | Working Load Limit tonnes* | Dimensions (mm) | | | | | | | | | | | N.W. | |
|-----------|-------------------------------|-----------------|-----|-----|----|----|-----|----|-----|-----|-----|----|------|------|
| | | A | B | C | D | E | F | G | H | L | W | HV | a | kg |
| 8-0573-01 | 1.0 | 83 | 41 | 48 | 14 | 14 | 86 | 27 | 58 | 109 | 50 | 5 | 3 | 0.5 |
| 8-0573-03 | 3.0 | 98 | 48 | 58 | 17 | 17 | 85 | 31 | 54 | 114 | 58 | 6 | 3 | 0.9 |
| 8-0573-05 | 5.0 | 120 | 63 | 66 | 22 | 22 | 118 | 41 | 77 | 157 | 64 | 7 | 3 | 1.3 |
| 8-0573-08 | 8.0 | 121 | 73 | 68 | 26 | 26 | 122 | 53 | 69 | 169 | 60 | 10 | 4 | 2.4 |
| 8-0573-10 | 10.0 | 146 | 73 | 82 | 20 | 30 | 141 | 53 | 88 | 191 | 75 | 10 | 4 | 2.8 |
| 8-0573-20 | 20.0** | 186 | 93 | 100 | 25 | 37 | 175 | 70 | 105 | 234 | 91 | 20 | 4 | 6.5 |
| 8-0573-30 | 30.0** | 254 | 116 | 150 | 35 | 45 | 241 | 84 | 157 | 317 | 127 | 20 | 4 | 17.2 |

* Design factor 5:1

**Design factor 4:1

| Item No. | Working Load Limit lbs* | Dimensions (inch) | | | | | | | | | | | N.W. | |
|-----------|----------------------------|-------------------|------|------|------|------|------|------|------|-------|------|------|------|------|
| | | A | B | C | D | E | F | G | H | L | W | HV | a | lbs |
| 8-0573-01 | 2200 | 3.27 | 1.61 | 1.89 | 0.55 | 0.55 | 3.39 | 1.06 | 2.28 | 4.29 | 1.97 | 0.20 | 0.12 | 1.1 |
| 8-0573-03 | 6600 | 3.86 | 1.89 | 2.28 | 0.67 | 0.67 | 3.35 | 1.22 | 2.13 | 4.49 | 2.28 | 0.24 | 0.12 | 2.0 |
| 8-0573-05 | 11000 | 4.72 | 2.48 | 2.60 | 0.87 | 0.87 | 4.65 | 1.61 | 3.03 | 6.18 | 2.52 | 0.28 | 0.12 | 2.9 |
| 8-0573-08 | 17600 | 4.76 | 2.87 | 2.68 | 1.02 | 1.02 | 4.80 | 2.09 | 2.72 | 6.65 | 2.36 | 0.39 | 0.16 | 5.3 |
| 8-0573-10 | 22000 | 5.75 | 2.87 | 3.23 | 0.79 | 1.18 | 5.55 | 2.09 | 3.46 | 7.52 | 2.95 | 0.39 | 0.16 | 6.2 |
| 8-0573-20 | 44000** | 7.32 | 3.66 | 3.94 | 0.98 | 1.46 | 6.89 | 2.76 | 4.13 | 9.21 | 3.58 | 0.79 | 0.16 | 14.3 |
| 8-0573-30 | 66000** | 10.00 | 4.57 | 5.91 | 1.38 | 1.77 | 9.49 | 3.31 | 6.18 | 12.48 | 5.00 | 0.79 | 0.16 | 37.8 |

* Design factor 5:1

**Design factor 4:1

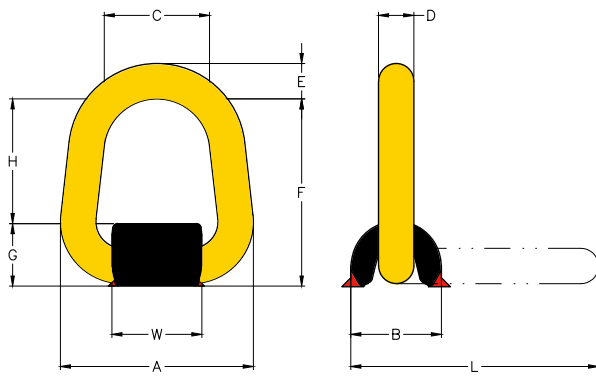

180° Pivot

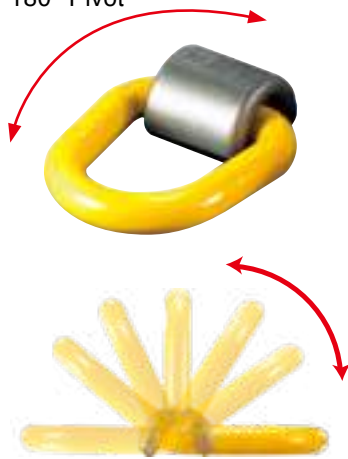

Stop at Any Angle

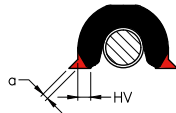

- Pivots through 180°.
- Manufactured from forged alloy steel, quenched and tempered.
- Manufactured and tested in accordance with EN1677-1.
- Load rated parts are 100% magnaflux crack detected.
- Individual forged parts are traceable to Test Certification.
- Proof tested to 2.5 times the WLL.
- All YOKE Lifting points meet or exceed all the requirements of ASME B30.26.
- WLL forged onto each product for quick and easy identification.
- Lugs designed to assist the welding process.
- A protected spring keeps the load ring in a required position. The parts are connected in such a way that they remain captive. The spring also reduces noise caused by vibrations.
- Never apply load except in the same direction with the pivot direction.

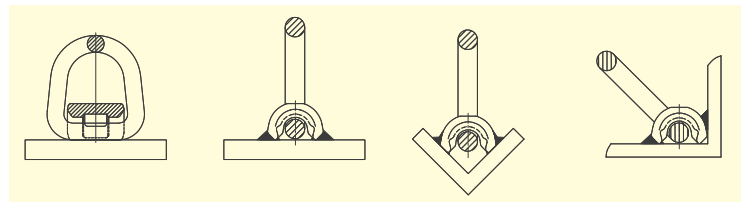

Weld-on Point

Designed with spring, stop at any angle
Metric (8-057)& Imperial (8-057)

| Item No. | Working Load Limit | Dimensions (mm) | | | | | | | | | | | | N.W. |
|-----------|--------------------|-----------------|----|----|----|----|-----|----|----|-----|----|----|----|------|
| | | tonnes | A | B | C | D | E | F | G | H | L | W | HV | |
| 8-057-1T | 1.0 | 83 | 41 | 48 | 14 | 14 | 86 | 27 | 58 | 109 | 50 | 5 | 3 | 0.5 |
| 8-057-3T | 3.0 | 98 | 48 | 58 | 17 | 17 | 85 | 31 | 54 | 114 | 58 | 6 | 3 | 0.9 |
| 8-057-5T | 5.0 | 120 | 63 | 66 | 22 | 22 | 118 | 41 | 77 | 157 | 64 | 7 | 3 | 1.3 |
| 8-057-8T | 8.0 | 121 | 73 | 68 | 26 | 26 | 122 | 53 | 69 | 169 | 60 | 10 | 4 | 2.6 |
| 8-057-10T | 10.0 | 146 | 73 | 82 | 20 | 30 | 141 | 53 | 88 | 191 | 75 | 10 | 4 | 2.8 |

* Design factor 5:1

| Item No. | Working Load Limit | Dimensions (inch) | | | | | | | | | | | | N.W. |
|-----------|--------------------|-------------------|------|------|------|------|------|------|------|------|------|------|------|------|
| | | lbs | A | B | C | D | E | F | G | H | L | W | HV | |
| 8-057-1T | 2200 | 3.27 | 1.61 | 1.89 | 0.55 | 0.55 | 3.39 | 1.06 | 2.28 | 4.29 | 1.97 | 0.20 | 0.12 | 1.1 |
| 8-057-3T | 6600 | 3.86 | 1.89 | 2.28 | 0.67 | 0.67 | 3.35 | 1.22 | 2.13 | 4.49 | 2.28 | 0.24 | 0.12 | 2.0 |
| 8-057-5T | 11000 | 4.72 | 2.48 | 2.60 | 0.87 | 0.87 | 4.65 | 1.61 | 3.03 | 6.18 | 2.52 | 0.28 | 0.12 | 2.9 |
| 8-057-8T | 17600 | 4.76 | 2.87 | 2.68 | 1.02 | 1.02 | 4.80 | 2.09 | 2.72 | 6.65 | 2.36 | 0.39 | 0.16 | 5.7 |
| 8-057-10T | 22000 | 5.75 | 2.87 | 3.23 | 0.79 | 1.18 | 5.55 | 2.09 | 3.46 | 7.52 | 2.95 | 0.39 | 0.16 | 6.2 |

* Design factor 5:1

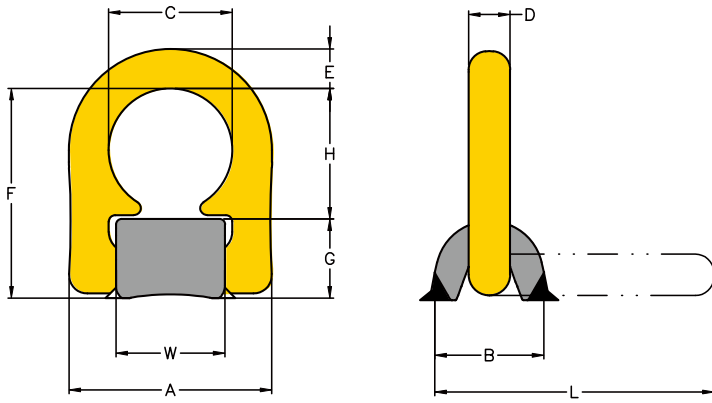

- Load ring pivots 180°.
- Full Loading Capacity in all directions.
- Manufactured from forged alloy steel, quenched and tempered.
- Tested in accordance with EN1677-1.
- 100% magnaflux crack detected.
- Parts individually forged with batch code to ensure full traceability.
- The permitted WLL forged onto each product for quick and easy identification.
- Lugs designed to assist the welding process.
- A protected spring keeps the loading ring in the required position. The parts are connected in such a way that they remain captive. The spring also reduces noise caused by vibrations.

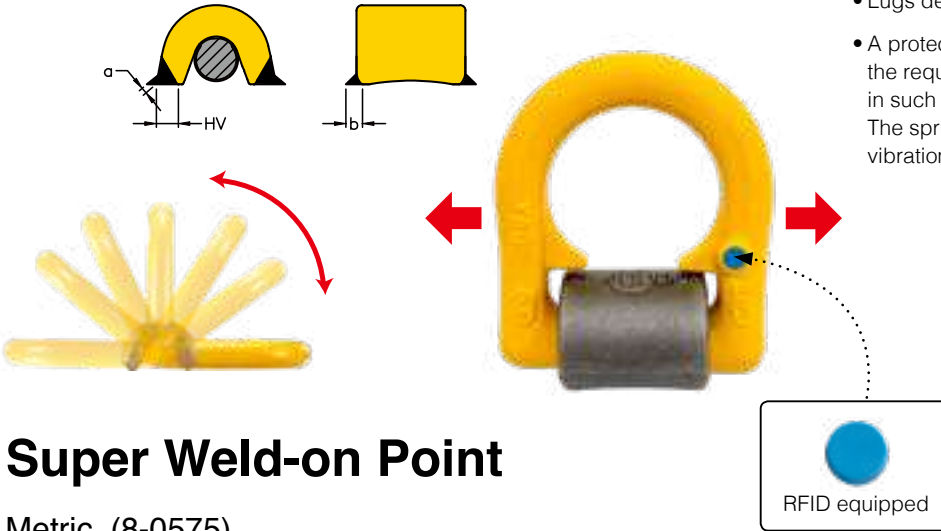

Super Weld-on Point

Metric (8-0575)

| Item No. | Working Load Limit tonnes* | Dimensions (mm) | | | | | | | | | | N.W. | | | |
|------------|-------------------------------|-----------------|----|-----|----|----|-----|----|-----|-----|----|------|---|---|------|
| | | A | B | C | D | E | F | G | H | L | W | HV | a | b | kg |
| 8-0575-015 | 1.5 | 64 | 31 | 38 | 13 | 13 | 63 | 24 | 39 | 84 | 32 | 5 | 3 | 3 | 0.32 |
| 8-0575-025 | 2.5 | 74 | 39 | 45 | 16 | 15 | 75 | 28 | 47 | 98 | 39 | 8 | 3 | 3 | 0.49 |
| 8-0575-040 | 4.0 | 84 | 40 | 51 | 16 | 17 | 81 | 29 | 52 | 108 | 45 | 9 | 3 | 3 | 0.67 |
| 8-0575-067 | 6.7 | 110 | 60 | 67 | 23 | 22 | 115 | 43 | 72 | 152 | 59 | 12 | 4 | 4 | 1.71 |
| 8-0575-100 | 10.0 | 122 | 72 | 67 | 27 | 22 | 124 | 51 | 73 | 165 | 59 | 17 | 5 | 7 | 2.45 |
| 8-0575-160 | 16.0 | 180 | 92 | 100 | 26 | 32 | 172 | 66 | 106 | 228 | 89 | 25 | 6 | 8 | 6.33 |

*Design factor 4:1

Super Weld-on Point

Imperial (8-0575)

| Item No. | Working Load Limit lbs* | Dimensions (inch) | | | | | | | | | | N.W. | | | |
|------------|----------------------------|-------------------|------|------|------|------|------|------|------|------|------|------|------|------|-------|
| | | A | B | C | D | E | F | G | H | L | W | HV | a | b | lbs |
| 8-0575-015 | 3300 | 2.52 | 1.22 | 1.50 | 0.51 | 0.51 | 2.48 | 0.95 | 1.54 | 3.31 | 1.26 | 0.20 | 0.12 | 0.12 | 0.70 |
| 8-0575-025 | 5500 | 2.91 | 1.54 | 1.77 | 0.63 | 0.59 | 2.95 | 1.10 | 1.85 | 3.86 | 1.54 | 0.32 | 0.12 | 0.12 | 1.08 |
| 8-0575-040 | 8800 | 3.31 | 1.58 | 2.01 | 0.63 | 0.67 | 3.19 | 1.14 | 2.05 | 4.25 | 1.77 | 0.35 | 0.12 | 0.12 | 1.47 |
| 8-0575-067 | 14750 | 4.33 | 2.36 | 2.64 | 0.91 | 0.87 | 4.53 | 1.69 | 2.84 | 5.99 | 2.32 | 0.47 | 0.16 | 0.16 | 3.76 |
| 8-0575-100 | 22000 | 4.80 | 2.84 | 2.64 | 1.06 | 0.87 | 4.88 | 2.01 | 2.87 | 6.50 | 2.32 | 0.67 | 0.20 | 0.28 | 5.39 |
| 8-0575-160 | 35200 | 7.09 | 3.62 | 3.94 | 1.02 | 1.26 | 6.77 | 2.60 | 4.17 | 8.98 | 3.50 | 0.98 | 0.24 | 0.32 | 13.93 |

*Design factor 4:1

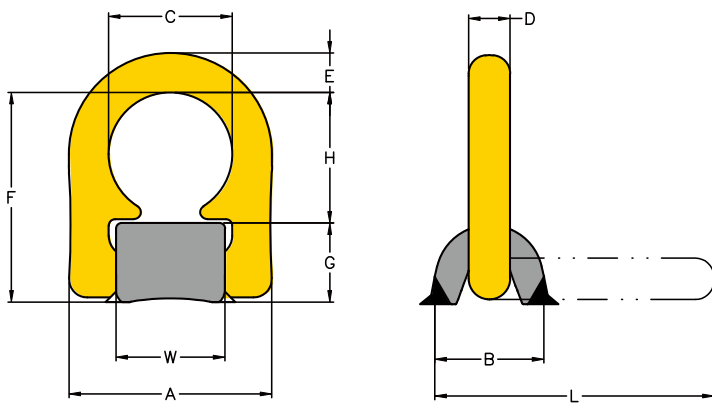

- Lashing ring pivots 180°
- Full Lashing Capacity in all directions.
- Manufactured from forged alloy steel, quenched and tempered.
- Tested in accordance with EN1677-1.
- 100% magnaflux crack detected.
- Parts individually forged with batch code to ensure full traceability.
- The permitted lashing capacity "LC" in daN forged onto each product for quick and easy identification.
- Lugs designed to assist the welding process.
- A protected spring keeps the lashing ring in the required position. The parts are connected in such a way that they remain captive. The spring also reduces noise caused by vibrations.

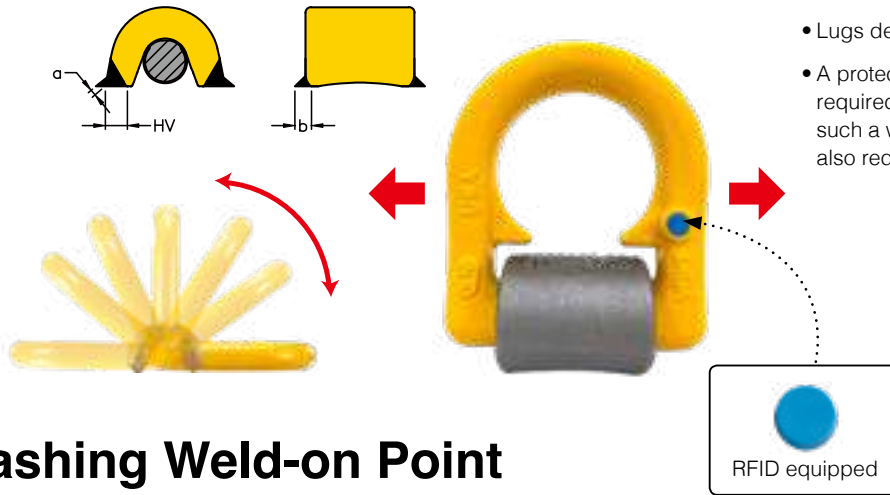

Lashing Weld-on Point

Metric (8-0576)

| Item No. | Lashing Capacity daN | Dimensions (mm) | | | | | | | | | | | N.W. | | |
|------------|-------------------------|-----------------|----|-----|----|----|-----|----|-----|-----|----|----|------|---|------|
| | | A | B | C | D | E | F | G | H | L | W | HV | a | b | kg |
| 8-0576-030 | 3000 | 64 | 31 | 38 | 13 | 13 | 63 | 24 | 39 | 84 | 32 | 5 | 3 | 3 | 0.32 |
| 8-0576-050 | 5000 | 74 | 39 | 45 | 16 | 15 | 75 | 28 | 47 | 98 | 39 | 8 | 3 | 3 | 0.49 |
| 8-0576-080 | 8000 | 84 | 40 | 51 | 16 | 17 | 81 | 29 | 52 | 108 | 45 | 9 | 3 | 3 | 0.67 |
| 8-0576-134 | 13400 | 110 | 60 | 67 | 23 | 22 | 115 | 43 | 72 | 152 | 59 | 12 | 4 | 4 | 1.71 |
| 8-0576-200 | 20000 | 122 | 72 | 67 | 27 | 22 | 124 | 51 | 73 | 165 | 59 | 17 | 5 | 7 | 2.45 |
| 8-0576-320 | 32000 | 180 | 92 | 100 | 26 | 32 | 172 | 66 | 106 | 228 | 89 | 25 | 6 | 8 | 6.33 |

*Design factor 2:1

Lashing Weld-on Point

Imperial (8-0576)

| Item No. | Lashing Capacity lbs | Dimensions (inch) | | | | | | | | | | | N.W. | | |
|------------|-------------------------|-------------------|------|------|------|------|------|------|------|------|------|------|------|------|-------|
| | | A | B | C | D | E | F | G | H | L | W | HV | a | b | lbs |
| 8-0576-030 | 6600 | 2.52 | 1.22 | 1.50 | 0.51 | 0.51 | 2.48 | 0.95 | 1.54 | 3.31 | 1.26 | 0.20 | 0.12 | 0.12 | 0.70 |
| 8-0576-050 | 11000 | 2.91 | 1.54 | 1.77 | 0.63 | 0.59 | 2.95 | 1.10 | 1.85 | 3.86 | 1.54 | 0.32 | 0.12 | 0.12 | 1.08 |
| 8-0576-080 | 17600 | 3.31 | 1.58 | 2.01 | 0.63 | 0.67 | 3.19 | 1.14 | 2.05 | 4.25 | 1.77 | 0.35 | 0.12 | 0.12 | 1.47 |
| 8-0576-134 | 29500 | 4.33 | 2.36 | 2.64 | 0.91 | 0.87 | 4.53 | 1.69 | 2.84 | 5.99 | 2.32 | 0.47 | 0.16 | 0.16 | 3.76 |
| 8-0576-200 | 44000 | 4.80 | 2.84 | 2.64 | 1.06 | 0.87 | 4.88 | 2.01 | 2.87 | 6.50 | 2.32 | 0.67 | 0.20 | 0.28 | 5.39 |
| 8-0576-320 | 70400 | 7.09 | 3.62 | 3.94 | 1.02 | 1.26 | 6.77 | 2.60 | 4.17 | 8.98 | 3.50 | 0.98 | 0.24 | 0.32 | 13.93 |

*Design factor 2:1

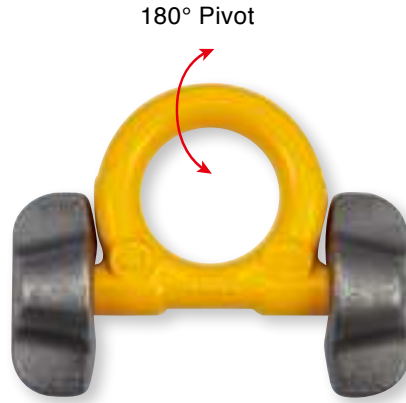
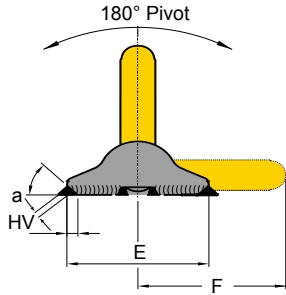
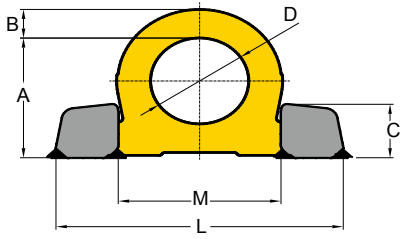

- Pivots 180°, designed minimizes head room.
- Manufactured from forged alloy steel, quenched and tempered.
- Manufactured and tested in accordance with EN1677-1.
- Certified by DGUV GS-OA-15-04.
- Load rated parts are 100% magnaflux crack detected.
- Individual forged parts are traceable to Test Certification.
- Proof tested to 2.5 times the WLL.
- The two points of attachment facilitate an even and optimal force distribution into the work piece and thus, usage of thinner base plates is possible.
- The welding block is forged out of material with excellent welding properties.
- Low profile design with high strength.
- The ring is stowable thus avoiding the hazards of tripping and snagging.



Weld-on Ring

Metric (8-082)

| Item No. | Working Load Limit tonnes | Dimensions (mm) | | | | | | | | | | N.W. kg |
|----------|------------------------------|-----------------|----|----|-----|-----|-----|-----|-----|----|---|------------|
| | | A | B | C | D | E | F | L | M | HV | a | |
| 8-082-04 | 4.0 | 66 | 14 | 30 | 48 | 65 | 70 | 135 | 76 | 5 | 3 | 0.6 |
| 8-082-06 | 6.7 | 85 | 20 | 39 | 60 | 89 | 91 | 171 | 98 | 5 | 3 | 1.5 |
| 8-082-10 | 10.0 | 95 | 21 | 46 | 65 | 100 | 100 | 196 | 106 | 7 | 4 | 2.4 |
| 8-082-16 | 16.0 | 127 | 30 | 57 | 90 | 130 | 136 | 263 | 149 | 8 | 4 | 5.5 |
| 8-082-30 | 31.5 | 178 | 42 | 75 | 130 | 160 | 195 | 375 | 213 | 15 | 4 | 15.8 |

* Design factor 4:1

Weld-on Ring

Imperial (8-082)

| Item No. | Working Load Limit tonnes | Dimensions (inch) | | | | | | | | | | N.W. lbs |
|----------|------------------------------|-------------------|------|------|------|------|------|-------|------|------|-----|-------------|
| | | A | B | C | D | E | F | L | M | HV | a | |
| 8-082-04 | 4.0 | 2.60 | 0.55 | 1.18 | 1.89 | 2.56 | 2.76 | 5.31 | 2.99 | 0.20 | 0.1 | 1.3 |
| 8-082-06 | 6.7 | 3.35 | 0.79 | 1.54 | 2.36 | 3.50 | 3.58 | 6.73 | 3.86 | 0.20 | 0.1 | 3.3 |
| 8-082-10 | 10.0 | 3.74 | 0.83 | 1.81 | 2.56 | 3.94 | 3.94 | 7.72 | 4.17 | 0.28 | 0.2 | 5.3 |
| 8-082-16 | 16.0 | 5.00 | 1.18 | 2.24 | 3.54 | 5.12 | 5.35 | 10.35 | 5.87 | 0.31 | 0.2 | 12.1 |
| 8-082-30 | 31.5 | 7.01 | 1.65 | 2.95 | 5.12 | 6.30 | 7.68 | 14.76 | 8.39 | 0.59 | 0.2 | 34.8 |

* Design factor 4:1

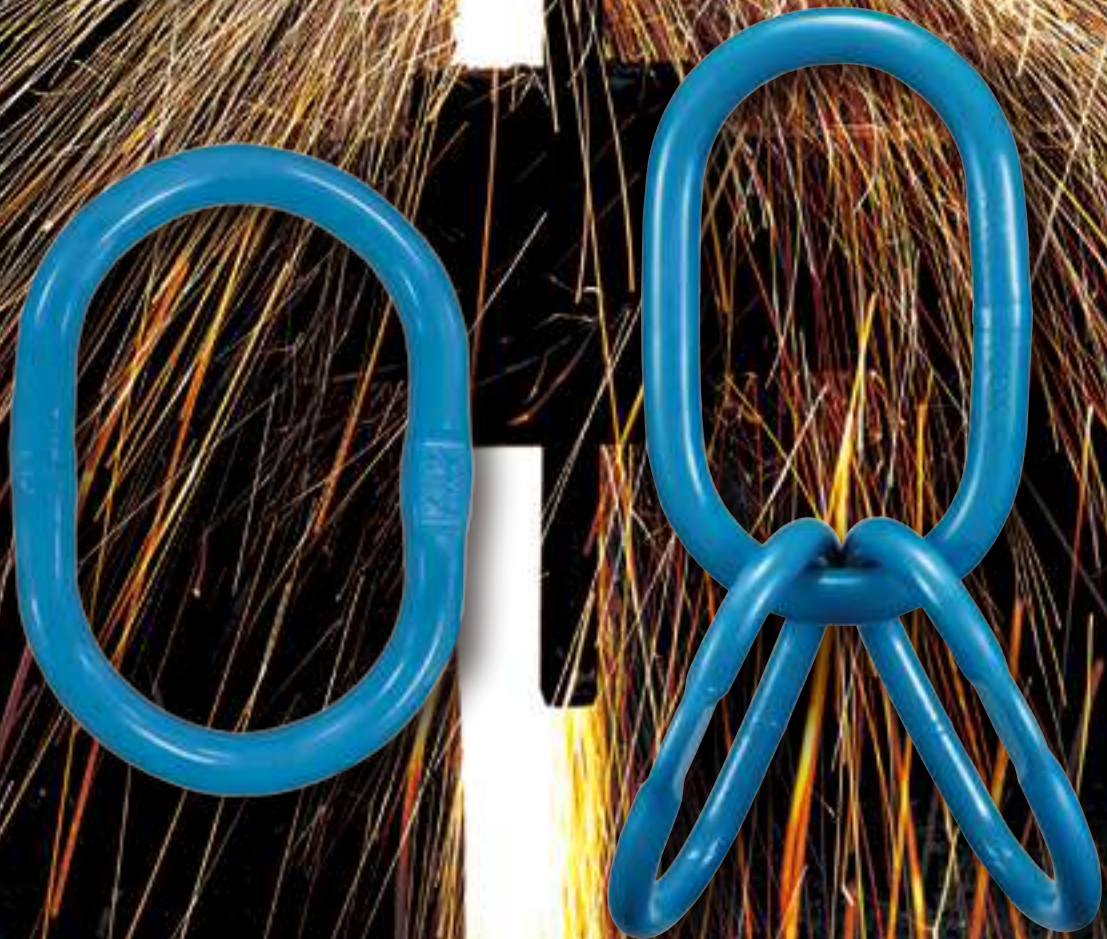

EX **TREME-100**

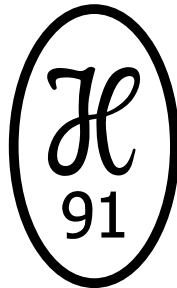





DANGER: Overhead lifting presents a very real danger of severe injury or loss of life if lifting equipment is not used properly. Please read and understand all of these instructions prior to using any lifting sling or sling assembly. Sling should only be used by qualified persons who are responsible for the sling selection, inspection and use.

Grade 100 Chain Sling Components

| WORKING LOAD LIMITS IN TONNES acc. to PAS 1061 | | | | | | |
|--|--------|-------------------------------------|-------------------------|-------------------------------------|-------------------------|------|
| | | | | | | |
| Load Factor | 1 | 1.4 | 1 | 2.1 | 1.5 | 1.6 |
| For Chain Size mm | tonnes | β 0 - 45° α 0 - 90° | 45° - 60° 90° - 120° | β 0 - 45° α 0 - 90° | 45° - 60° 90° - 120° | |
| 6 | 1.4 | 2.0 | 1.4 | 2.9 | 2.1 | 2.2 |
| 7 | 1.9 | 2.7 | 1.9 | 4.0 | 2.9 | 3.0 |
| 8 | 2.5 | 3.5 | 2.5 | 5.3 | 3.8 | 4.0 |
| 10 | 4.0 | 5.6 | 4.0 | 8.4 | 6.0 | 6.4 |
| 13 | 6.7 | 9.4 | 6.7 | 14.1 | 10.1 | 10.7 |
| 16 | 10.0 | 14.0 | 10.0 | 21.0 | 15.0 | 16.0 |
| 20 | 16.0 | 22.4 | 16.0 | 33.6 | 24.0 | 25.6 |
| 22 | 19.0 | 26.5 | 19.0 | 39.9 | 28.5 | 30.4 |
| 26 | 26.5 | 37.1 | 26.5 | 55.7 | 39.8 | 42.4 |
| 32 | 40.0 | 56.0 | 40.0 | 84.0 | 60.0 | 64.0 |

**Safety factor 4:1 above limits are valid for standard use and equally loaded slings. Properly use and maintenance of your YOKE chain slings will give long life and enable you to carry out your lifting operations efficiently and safely.

Warning: Never exceed a vertical sling angle of 60°

SAFE USE

- Never load in excess of the rated capacity for the application.
- Keep a record of all slings in use.
- User should remove all twists from a chain leg before lifting and, should never knot a chain.
- Always use YOKE shortening hook or clutch when chain slings should be shortened.
- Always inspect to insure that chain is free from damage or wear before use.
- Always inspect all sling components prior to each use.
- Ensure that chain is protected from any sharp corners on the load.
- Ensure that the master link articulates freely on the hook of the crane or other lifting appliance.
- Never tip load hooks. The load should always be supported correctly in the bowl of the hook.
- Always use the correct size sling for the load, allowing for the included angle and the possibility of unequal loading.
- Personnel must keep all body parts from between the sling and the load, and from between the sling and the crane/hoist hook. Persons shall never ride the chain sling/rope sling or web sling or the load during lifting or while suspended. Persons must stand clear of all loads while lifting or while suspended. During lifting, with or without the load, personnel must be alert for possible snagging of the load or the chain sling.

MAINTENANCE

- A thorough examination should be carried out by a competent person at intervals at least every year or more frequently according to statutory regulations, type of use and past records.
- Chains with bent links or with cracks or gouges in the link should be replaced , as should deformed components such as bent master links , deformed hooks and any fittings showing signs of damage.
- Chain and components wear should never exceed 10%of the original dimensions.
- Once a chain sling has been overloaded it must be taken out of service.
- Store chain slings on a properly designed rack. They should not be left lying on the floor where they may suffer mechanical or corrosion damage or may be lost.

LIMITATION ON USE

- YOKE alloy chain or chain slings should not be used in acid or caustic solutions nor in heavily acidic or caustic laden atmospheres. The high tensile strength of the heat treated alloy material in alloy steel chains and components is susceptible to hydrogen embrittlement when exposed to acids.
- YOKE slings must not be heat-treated, galvanized, plated, coated or subject to any process involving heating or pickling. Each of these processes can have dangerous effects and will invalidate the manufacturer certificate.
- YOKE slings may be used at temperatures between -40°C to 200°C with no reduction in the working load limit . The use of YOKE chain slings within the permissible temperature range in the table below does not require any permanent reduction in working load limit when the chain sling is returned to normal temperatures. A sling accidentally exposed to temperatures in excess of the maximum permissible should be withdrawn form service immediately and returned to the distributor for thorough examination.

- When using YOKE slings in exceptionally hazardous conditions, the degree of hazard should be assessed by a competent person and the Working Load Limit adjusted accordingly. Examples are lifting of potentially dangerous loads such as molten metals, corrosive materials or fissile material and including certain offshore activities.

| Sling temperature (F) | Sling temperature (C) | Reduction in Working Load Limit |
|-----------------------|-----------------------|---------------------------------|
| -40°F to 400°F | -40°C to 200°C | None |
| 400°F to 550°F | 200°C to 300°C | 10% |
| 550°F to 750°F | 300°C to 400°C | 25% |
| Above 750°F | Above 400°C | Do not use. |

Examples Of Chain Slings

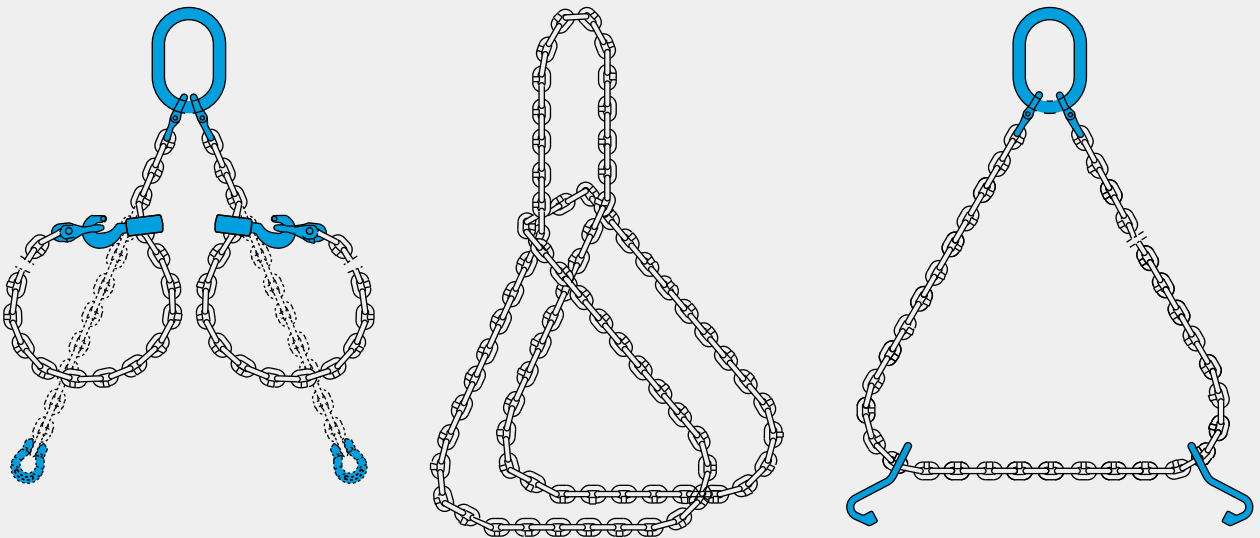
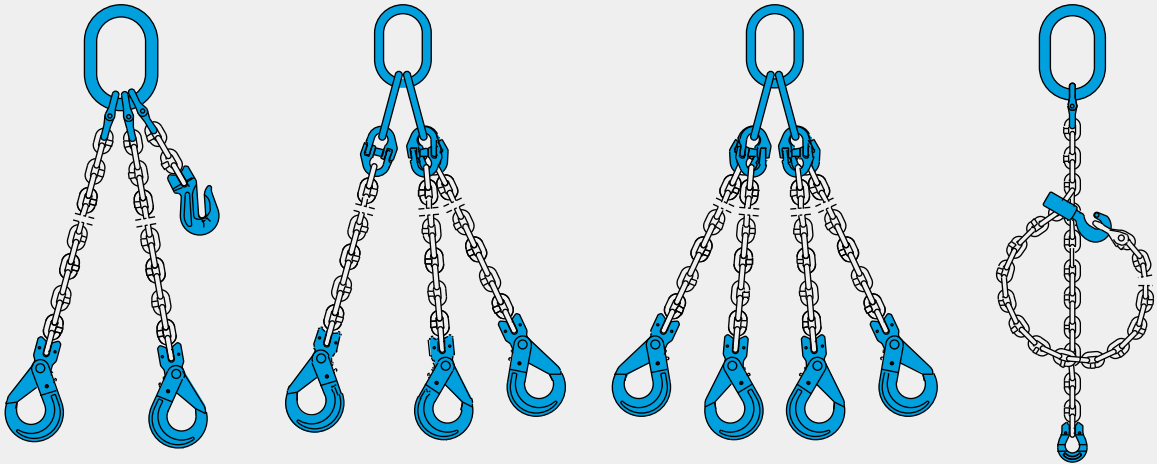
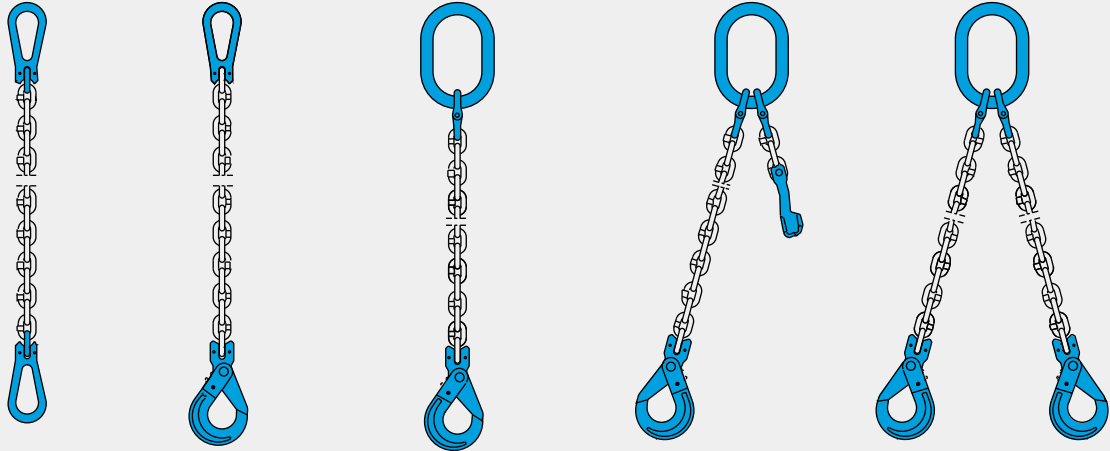

Examples Of Wire Rope Sling & Web Sling

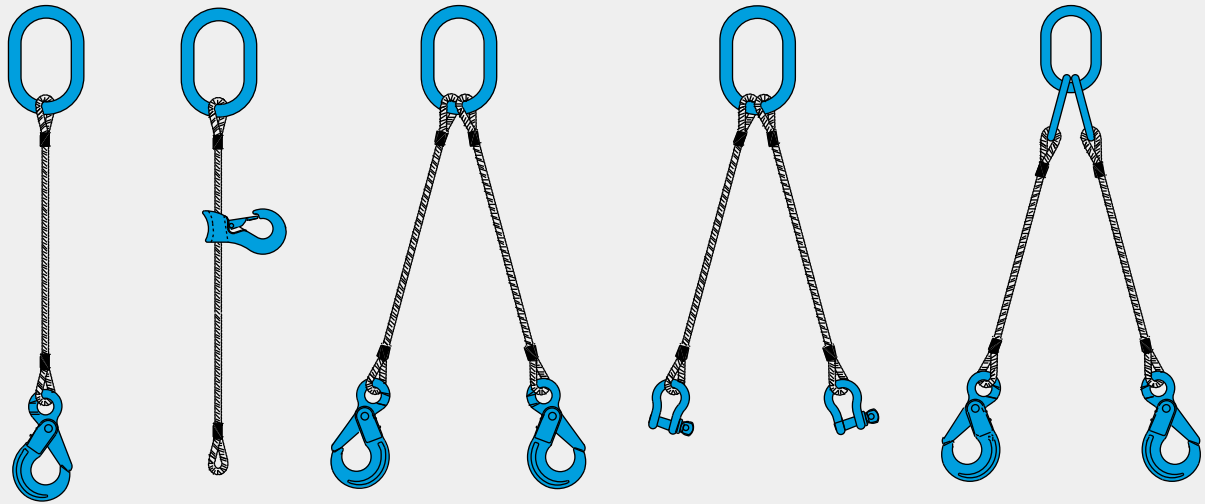

Incorrect Use

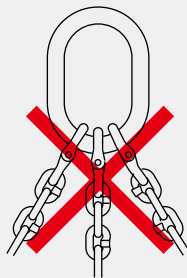
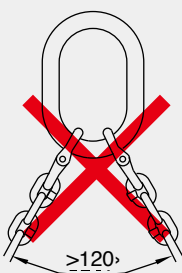
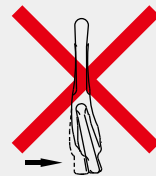
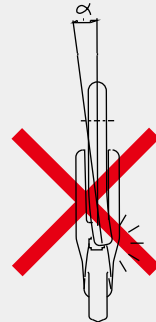
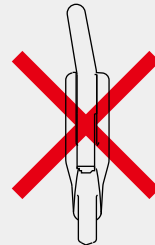
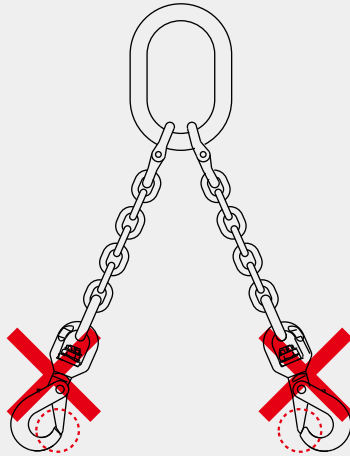
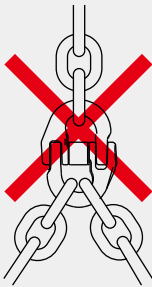
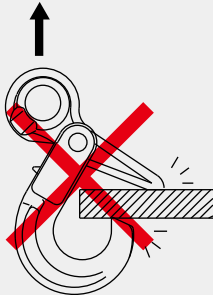
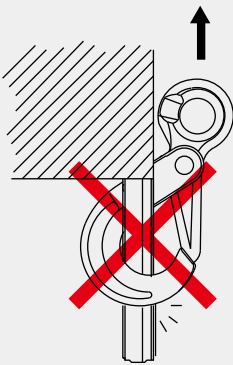
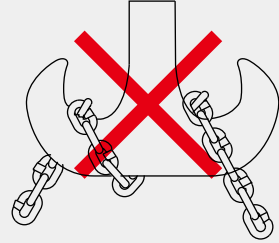
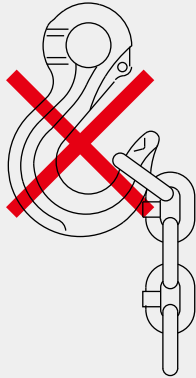

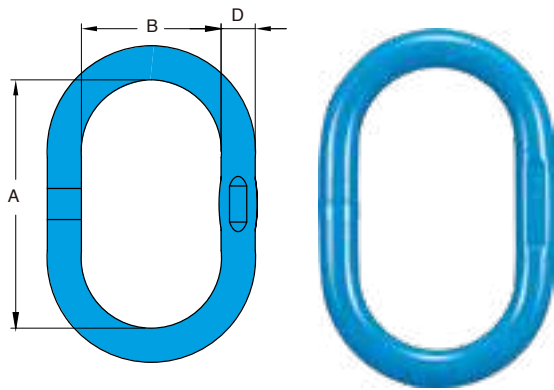

- Quenched and Tempered Alloy Steel.
- At least 25% greater WLL than traditional G80 products.
- Manufactured in accordance with ASTM A952/A952M, ASME B30.9, ASME B30.26, EN 1677-4 and OSHA 1910.184.
- Certified by DGUV GS-OA-15-05.
- Proof Load tested at 2.5 times the WLL with certification for each batch manufactured.
- Design Factor 5:1.
- Fatigue rated to 20,000 cycles at 1.5 times the WLL.
- Tempering temperature at a minimum of 400°C.
- Welded Master Link designed for 1-2 legs Chain, Wire Rope and Webbing Slings.
- Each link is marked with batch number that links to the test certificate with full traceability to raw materials.



X-001 Welded Master Link

| Item No. | Code No. | For Grade 100 Chain (mm) | | WLL β 0-45° tonnes | Proof Load kN | Used to single hook according to DIN 15401 No. | Dimensions (mm) | | | N.W. kg |
|-----------|----------|--------------------------|-------|--------------------------|------------------|--|-----------------|-----|-----|------------|
| | | 1-leg | 2-leg | | | | D | A | B | |
| X-001-13 | AD-13 | 6,7,8 | 6 | 2.8 | 69 | 2.5 | 13 | 120 | 60 | 0.4 |
| X-001-16 | AD-16 | 10 | 7,8 | 4.0 | 98 | 6.0 | 16 | 160 | 90 | 0.7 |
| X-001-19 | AD-19 | 13 | 10 | 6.7 | 164 | 6.0 | 19 | 160 | 90 | 1.1 |
| X-001-22 | AD-22 | 13 | 10 | 8.9 | 208 | 8.0 | 22 | 180 | 100 | 1.6 |
| X-001-25 | AD-25 | 16 | 13 | 11.5 | 282 | 10.0 | 25 | 210 | 115 | 2.4 |
| X-001-251 | AD-251 | 16 | 13 | 11.5 | 282 | 16.0 | 25 | 275 | 145 | 3.1 |
| X-001-28 | AD-28 | 16 | 13 | 13.0 | 319 | 16.0 | 28 | 275 | 145 | 3.9 |
| X-001-281 | AD-281 | 16 | 13 | 13.0 | 319 | 8.0 | 28 | 190 | 100 | 2.8 |
| X-001-32 | AD-32 | 20 | 16 | 17.1 | 417 | 16.0 | 32 | 275 | 145 | 5.1 |
| X-001-36 | AD-36 | 22 | 20 | 24.0 | 588 | 20.0 | 36 | 285 | 155 | 6.9 |
| X-001-40 | AD-40 | 26 | 22 | 28.1 | 688 | 20.0 | 40 | 300 | 160 | 8.9 |
| X-001-45 | AD-45 | 26 | 26 | 38.3 | 938 | 25.0 | 45 | 340 | 180 | 12.8 |
| X-001-50 | AD-50 | 32 | 26 | 45.0 | 1103 | 32.0 | 50 | 350 | 195 | 16.6 |

Sub-links SPEC for X-007. Items in grey area are not for sale individually.

| | | | | | | | | | | |
|-----------|--------|----|-----|------|------|---|----|-----|-----|------|
| X-001-161 | AD-161 | 10 | 7,8 | 4.0 | 98 | - | 16 | 140 | 70 | 0.6 |
| X-001-361 | AD-361 | 22 | 20 | 24.0 | 588 | - | 36 | 275 | 145 | 6.6 |
| X-001-401 | AD-401 | 26 | 22 | 28.1 | 688 | - | 40 | 260 | 130 | 7.8 |
| X-001-601 | AD-601 | 32 | 32 | 65.0 | 1593 | - | 60 | 410 | 220 | 27.9 |
| X-001-701 | AD-701 | - | - | 85.0 | 2083 | - | 70 | 400 | 200 | 37.7 |

★ Design factor 5:1 proof tested and certified.

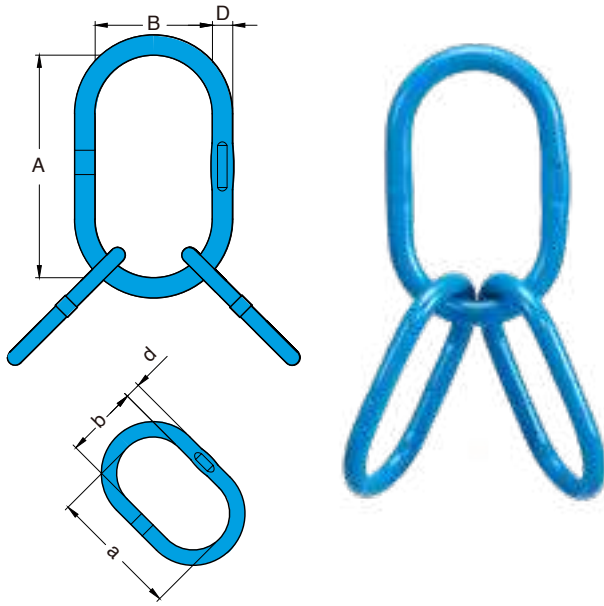

- Quenched and Tempered Alloy Steel.
- At least 25% greater WLL than traditional G80 products.
- Manufactured in accordance with ASTM A952/A952M, ASME B30.9, ASME B30.26, EN 1677-4 and OSHA 1910.184.
- Certified by DGVV GS-OA-15-05.
- Proof Load tested at 2.5 times the WLL with certification for each batch manufactured.
- Design Factor 5:1.
- Fatigue rated to 20,000 cycles at 1.5 times the WLL.
- Tempering temperature at a minimum of 400°C.
- Welded Master Link designed for 3-4 legs Chain, Wire Rope and Webbing Slings.
- Each link is marked with batch number that links to the test certificate with full traceability to raw materials.



X-007 Welded Master Link Assembly

| Item No. | Assembled with | For Grade 100 Chain (mm) | | WLL β 0-45° tonnes | Proof Load kN | Used to single hook according to DIN 15401 No. | Dimensions (mm) | | | | | | N.W. kg |
|----------|-----------------|--------------------------|--|--------------------------|------------------|--|-----------------|-----|-----|----|-----|-----|------------|
| | | 3 and 4-leg | | | | | D | A | B | d | a | b | |
| X-007-19 | AD-19 +2 AD-161 | 7,8 | | 5.3 | 130 | 6 | 19 | 160 | 90 | 16 | 140 | 70 | 2.4 |
| X-007-25 | AD-251+2 AD-19 | 10 | | 8.9 | 218 | 16 | 25 | 275 | 145 | 19 | 160 | 90 | 5.2 |
| X-007-28 | AD-28 +2 AD-22 | 10 | | 12.9 | 316 | 16 | 28 | 275 | 145 | 22 | 180 | 100 | 7.1 |
| X-007-32 | AD-32 +2 AD-25 | 13 | | 17.0 | 417 | 16 | 32 | 275 | 145 | 25 | 210 | 115 | 10.0 |
| X-007-36 | AD-361+2 AD-281 | 16 | | 23.6 | 578 | 16 | 36 | 275 | 145 | 28 | 190 | 100 | 12.2 |
| X-007-40 | AD-40 +2 AD-32 | 16 | | 28.1 | 688 | 20 | 40 | 300 | 160 | 32 | 275 | 145 | 19.2 |
| X-007-45 | AD-45 +2 AD-36 | 20 | | 38.3 | 938 | 25 | 45 | 340 | 180 | 36 | 285 | 155 | 26.5 |
| X-007-50 | AD-50 +2 AD-401 | 22 | | 45.0 | 1103 | 32 | 50 | 350 | 195 | 40 | 260 | 130 | 33.9 |

★ Design factor 5:1 proof tested and certified.

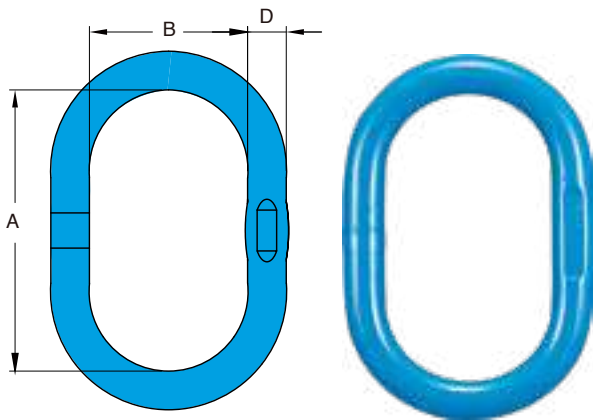

- Quenched and Tempered Alloy Steel.
- At least 25% greater WLL than traditional G80 products.
- Manufactured in accordance with ASTM A952/A952M, ASME B30.9, ASME B30.26, EN 1677-4 and OSHA 1910.184.
- Proof Load tested at 2.5 times the WLL with certification for each batch manufactured.
- Design Factor 4:1.
- Fatigue rated to 20,000 cycles at 1.5 times the WLL.
- Tempering temperature at a minimum of 400°C.
- Welded Master Link designed for 1-2 legs Chain, Wire Rope and Webbing Slings.
- Each link is marked with batch number that links to the test certificate with full traceability to raw materials.

X-002 Welded Master Link

| Item No. | Code No. | For Grade 100 Chain (mm) | | WLL β 0-45° tonnes | Proof Load kN | Used to single hook according to DIN 15401 No. | Dimensions (mm) | | | N.W. kg |
|----------|----------|--------------------------|-------|--------------------------------|------------------|---|-----------------|-----|-----|------------|
| | | 1-leg | 2-leg | | | | D | A | B | |
| X-002-13 | BD-13 | 7,8 | 6 | 2.8 | 69 | 2.5 | 13 | 110 | 60 | 0.3 |
| X-002-16 | BD-16 | 10 | 7,8 | 4.0 | 98 | 2.5 | 16 | 110 | 60 | 0.5 |
| X-002-19 | BD-19 | 13 | 10 | 6.7 | 164 | 5.0 | 19 | 135 | 75 | 0.9 |
| X-002-22 | BD-22 | 13 | 10 | 8.5 | 208 | 6.0 | 22 | 160 | 90 | 1.5 |
| X-002-28 | BD-28 | 16 | 13 | 11.5 | 282 | 8.0 | 28 | 180 | 100 | 2.7 |
| X-002-32 | BD-32 | 20 | 16 | 17.0 | 417 | 10.0 | 32 | 200 | 110 | 3.9 |
| X-002-36 | BD-36 | 22 | 20 | 25.1 | 615 | 16.0 | 36 | 260 | 140 | 6.3 |
| X-002-45 | BD-45 | 26 | 22 | 38.3 | 938 | 25.0 | 45 | 300 | 180 | 11.8 |
| X-002-50 | BD-50 | 32 | 26 | 45.0 | 1103 | 32.0 | 50 | 300 | 200 | 15.2 |

★ Design factor 4:1 proof tested and certified.

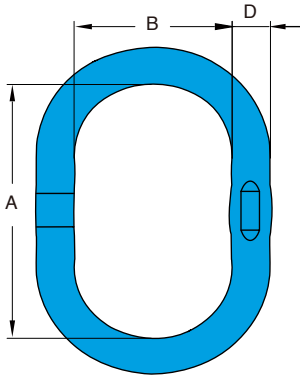

- Quenched and Tempered Alloy Steel.
- At least 25% greater WLL than traditional G80 products.
- Manufactured in accordance with ASTM A952/A952M, ASME B30.9, ASME B30.26, EN 1677-4 and OSHA 1910.184.
- Proof Load tested at 2.5 times the WLL with certification for each batch manufactured.
- Design Factor 4:1.
- Fatigue rated to 20,000 cycles at 1.5 times the WLL.
- Tempering temperature at a minimum of 400°C.
- Welded Master Link designed for 1-2 legs Chain, Wire Rope and Webbing Slings.
- Each link is marked with batch number that links to the test certificate with full traceability to raw materials.

X-002W Welded Master Link

| Item No. | Code No. | For Grade 100 Chain (mm) | | WLL β 0-45° tonnes | Proof Load kN | Used to single hook according to DIN 15401 No. | Dimensions (mm) | | | N.W. kg |
|-----------|----------|--------------------------|-------|--------------------------|---------------|--|-----------------|-----|-----|---------|
| | | 1-leg | 2-leg | | | | D | A | B | |
| X-002W-13 | CD-13 | 7,8 | 6 | 2.8 | 69 | 4 | 13 | 120 | 70 | 0.4 |
| X-002W-16 | CD-16 | 10 | 7,8 | 4.0 | 98 | 5 | 16 | 140 | 80 | 0.7 |
| X-002W-19 | CD-19 | 13 | 10 | 6.7 | 164 | 6 | 19 | 160 | 95 | 1.1 |
| X-002W-22 | CD-22 | 13 | 10 | 8.5 | 208 | 10 | 22 | 170 | 105 | 1.6 |
| X-002W-28 | CD-28 | 16 | 13 | 11.5 | 282 | 10 | 28 | 190 | 110 | 2.9 |
| X-002W-32 | CD-32 | 20 | 16 | 17.0 | 417 | 12 | 32 | 230 | 130 | 4.5 |
| X-002W-36 | CD-36 | 22 | 20 | 25.1 | 615 | 20 | 36 | 275 | 150 | 6.7 |

★ Design factor 4:1 proof tested and certified.

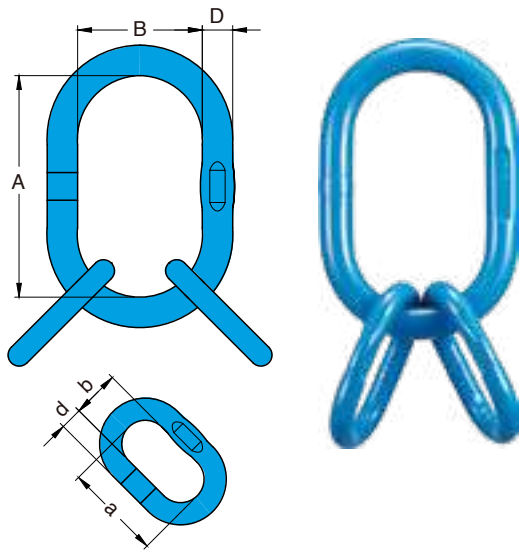

- Quenched and Tempered Alloy Steel.
- At least 25% greater WLL than traditional G80 products.
- Manufactured in accordance with ASTM A952/A952M, ASME B30.9, ASME B30.26, EN 1677-4 and OSHA 1910.184.
- Proof Load tested at 2.5 times the WLL with certification for each batch manufactured.
- Design Factor 4:1.
- Fatigue rated to 20,000 cycles at 1.5 times the WLL.
- Tempering temperature at a minimum of 400°C.
- Welded Master Link designed for 3-4 legs Chain, Wire Rope and Webbing Slings.
- Each link is marked with batch number that links to the test certificate with full traceability to raw materials.

X-006 Welded Master Link Assembly

| Item No. | Assembled with | For | | Proof Load | Used to single hook according to DIN 15401 No. | Dimensions (mm) | | | | | | N.W. |
|-----------|----------------|----------------------|--------------------|------------|--|-----------------|-----|-----|----|-----|----|------|
| | | Grade 100 Chain (mm) | WLL β 0-45° tonnes | | | 3 and 4-leg | D | A | B | d | a | |
| X-006-19 | BD-19 +2 DD-13 | 6 | 4.2 | 103 | 5 | 19 | 135 | 75 | 13 | 54 | 25 | 1.3 |
| X-006-22 | BD-22 +2 DD-16 | 7,8 | 8.2 | 201 | 6 | 22 | 160 | 90 | 16 | 70 | 34 | 2.2 |
| X-006-28 | BD-28 +2 DD-19 | 10 | 10.7 | 262 | 8 | 28 | 180 | 100 | 19 | 85 | 40 | 3.9 |
| X-006-32 | BD-32 +2 DD-22 | 13 | 15.7 | 385 | 10 | 32 | 200 | 110 | 22 | 115 | 50 | 6.1 |
| X-006-36 | BD-36 +2 DD-28 | 16 | 22.2 | 544 | 16 | 36 | 260 | 140 | 28 | 140 | 65 | 10.6 |
| X-006-50 | BD-50 +2 DD-32 | 20 | 34.1 | 835 | 32 | 50 | 300 | 200 | 32 | 150 | 70 | 21.2 |
| X-006-501 | BD-50 +2 DD-36 | 22 | 40.0 | 980 | 32 | 50 | 300 | 200 | 36 | 170 | 75 | 23.8 |

★ Design factor 4:1 proof tested and certified.

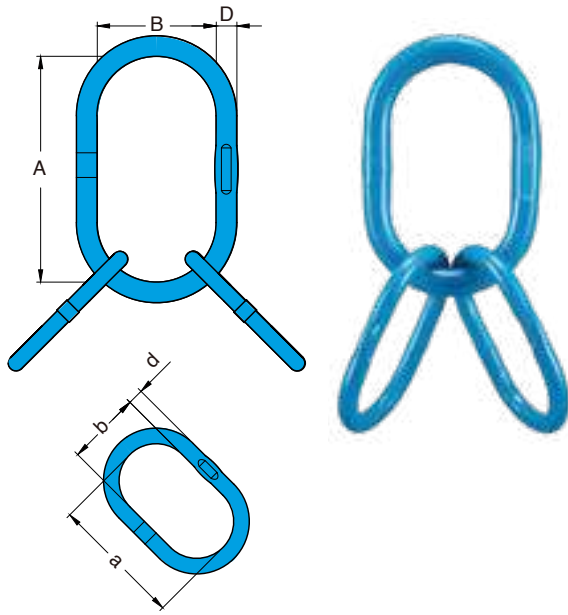

- Quenched and Tempered Alloy Steel.
- At least 25% greater WLL than traditional G80 products.
- Manufactured in accordance with ASTM A952/A952M, ASME B30.9, ASME B30.26, EN 1677-4 and OSHA 1910.184.
- Proof Load tested at 2.5 times the WLL with certification for each batch manufactured.
- Design Factor 4:1.
- Fatigue rated to 20,000 cycles at 1.5 times the WLL.
- Tempering temperature at a minimum of 400°C.
- Welded Master Link designed for 3-4 legs Chain, Wire Rope and Webbing Slings.
- Each link is marked with batch number that links to the test certificate with full traceability to raw materials.

X-006L Welded Master Link Assembly

| Item No. | Assembled with | For | WLL | Proof | Used to single | Dimensions (mm) | | | | | | N.W. | |
|-----------|----------------|-------------|-----|-------|----------------|-----------------|------------|--------|------|----------------|-----|------|------|
| | | Grade 100 | | | | β 0-45° | Chain (mm) | tonnes | Load | hook according | D | | A |
| X-006L-19 | BD-19 +2 BD-13 | 3 and 4-leg | 6 | 4.2 | 103 | 5 | 19 | 135 | 75 | 13 | 110 | 60 | 1.6 |
| X-006L-22 | BD-22 +2 BD-16 | | 7,8 | 8.2 | 201 | 6 | 22 | 160 | 90 | 16 | 110 | 60 | 2.5 |
| X-006L-32 | BD-32 +2 BD-22 | | 10 | 10.7 | 262 | 10 | 32 | 200 | 110 | 22 | 160 | 90 | 6.9 |
| X-006L-36 | BD-36 +2 BD-28 | | 13 | 15.7 | 385 | 16 | 36 | 260 | 140 | 28 | 180 | 100 | 11.8 |
| X-006L-45 | BD-45 +2 BD-32 | | 16 | 22.2 | 544 | 25 | 45 | 300 | 180 | 32 | 200 | 110 | 19.7 |

★ Design factor 4:1 proof tested and certified.

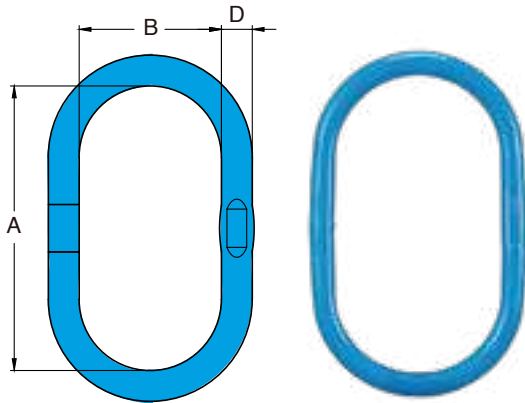

- Quenched and Tempered Alloy Steel.
- At least 25% greater WLL than traditional G80 products.
- Manufactured in accordance with ASTM A952/A952M, ASME B30.9, ASME B30.26, EN 1677-4 and OSHA 1910.184.
- Proof Load tested at 2.5 times the WLL with certification for each batch manufactured.
- Design Factor 4:1.
- Fatigue rated to 20,000 cycles at 1.5 times the WLL.
- Tempering temperature at a minimum of 400°C.
- Welded Master Link designed for 1 leg Chain, Wire Rope and Webbing Slings.
- Each link is marked with batch number that links to the test certificate with full traceability to raw materials.

X-0080 Welded Master Link

| Item No. | Code No. | For | WLL | Proof | Used to single hook | Dimensions (mm) | | | N.W. |
|------------------|----------|------------|--------|-------|---------------------|-----------------|------|------------------|------|
| | | Grade 100 | | | | β 0-45° | Load | according to DIN | |
| | | Chain (mm) | tonnes | kN | 15401 No. | | | | kg |
| | | 1-leg | | | | | | | |
| X-0080-28 | ED-28 | 13 | 6.7 | 164 | 25 | 28 | 340 | 180 | 4.7 |
| X-0080-32 | ED-32 | 16 | 10.0 | 245 | 25 | 32 | 340 | 180 | 6.2 |
| X-0080-40 | ED-40 | 20,22 | 19.0 | 466 | 25 | 40 | 340 | 180 | 10.0 |

★ Design factor 4:1 proof tested and certified.

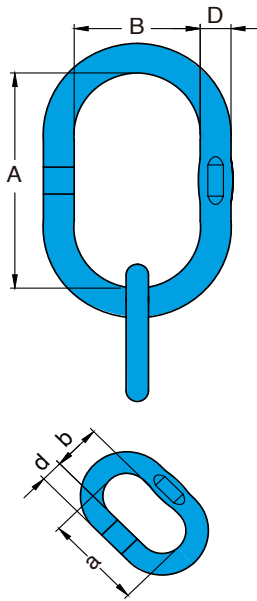

- Quenched and Tempered Alloy Steel.
- At least 25% greater WLL than traditional G80 products.
- Manufactured in accordance with ASTM A952/A952M, ASME B30.9, ASME B30.26, EN 1677-4 and OSHA 1910.184.
- Proof Load tested at 2.5 times the WLL with certification for each batch manufactured.
- Design Factor 4:1.
- Fatigue rated to 20,000 cycles at 1.5 times the WLL.
- Tempering temperature at a minimum of 400°C.
- Welded Master Link designed for 1 leg Chain, Wire Rope and Webbing Slings.
- Each link is marked with batch number that links to the test certificate with full traceability to raw materials.

X-0081 Welded Master Link Assembly

| Item No. | Assembled with | For | WLL | Proof | Used to single | Dimensions (mm) | | | | | | N.W. |
|-----------|----------------|----------------|--------|-------|----------------|-----------------|-------------------|-----|----|----|----|------|
| | | Grade 100 | | | | β 0-45° | hook according to | D | A | B | d | |
| | | Chain (mm) | tonnes | Load | DIN 15401 No. | | | | | | | kg |
| X-0081-22 | ED-22 +1 DD-13 | 1-leg 6,7,8 | 2.5 | 61 | 25 | 22 | 340 | 180 | 13 | 54 | 25 | 3.2 |
| X-0081-28 | ED-28 +1 DD-16 | 10 | 4.0 | 98 | 25 | 28 | 340 | 180 | 16 | 70 | 34 | 5.4 |

★ Design factor 4:1 proof tested and certified.

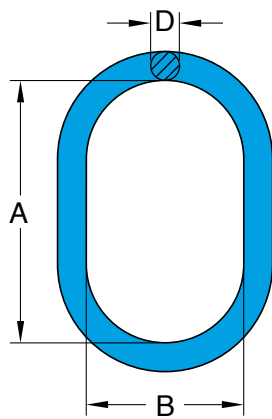

- Quenched and Tempered Alloy Steel.
- At least 25% greater WLL than traditional G80 products.
- Manufactured in accordance with ASTM A952/A952M, ASME B30.9, ASME B30.26, EN 1677-4 and OSHA 1910.184.
- Proof Load tested at 2.5 times the WLL with certification for each batch manufactured.
- Design Factor 4:1.
- Fatigue rated to 20,000 cycles at 1.5 times the WLL.
- Tempering temperature at a minimum of 400°C.
- Designed for 1-2 legs Chain, Wire Rope and Webbing Slings.
- Each link is marked with batch number that links to the test certificate with full traceability to raw materials.

Forged

G-100 Forged Oblong Master Link

| Item No. | For Grade 100 Chain (mm) | | WLL β 0-45° tonnes | Proof Load kN | Used to single hook according to DIN 15401 No. | Dimensions (mm) | | | N.W. kg |
|------------|--------------------------|--------|--------------------------|------------------|--|-----------------|-----|-----|------------|
| | 1-leg | 2-leg | | | | D | A | B | |
| X-003-06 | 6 | - | 1.4 | 34 | 2.5 | 11 | 100 | 60 | 0.2 |
| X-003-0806 | 7,8 | 6 | 2.9 | 71 | 4.0 | 14 | 120 | 70 | 0.5 |
| X-003-1008 | 10 | 7, 8 | 5.3 | 130 | 5.0 | 17 | 140 | 80 | 0.7 |
| X-003-13 | 13 | - | 6.7 | 164 | 6.0 | 19 | 150 | 90 | 1.1 |
| X-003-1310 | 13 | 10 | 8.4 | 206 | 6.0 | 22 | 160 | 95 | 1.5 |
| X-003-16 | 16 | - | 10.0 | 245 | 10.0 | 25 | 190 | 110 | 2.3 |
| X-003-1613 | 16 | 13 | 14.1 | 345 | 8.0 | 28 | 180 | 105 | 2.7 |
| X-003-19 | 19,20 | - | 16.0 | 392 | 10.0 | 30 | 200 | 120 | 3.5 |
| X-003-2216 | 22 | 16 | 21.0 | 515 | 16.0 | 34 | 240 | 140 | 5.3 |
| X-003-26 | 26 | - | 26.5 | 649 | 16.0 | 38 | 250 | 150 | 7.4 |
| X-003-2619 | 26 | 19, 20 | 33.6 | 823 | 16.0 | 40 | 250 | 150 | 8.3 |
| X-003-3222 | 32 | 22 | 39.9 | 978 | 25.0 | 45 | 300 | 180 | 12.3 |

★ Design factor 4:1 proof tested and certified.

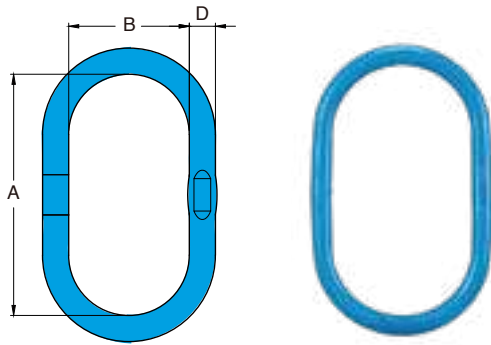

- Quenched and Tempered Alloy Steel.
- At least 25% greater WLL than traditional G80 products.
- Manufactured in accordance with ASTM A952/A952M, ASME B30.9, ASME B30.26 ,EN 1677-4, and OSHA 1910.184.
- Proof Load tested at 2.5 times the WLL with certification for each batch manufactured.
- Design Factor 4:1.
- Fatigue rated to 20,000 cycles at 1.5 times the WLL.
- Tempering temperature at a minimum of 400°C.
- Welded Master Link designed for 1-2 legs Chain, Wire Rope and Webbing Slings.
- Each link is marked with batch number that links to the test certificate with full traceability to raw materials.

X-004 Welded Master Link

Sub-links SPEC for X-0081, X-0082, X-006W. Items in grey area are not for sale individually.

| Item No. | Code No. | For Grade 100 Chain (mm) | | WLL β 0-45° tonnes | Proof Load kN | Dimensions (mm) | | | N.W. kg |
|----------|----------|--------------------------|-------|--------------------------------|------------------|-----------------|-----|-----|------------|
| | | 1-leg | 2-leg | | | D | A | B | |
| X-004-13 | DD-13 | 10 | 6 | 4.0 | 98 | 13 | 54 | 25 | 0.2 |
| X-004-16 | DD-16 | 13 | 7,8 | 6.7 | 164 | 16 | 70 | 34 | 0.4 |
| X-004-19 | DD-19 | 16 | 10 | 10.0 | 245 | 19 | 85 | 40 | 0.6 |
| X-004-22 | DD-22 | 20 | 13 | 14.0 | 343 | 22 | 115 | 50 | 1.1 |
| X-004-28 | DD-28 | 22 | 16 | 19.0 | 466 | 28 | 140 | 65 | 2.1 |
| X-004-32 | DD-32 | 26 | 20 | 26.5 | 649 | 32 | 150 | 70 | 3.0 |
| X-004-36 | DD-36 | - | 22 | 31.0 | 760 | 36 | 170 | 75 | 4.3 |
| X-004-40 | DD-40 | 32 | - | 40.4 | 990 | 40 | 170 | 80 | 5.5 |
| X-004-45 | DD-45 | - | 26 | 42.4 | 1039 | 45 | 170 | 80 | 7.1 |
| X-004-50 | DD-50 | - | 32 | 64.0 | 1568 | 50 | 200 | 100 | 10.3 |

★ Design factor 4:1 proof tested and certified.

Grab Chain Sling

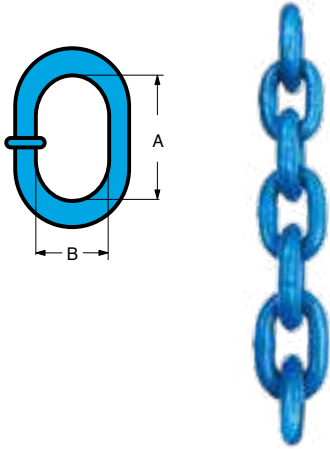

- Quenched and Tempered Alloy Steel.
- At least 25% greater WLL than traditional G80 chain
- Manufactured in accordance with EN 818-2
- Proof Load tested at 2.5 times the WLL
- Design Factor 4:1
- Temperature application range -20° up to 200°C
- Marked with grade (10) and batch number that links to the test certificate with full traceability to raw material.
- Blue painted surface finish.

Grade 100 Lifting Chain

| Item No. | Chain Dia mm | Working Load Limit tonnes* | Dimensions (mm) | | Length Per Carton meters | N.W. kg Per m |
|----------|-----------------|----------------------------------|-----------------|---------|--------------------------------|---------------------|
| | | | A mm | B mm | | |
| X-009-06 | 6 | 1.4 | 18 | 8.5 | 1,200 | 0.6 |
| X-009-08 | 8 | 2.5 | 24 | 10.4 | 800 | 1.1 |
| X-009-10 | 10 | 4.0 | 30 | 13.0 | 500 | 2.2 |
| X-009-13 | 13 | 6.7 | 39 | 16.9 | 300 | 3.7 |
| X-009-16 | 16 | 10.0 | 48 | 20.8 | 200 | 6.0 |

★ Design factor 4:1 proof tested and certified.
Tested Acc. to EN 818

Grab Chain Sling

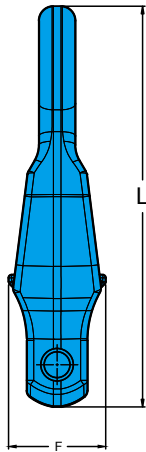
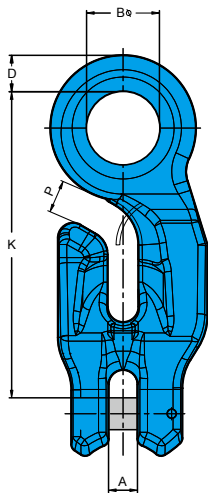

- Quenched and Tempered Alloy Steel.
- At least 25% greater WLL than traditional G80 products.
- Manufactured in accordance with DIN EN 1677-1 and DIN 5692.
- Proof Load tested at 2.5 times the WLL with certification for each batch manufactured.
- Design Factor 4:1
- Fatigue rated to 20,000 cycles at 1.5 times the WLL.
- Tempering temperature at a minimum of 400°C.
- Each hook is marked with batch number that links to the test certificate with full traceability to raw materials.

G-100 Eye Grab Hook

| Item No. | WLL tonnes | For Grade 100 Chain | | Dimensions (mm) | | | | | | N.W. kg | |
|----------|---------------|---------------------------|--|-----------------|----|----|----|-----|-----|------------|------|
| | | mm | | A | B | D | F | K | L | | P |
| X-079-06 | 1.4 | 5, 6 | | 8 | 18 | 9 | 24 | 76 | 99 | 12 | 0.24 |
| X-079-07 | 2.5 | 7, 8 | | 10 | 24 | 13 | 32 | 102 | 134 | 12 | 0.54 |
| X-079-10 | 4 | 10 | | 12 | 31 | 14 | 40 | 125 | 163 | 15 | 1.03 |
| X-079-13 | 6.7 | 13 | | 16 | 37 | 18 | 51 | 158 | 208 | 20 | 2.18 |
| X-079-16 | 10 | 16 | | 19 | 48 | 24 | 64 | 202 | 264 | 21 | 4.39 |

★ Design factor 4:1 proof tested and certified.

Grab Chain Sling

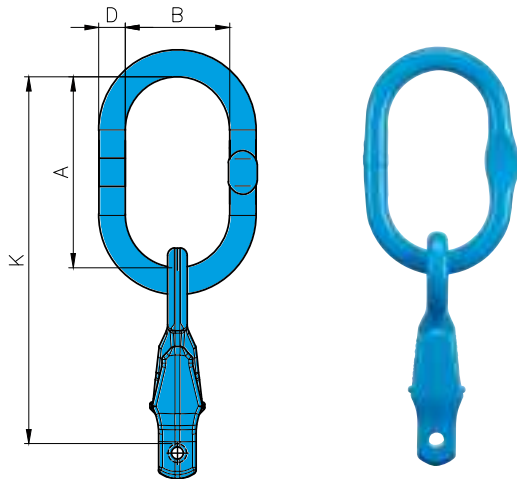

- Quenched and Tempered Alloy Steel.
- At least 25% greater WLL than traditional G80 products.
- Manufactured in accordance with EN 1677 and ASTM A952/ A 952M.
- Proof Load tested at 2.5 times the WLL with certification for each batch manufactured.
- Design Factor 4:1.
- Fatigue rated to 20,000 cycles at 1.5 times the WLL.
- Tempering temperature at a minimum of 400°C.
- Each link is marked with batch number that links to the test certificate with full traceability to raw materials.
- Fully integrated shortening clutch and master link.
- No reduction in WLL when shortening chain.
- Speedy assembly.
- Light weight system.
- Cost effective compared to slings which use multiple components.



G100 Single Leg Assembly

| Item No. | WLL tonnes | For Grade 100 Chain mm | Can be used on single hook Acc. To DIN15401 No. | Dimensions (mm) | | | | N.W. kg |
|----------|---------------|---------------------------------|--|-----------------|-----|-----|-----|------------|
| | | | | D | A | B | K | |
| X-A04-06 | 1.4 | 6 | 4 | 13 | 120 | 70 | 196 | 0.7 |
| X-A04-08 | 2.5 | 7,8 | 5 | 16 | 140 | 80 | 242 | 1.2 |
| X-A04-10 | 4.0 | 10 | 6 | 19 | 160 | 95 | 285 | 2.1 |
| X-A04-13 | 6.7 | 13 | 10 | 22 | 170 | 105 | 328 | 3.9 |
| X-A04-16 | 10.0 | 16 | 10 | 28 | 190 | 110 | 392 | 7.0 |

★ Design factor 4:1 proof tested and certified.

Grab Chain Sling

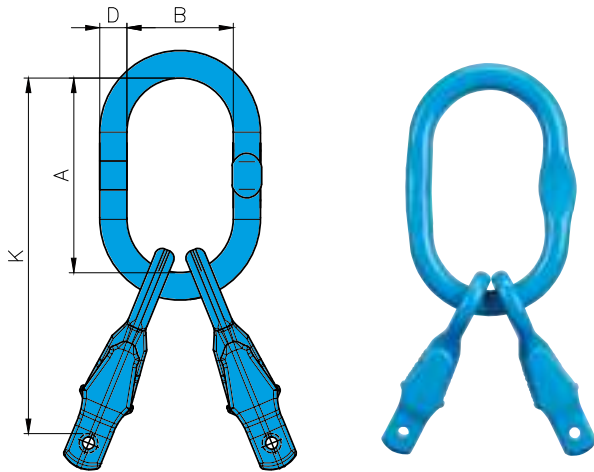

- Quenched and Tempered Alloy Steel.
- At least 25% greater WLL than traditional G80 products.
- Manufactured in accordance with EN 1677 and ASTM A952/ A 952M.
- Proof Load tested at 2.5 times the WLL with certification for each batch manufactured.
- Design Factor 4:1.
- Fatigue rated to 20,000 cycles at 1.5 times the WLL.
- Tempering temperature at a minimum of 400°C.
- Each link is marked with batch number that links to the test certificate with full traceability to raw materials.
- Fully integrated shortening clutch and master link.
- No reduction in WLL when shortening chain.
- Speedy assembly.
- Light weight system.
- Cost effective compared to slings which use multiple components.



G100 2 Leg Assembly

| Item No. | WLL | For Grade 100 Chain | Can be used on single hook Acc. To DIN15401 No. | Dimensions (mm) | | | | N.W. |
|----------|--------|---------------------|---|-----------------|-----|-----|-----|------|
| | tonnes | | | mm | D | A | B | K |
| X-A05-06 | 2.0 | 6 | 4 | 13 | 120 | 70 | 196 | 0.9 |
| X-A05-08 | 3.5 | 7,8 | 6 | 19 | 160 | 95 | 262 | 2.2 |
| X-A05-10 | 5.6 | 10 | 10 | 22 | 170 | 105 | 295 | 3.8 |
| X-A05-13 | 9.4 | 13 | 10 | 28 | 190 | 110 | 348 | 7.0 |
| X-A05-16 | 14.0 | 16 | 12 | 32 | 230 | 130 | 432 | 13.6 |

★ Design factor 4:1 proof tested and certified.

Grab Chain Sling

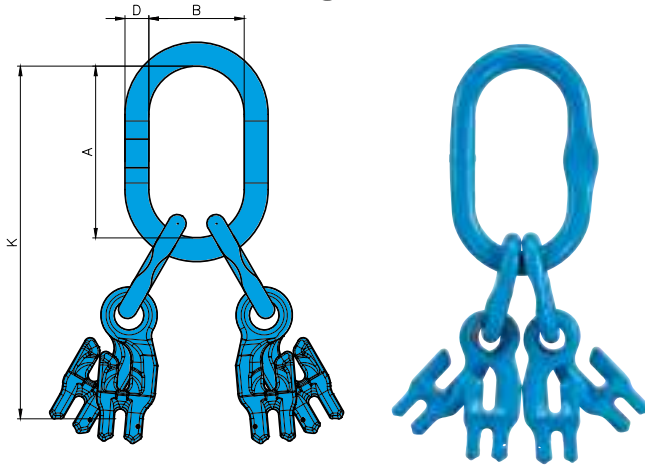

- Quenched and Tempered Alloy Steel.
- At least 25% greater WLL than traditional G80 products.
- Manufactured in accordance with EN 1677 and ASTM A952/ A 952M.
- Proof Load tested at 2.5 times the WLL with certification for each batch manufactured.
- Design Factor 4:1.
- Fatigue rated to 20,000 cycles at 1.5 times the WLL.
- Tempering temperature at a minimum of 400°C.
- Each link is marked with batch number that links to the test certificate with full traceability to raw materials.
- Fully integrated shortening clutch and master link.
- No reduction in WLL when shortening chain.
- Speedy assembly.
- Light weight system.
- Cost effective compared to slings which use multiple components

G100 4 Leg Assembly

| Item No. | WLL tonnes | For Grade 100 Chain mm | Can be used on single hook Acc. To DIN15401 No. | Dimensions (mm) | | | | N.W. kg |
|----------|---------------|---------------------------------|--|-----------------|-----|-----|-----|------------|
| | | | | D | A | B | K | |
| X-A06-06 | 2.9 | 6 | 6 | 19 | 160 | 95 | 290 | 2.4 |
| X-A06-08 | 5.3 | 7,8 | 10 | 22 | 170 | 105 | 342 | 4.6 |
| X-A06-10 | 8.4 | 10 | 10 | 28 | 190 | 110 | 400 | 8.1 |
| X-A06-13 | 14.1 | 13 | 12 | 32 | 230 | 130 | 503 | 15.8 |
| X-A06-16 | 21.0 | 16 | 20 | 36 | 275 | 150 | 617 | 28.9 |

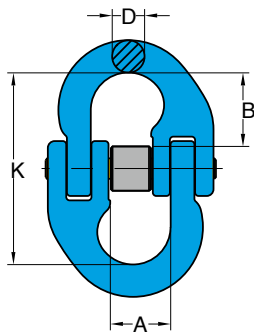

- Quenched and Tempered Alloy Steel.
- At least 25% greater WLL than traditional G80 products.
- Manufactured in accordance with EN 1677- 1 and ASTM A952/ A952M.
- Certified by DGUV GS-OA-15-05
- Proof Load tested at 2.5 times the WLL with certification for each batch manufactured.
- Design Factor 4:1.
- Fatigue rated to 20,000 cycles at 1.5 times the WLL.
- Suitable for use with both Grade 80 and Grade 100 chain.



Repair kit available for maintenance.

G-100 Connecting Link

| Item No. | For Grade 100 Chain | WLL tonnes* | Dimensions (mm) | | | | N.W. kg |
|----------|---------------------|----------------|-----------------|----|----|-----|------------|
| | mm | | A | B | D | K | |
| X-015-06 | 6 | 1.4 | 15 | 17 | 7 | 45 | 0.08 |
| X-015-07 | 7, 8 | 2.5 | 18 | 23 | 9 | 59 | 0.20 |
| X-015-10 | 10 | 4.0 | 25 | 27 | 11 | 69 | 0.30 |
| X-015-13 | 13 | 6.7 | 30 | 37 | 16 | 92 | 0.70 |
| X-015-16 | 16 | 10.0 | 36 | 39 | 19 | 101 | 1.20 |
| X-015-20 | 20 | 16.0 | 42 | 46 | 23 | 122 | 2.10 |
| X-015-22 | 22 | 19.0 | 49 | 59 | 24 | 152 | 3.50 |
| X-015-26 | 26 | 26.5 | 55 | 62 | 30 | 162 | 4.80 |
| X-015-32 | 32 | 40.0 | 69 | 79 | 36 | 203 | 9.00 |

★ Design factor 4:1 proof tested and certified.

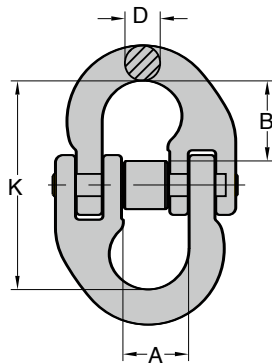

- Quenched and Tempered Alloy Steel.
- At least 25% greater WLL than traditional G80 products.
- Manufactured in accordance with EN 1677- 1 and ASTM A952/ A952M.
- Proof Load tested at 2.5 times the WLL with certification for each batch manufactured.
- Design Factor 4:1.
- Fatigue rated to 20,000 cycles at 1.5 times the WLL.
- Suitable for use with both Grade 80 and Grade 100 chain.
- Dacromet surface finish for enhanced corrosion resistance.



Special pin and sleeve designed for maintenance purpose.

G-100 Connecting Link

Dacromet® surface finish**

| Item No. | For Grade 100 Chain | WLL tonnes* | Dimensions (mm) | | | | N.W. kg |
|-----------|---------------------------|----------------|-----------------|----|----|-----|------------|
| | mm | | A | B | D | K | |
| X-M015-06 | 6 | 1.4 | 15 | 18 | 7 | 45 | 0.1 |
| X-M015-07 | 7, 8 | 2.5 | 18 | 25 | 9 | 59 | 0.2 |
| X-M015-10 | 10 | 4.0 | 25 | 28 | 11 | 69 | 0.3 |
| X-M015-13 | 13 | 6.7 | 30 | 38 | 16 | 92 | 0.7 |
| X-M015-16 | 16 | 10.0 | 36 | 41 | 19 | 101 | 1.2 |
| X-M015-20 | 20 | 16.0 | 42 | 49 | 23 | 122 | 2.1 |
| X-M015-22 | 22 | 19.0 | 49 | 63 | 24 | 152 | 3.5 |
| X-M015-26 | 26 | 26.5 | 55 | 66 | 30 | 162 | 4.8 |
| X-M015-32 | 32 | 40.0 | 69 | 87 | 36 | 203 | 9.0 |

★ Design factor 4:1 proof tested and certified.

YOKE®

Safety is our first priority™

New!
Safety Triggers



Quality Management System:



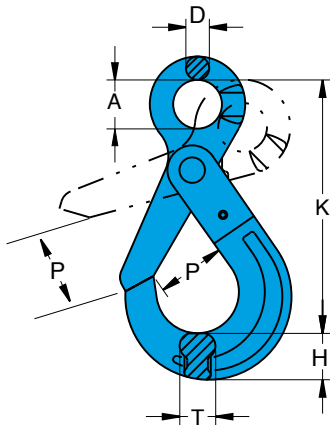

- Quenched and Tempered Alloy Steel.
- At least 25% greater WLL than traditional G80 products.
- Manufactured in accordance with EN 1677- 3 and ASME B30.26, ASME B30.10.
- Certified by DGVV GS-OA-15-05.
- Proof Load tested at 2.5 times the WLL with certification for each batch manufactured.
- Design Factor 4:1.
- Fatigue rated to 20,000 cycles at 1.5 times the WLL.
- Tempering temperature minimum 400°C
- Magnaflux crack detection is performed 100% on each batch.



8-P025

For most sizes



8-P025T

For 26mm

G-100 Eye Self Locking Hook

| Item No. | For Grade 100 Chain | WLL tonnes* | Dimensions (mm) | | | | | | N.W. kg |
|----------|---------------------------|----------------|-----------------|----|----|-----|----|----|------------|
| | mm | | A | D | H | K | P | T | |
| X-025-06 | 6 | 1.4 | 21 | 10 | 19 | 110 | 28 | 15 | 0.5 |
| X-025-07 | 7,8 | 2.5 | 25 | 11 | 24 | 136 | 34 | 20 | 0.8 |
| X-025-10 | 10 | 4.0 | 32 | 13 | 30 | 167 | 44 | 26 | 1.5 |
| X-025-13 | 13 | 6.7 | 40 | 16 | 39 | 207 | 51 | 30 | 3.0 |
| X-025-16 | 16 | 10.0 | 50 | 21 | 49 | 252 | 60 | 36 | 5.8 |
| X-025-20 | 20 | 16.0 | 60 | 23 | 65 | 293 | 70 | 53 | 10.0 |
| X-025-22 | 22 | 19.0 | 70 | 24 | 63 | 319 | 80 | 49 | 12.5 |
| X-025-26 | 26 | 26.5 | 80 | 25 | 69 | 343 | 99 | 56 | 15.0 |

★ Design factor 4:1 proof tested and certified.

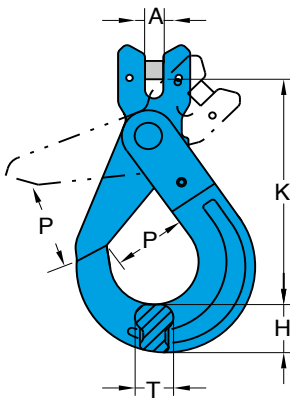

- Quenched and Tempered Alloy Steel.
- At least 25% greater WLL than traditional G80 products.
- Manufactured in accordance with EN 1677- 3 and ASME B30.26, ASME B30.10, PAS1061.
- Certified by DGUV GS-OA-15-05
- Proof Load tested at 2.5 times the WLL with certification for each batch manufactured.
- Design Factor 4:1.
- Fatigue rated to 20,000 cycles at 1.5 times the WLL.
- Tempering temperature minimum 400°C
- Magnaflux crack detection is performed 100% on each batch.



X-P026

For load pin replacement



8-P025T

For trigger replacement

G-100 Clevis Self Locking Hook

| Item No. | For Grade 100 Chain | WLL tonnes* | Dimensions (mm) | | | | | N.W. kg |
|----------|---------------------|----------------|-----------------|----|-----|----|----|------------|
| | mm | | A | H | K | P | T | |
| X-026-06 | 6 | 1.4 | 7 | 19 | 94 | 28 | 15 | 0.4 |
| X-026-07 | 7,8 | 2.5 | 9 | 24 | 119 | 34 | 20 | 0.9 |
| X-026-10 | 10 | 4.0 | 11 | 30 | 142 | 44 | 26 | 1.4 |
| X-026-13 | 13 | 6.7 | 15 | 39 | 178 | 52 | 30 | 3.0 |
| X-026-16 | 16 | 10.0 | 18 | 49 | 213 | 60 | 36 | 5.0 |
| X-026-20 | 20 | 16.0 | 25 | 65 | 251 | 70 | 53 | 11.0 |
| X-026-22 | 22 | 19.0 | 24 | 63 | 273 | 80 | 49 | 13.5 |

★ Design factor 4:1 proof tested and certified.

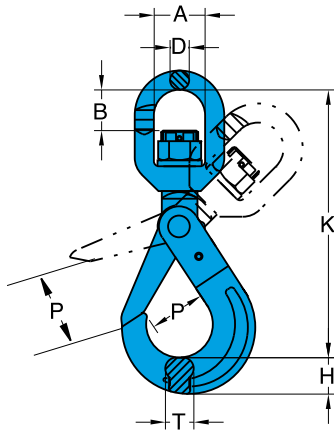

- Quenched and Tempered Alloy Steel.
- At least 25% greater WLL than traditional G80 products.
- Manufactured in accordance with EN 1677- 3 and ASME B30.26, ASME B30.10, PAS1061.
- Certified by DGUV GS-OA-15-05.
- Proof Load tested at 2.5 times the WLL with certification for each batch manufactured.
- Design Factor 4:1.
- Fatigue rated to 20,000 cycles at 1.5 times the WLL.
- Tempering temperature minimum 400°C
- Magnaflux crack detection is performed 100% on each batch.



8-P025T

For trigger

G-100 Swivel Self Locking Hook

With Brass Bushing

| Item No. | For Grade 100 Chain | WLL tonnes* | Dimensions (mm) | | | | | | | N.W. kg |
|----------|---------------------------|----------------|-----------------|-----|----|----|-----|----|----|------------|
| | mm | | A | B | D | H | K | P | T | |
| X-027-06 | 6 | 1.4 | 32 | 25 | 12 | 19 | 149 | 28 | 15 | 0.7 |
| X-027-07 | 7,8 | 2.5 | 36 | 30 | 13 | 24 | 186 | 34 | 20 | 1.2 |
| X-027-10 | 10 | 4.0 | 41 | 38 | 16 | 30 | 218 | 44 | 26 | 2.0 |
| X-027-13 | 13 | 6.7 | 46 | 48 | 21 | 39 | 276 | 51 | 30 | 4.1 |
| X-027-16 | 16 | 10.0 | 61 | 56 | 23 | 49 | 329 | 60 | 36 | 7.2 |
| X-027-20 | 20 | 16.0 | 74 | 86 | 25 | 65 | 403 | 70 | 53 | 13.0 |
| X-027-22 | 22 | 19.0 | 97 | 98 | 33 | 63 | 454 | 80 | 49 | 20.0 |
| X-027-26 | 26 | 26.5 | 123 | 120 | 51 | 69 | 535 | 99 | 56 | 33.0 |

★ Design factor 4:1 proof tested and certified.

⚠ WARNING INFORMATION : This hook is a positioning device and is not intended to rotate under load. For swivel hooks designed to rotate under load, see X-027N.

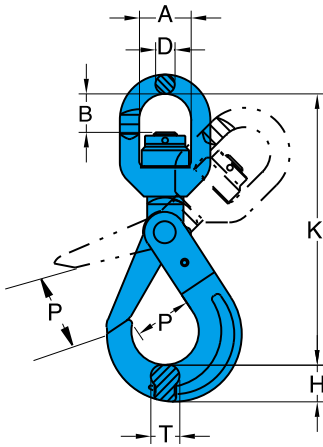

- Quenched and Tempered Alloy Steel.
- At least 25% greater WLL than traditional G80 products.
- Manufactured in accordance with EN 1677- 3 and ASME B30.26, ASME B30.10, PAS1061.
- Certified by DGUV GS-OA-15-05
- Proof Load tested at 2.5 times the WLL with certification for each batch manufactured.
- Design Factor 4:1.
- Fatigue rated to 20,000 cycles at 1.5 times the WLL.
- Tempering temperature minimum 400°C
- Magnaflux crack detection is performed 100% on each batch.
- Built with ball bearing and enables full swivel feature under load.



8-P025T
For trigger

G-100 Swivel Self Locking Hook

with Ball Bearing, which performs full swivel under load.

| Item No. | For Grade 100 Chain | WLL tonnes* | Dimensions (mm) | | | | | | | N.W. kg |
|-----------|---------------------------|----------------|-----------------|-----|----|----|-----|----|----|------------|
| | mm | | A | B | D | H | K | P | T | |
| X-027N-06 | 6 | 1.4 | 32 | 23 | 12 | 19 | 149 | 28 | 15 | 0.7 |
| X-027N-07 | 7,8 | 2.5 | 36 | 29 | 13 | 24 | 186 | 34 | 20 | 1.2 |
| X-027N-10 | 10 | 4.0 | 41 | 35 | 16 | 30 | 218 | 44 | 26 | 2.0 |
| X-027N-13 | 13 | 6.7 | 46 | 44 | 21 | 39 | 276 | 51 | 30 | 4.1 |
| X-027N-16 | 16 | 10.0 | 61 | 50 | 23 | 49 | 329 | 60 | 36 | 7.2 |
| X-027N-20 | 20 | 16.0 | 74 | 82 | 25 | 65 | 403 | 70 | 53 | 13.0 |
| X-027N-22 | 22 | 19.0 | 97 | 96 | 33 | 63 | 454 | 80 | 49 | 20.0 |
| X-027N-26 | 26 | 26.5 | 123 | 116 | 51 | 69 | 535 | 99 | 56 | 33.0 |

★ Design factor 4:1 proof tested and certified.

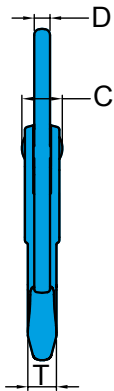
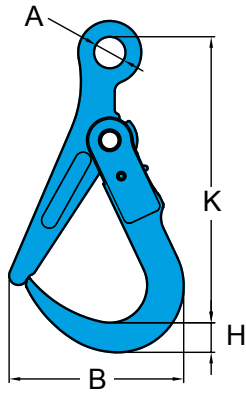

- Quenched and Tempered Alloy Steel.
- Proof Load tested at 2.5 times the WLL with certification for each batch manufactured.
- Design Factor 5:1.
- Fatigue rated to 20,000 cycles at 1.5 times the WLL.
- Tempering temperature minimum 400°C
- Magnaflux crack detection is performed 100% on each batch.

G-100 Super Lock Hook

| Item No. | WLL tonnes* | Dimensions (mm) | | | | | | | | N.W. kg |
|----------|----------------|-----------------|-----|----|----|----|-----|-----|----|------------|
| | | A | B | C | D | H | K | P | T | |
| X-019-02 | 2.0 | 32 | 177 | 41 | 16 | 30 | 290 | 108 | 29 | 3.5 |
| X-019-03 | 3.0 | 32 | 177 | 41 | 16 | 30 | 290 | 108 | 29 | 3.5 |

★ Design factor 5:1 proof tested and certified.

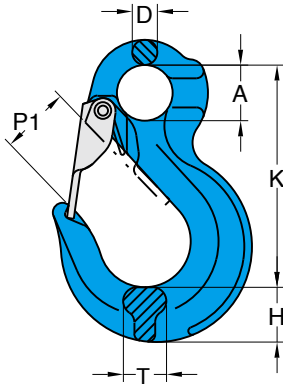

- Quenched and Tempered Alloy Steel.
- At least 25% greater WLL than traditional G80 products.
- Manufactured in accordance with EN 1677- 2 and ASME B30.26, ASME B30.10, PAS1061.
- Certified by DGUV GS-OA-15-05
- Proof Load tested at 2.5 times the WLL with certification for each batch manufactured.
- Design Factor 4:1.
- Fatigue rated to 20,000 cycles at 1.5 times the WLL.
- Tempering temperature minimum 400°C
- Magnaflux crack detection is performed 100% on each batch.



8-P044
Repair kit available

G-100 Eye Sling Hook

with Latch

| Item No. | For Grade 100 Chain mm | WLL tonnes* | Dimensions (mm) | | | | | | N.W. kg |
|------------|---------------------------------|----------------|-----------------|----|----|-----|-----|----|------------|
| | | | A | D | H | K | P1 | T | |
| X-044/S-06 | 6 | 1.4 | 20 | 10 | 19 | 80 | 23 | 17 | 0.3 |
| X-044/S-07 | 7,8 | 2.5 | 25 | 12 | 22 | 98 | 28 | 20 | 0.5 |
| X-044/S-10 | 10 | 4.0 | 33 | 15 | 30 | 122 | 36 | 23 | 1.0 |
| X-044/S-13 | 13 | 6.7 | 40 | 18 | 38 | 152 | 40 | 28 | 1.8 |
| X-044/S-16 | 16 | 10.0 | 51 | 22 | 44 | 185 | 44 | 36 | 3.4 |
| X-044/S-20 | 20 | 16.0 | 61 | 27 | 64 | 230 | 54 | 48 | 7.3 |
| X-044/S-22 | 22 | 19.0 | 51 | 31 | 61 | 245 | 76 | 52 | 9.3 |
| X-044/S-26 | 26 | 26.5 | 65 | 34 | 77 | 285 | 77 | 61 | 13.5 |
| X-044/S-32 | 32 | 40.0 | 91 | 41 | 79 | 358 | 114 | 65 | 22.0 |

★ Design factor 4:1 proof tested and certified.

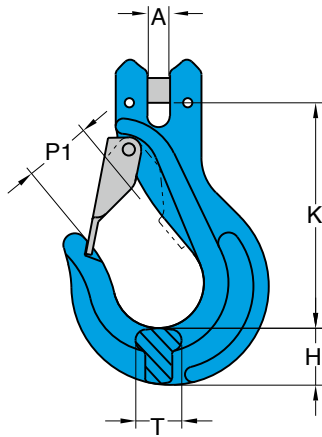

- Quenched and Tempered Alloy Steel.
- At least 25% greater WLL than traditional G80 products.
- Manufactured in accordance with EN 1677- 2 and ASME B30.26, ASME B30.10, PAS1061.
- Certified by DGUV GS-OA-15-05
- Proof Load tested at 2.5 times the WLL with certification for each batch manufactured.
- Design Factor 4:1.
- Fatigue rated to 20,000 cycles at 1.5 times the WLL.
- Tempering temperature minimum 400°C
- Magnaflux crack detection is performed 100% on each batch.



X-P026
For load pin replacement



8-P044
For latch replacement

G-100 Clevis Sling Hook

with Latch

| Item No. | For Grade 100 Chain | WLL tonnes* | Dimensions (mm) | | | | | N.W. kg |
|------------|---------------------|----------------|-----------------|----|-----|----|----|------------|
| | mm | | A | H | K | P1 | T | |
| X-043/S-06 | 6 | 1.4 | 7 | 18 | 79 | 23 | 15 | 0.3 |
| X-043/S-07 | 7,8 | 2.5 | 9 | 22 | 98 | 27 | 18 | 0.6 |
| X-043/S-10 | 10 | 4.0 | 12 | 30 | 122 | 34 | 24 | 1.1 |
| X-043/S-13 | 13 | 6.7 | 15 | 37 | 147 | 44 | 30 | 2.3 |
| X-043/S-16 | 16 | 10.0 | 17 | 41 | 166 | 48 | 39 | 3.8 |
| X-043/S-20 | 20 | 16.0 | 24 | 64 | 207 | 57 | 48 | 8.7 |
| X-043/S-22 | 22 | 19.0 | 25 | 61 | 217 | 73 | 52 | 9.5 |

★ Design factor 4:1 proof tested and certified.

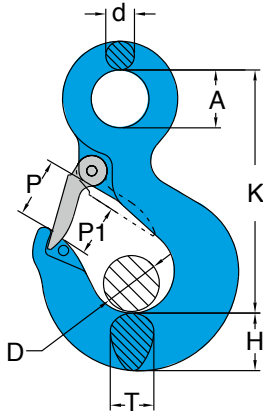

- Quenched and Tempered Alloy Steel.
- At least 25% greater WLL than traditional G80 products.
- Manufactured in accordance with EN 1677- 2 and ASME B30.26.
- Proof Load tested at 2.5 times the WLL with certification for each batch manufactured.
- Design Factor 4:1.
- Fatigue rated to 20,000 cycles at 1.5 times the WLL.
- Tempering temperature minimum 400°C
- Magnaflux crack detection is performed 100% on each batch.



For latch replacement

X-173 G-100 Eye Hook

| Item No. | Hook Feature Code | For Grade 100 Chain | WLL | Dimensions (mm) | | | | | | | | N.W. |
|----------|-------------------|---------------------|------|-----------------|---------|----|----|-----|----|----|----|------|
| | | | | mm | tonnes* | A | D | d | H | K | P | |
| X-173-05 | AA | 5.0 | 1.0 | 23 | 22 | 10 | 22 | 83 | 26 | 22 | 16 | 0.3 |
| X-173-06 | BB | 6.0 | 1.4 | 23 | 19 | 11 | 22 | 95 | 23 | 19 | 17 | 0.4 |
| X-173-07 | CC | 7, 8 | 2.5 | 29 | 20 | 13 | 27 | 106 | 24 | 20 | 22 | 0.7 |
| X-173-10 | DD | 10.0 | 4.0 | 32 | 25 | 15 | 29 | 122 | 28 | 25 | 24 | 0.9 |
| X-173-13 | EE | 13.0 | 6.7 | 41 | 31 | 18 | 37 | 149 | 36 | 31 | 31 | 2.0 |
| X-173-16 | FF | 16.0 | 10.0 | 51 | 38 | 24 | 48 | 192 | 42 | 39 | 37 | 4.0 |
| X-173-20 | GG | 20.0 | 16.0 | 63 | 57 | 28 | 56 | 233 | 61 | 57 | 47 | 7.0 |
| X-173-22 | HH | 22.0 | 19.0 | 73 | 62 | 32 | 64 | 260 | 68 | 62 | 52 | 9.4 |
| X-173-26 | JJ | 26.5 | 26.5 | 91 | 81 | 40 | 74 | 318 | 92 | 81 | 68 | 18.7 |
| X-173-32 | KK | 32.0 | 40.0 | 91 | 83 | 45 | 92 | 347 | 89 | 83 | 76 | 31.3 |

★ Design factor 4:1 proof tested and certified.

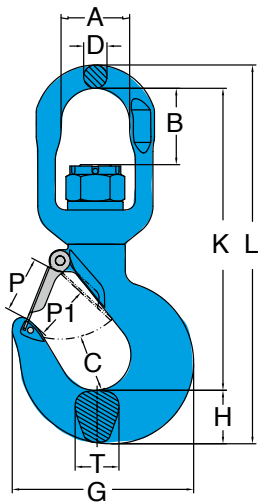

- Quenched and Tempered Alloy Steel.
- At least 25% greater WLL than traditional G80 products.
- Manufactured in accordance with EN 1677- 2 and ASME B30.26.
- Proof Load tested at 2.5 times the WLL with certification for each batch manufactured.
- Design Factor 4:1.
- Fatigue rated to 20,000 cycles at 1.5 times the WLL.
- Tempering temperature minimum 400°C
- Magnaflux crack detection is performed 100% on each batch.

X-175 G-100 Swivel Hook

| Item No. | Hook Feature Code | For Grade 100 Chain mm | WLL tonnes* | Dimensions (mm) | | | | | | | | | | N.W. kg | |
|----------|-------------------|---------------------------|----------------|-----------------|-----|----|----|-----|----|-----|-----|----|----|------------|------|
| | | | | A | B | C | D | G | H | K | L | P | P1 | | T |
| X-175-05 | AA | 5 | 1.0 | 32 | 23 | 25 | 12 | 73 | 19 | 125 | 156 | 24 | 22 | 17 | 0.6 |
| X-175-06 | BB | 6 | 1.4 | 32 | 25 | 25 | 12 | 81 | 23 | 131 | 165 | 24 | 19 | 22 | 0.7 |
| X-175-07 | CC | 7, 8 | 2.5 | 36 | 30 | 26 | 13 | 90 | 27 | 145 | 184 | 24 | 20 | 22 | 1.0 |
| X-175-10 | DD | 10 | 4.0 | 41 | 38 | 29 | 16 | 102 | 29 | 172 | 217 | 28 | 25 | 24 | 1.5 |
| X-175-13 | EE | 13 | 6.7 | 46 | 48 | 38 | 21 | 122 | 38 | 218 | 277 | 35 | 31 | 31 | 3.2 |
| X-175-16 | FF | 16 | 10.0 | 61 | 56 | 49 | 23 | 160 | 48 | 261 | 332 | 43 | 39 | 35 | 5.6 |
| X-175-20 | GG | 18-20 | 16.0 | 74 | 86 | 62 | 25 | 196 | 56 | 327 | 410 | 61 | 57 | 47 | 9.6 |
| X-175-22 | HH | 22 | 19.0 | 97 | 98 | 65 | 33 | 221 | 64 | 372 | 471 | 72 | 62 | 56 | 15.9 |
| X-175-26 | JJ | 26 | 26.5 | 123 | 116 | 71 | 51 | 277 | 76 | 469 | 599 | 86 | 81 | 68 | 33.4 |
| X-175-32 | KK | 32 | 40.0 | 123 | 116 | 87 | 51 | 353 | 93 | 503 | 651 | 89 | 83 | 76 | 45.6 |

★ Design factor 4:1 proof tested and certified.

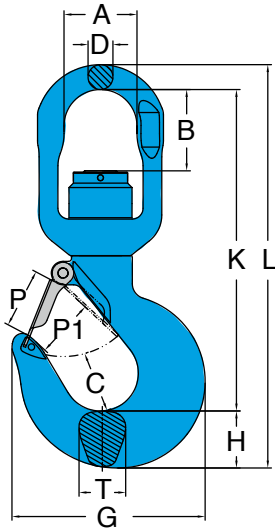

- Quenched and Tempered Alloy Steel.
- At least 25% greater WLL than traditional G80 products.
- Manufactured in accordance with EN 1677- 2 and ASME B30.26.
- Proof Load tested at 2.5 times the WLL with certification for each batch manufactured.
- Design Factor 4:1.
- Fatigue rated to 20,000 cycles at 1.5 times the WLL.
- Tempering temperature minimum 400°C
- Magnaflux crack detection is performed 100% on each batch.
- Built with ball bearing and enables full swivel feature under load.

X-175N G-100 Swivel Bearing Hook

| Item No. | Hook Feature Code | For Grade 100 Chain | WLL | Dimensions (mm) | | | | | | | | | | | N.W. |
|-----------|-------------------|---------------------|------|-----------------|---------|----|----|-----|----|-----|-----|----|----|----|------|
| | | | | mm | tonnes* | A | B | C | D | G | H | K | L | P | |
| X-175N-05 | AA | 5 | 1.0 | 32 | 23 | 25 | 12 | 73 | 19 | 125 | 156 | 24 | 22 | 17 | 0.6 |
| X-175N-06 | BB | 6 | 1.4 | 32 | 23 | 25 | 12 | 81 | 23 | 131 | 165 | 24 | 19 | 17 | 0.7 |
| X-175N-07 | CC | 7, 8 | 2.5 | 36 | 29 | 26 | 13 | 90 | 27 | 145 | 184 | 24 | 20 | 22 | 1.0 |
| X-175N-10 | DD | 10 | 4.0 | 41 | 35 | 29 | 16 | 102 | 29 | 172 | 217 | 28 | 25 | 24 | 1.6 |
| X-175N-13 | EE | 13 | 6.7 | 46 | 44 | 38 | 21 | 122 | 38 | 218 | 277 | 35 | 31 | 31 | 3.3 |
| X-175N-16 | FF | 16 | 10.0 | 61 | 50 | 49 | 23 | 160 | 48 | 261 | 332 | 43 | 39 | 35 | 5.6 |
| X-175N-20 | GG | 18-20 | 16.0 | 74 | 82 | 62 | 25 | 196 | 56 | 327 | 410 | 61 | 57 | 47 | 9.5 |
| X-175N-22 | HH | 22 | 19.0 | 97 | 96 | 65 | 33 | 221 | 64 | 372 | 471 | 72 | 62 | 56 | 16.0 |
| X-175N-26 | JJ | 26 | 26.5 | 123 | 116 | 71 | 51 | 277 | 76 | 469 | 599 | 86 | 81 | 68 | 33.5 |
| X-175N-32 | KK | 32 | 40.0 | 123 | 116 | 87 | 51 | 353 | 93 | 503 | 651 | 89 | 83 | 76 | 45.0 |

★ Design factor 4:1 proof tested and certified.

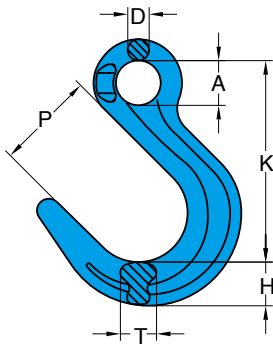

- Quenched and Tempered Alloy Steel.
- At least 25% greater WLL than traditional G80 products.
- Manufactured in accordance with DIN PAS 1061 and ASTM A952/A 952M, EN 1677- 1.
- Certified by DGUV GS-OA-15-05
- Proof Load tested at 2.5 times the WLL with certification for each batch manufactured.
- Design Factor 4:1.
- Fatigue rated to 20,000 cycles at 1.5 times the WLL.
- Tempering temperature minimum 400°C
- Designed for the assembly of chain slings where wide throat openings are necessary.
- Before using the hook, check whether hooks without safety latches are allowed to be used for the particular application.

G-100 Eye Foundry Hook

| Item No. | For Grade 100 Chain | WLL tonnes* | Dimensions (mm) | | | | | | N.W. kg |
|----------|---------------------------|----------------|-----------------|----|----|-----|-----|----|------------|
| | mm | | A | D | H | K | P | T | |
| X-047-07 | 7,8 | 2.5 | 24 | 12 | 30 | 123 | 62 | 19 | 0.8 |
| X-047-10 | 10 | 4.0 | 32 | 15 | 35 | 149 | 74 | 29 | 1.6 |
| X-047-13 | 13 | 6.7 | 40 | 19 | 39 | 180 | 88 | 32 | 2.6 |
| X-047-16 | 16 | 10.0 | 50 | 25 | 46 | 215 | 101 | 41 | 4.5 |
| X-047-20 | 20 | 16.0 | 60 | 26 | 59 | 248 | 113 | 58 | 9.3 |

★ Design factor 4:1 proof tested and certified.

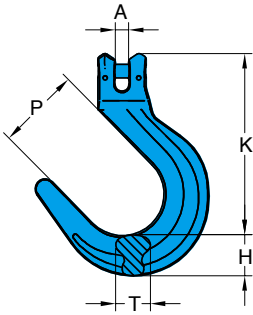

- Quenched and Tempered Alloy Steel.
- At least 25% greater WLL than traditional G80 products.
- Manufactured in accordance with DIN PAS 1061 and ASTM A952/A 952M, EN 1677- 1.
- Certified by DGUV GS-OA-15-05
- Design Factor 4:1.
- Fatigue rated to 20,000 cycles at 1.5 times the WLL.
- Tempering temperature minimum 400°C
- Designed for the assembly of chain slings where wide throat openings are necessary.
- Before using the hook, check whether hooks without safety latches are allowed to be used for the particular application.



X-P026

For load pin replacement

G-100 Clevis Foundry Hook

| Item No. | For Grade 100 Chain | WLL tonnes* | Dimensions (mm) | | | | | N.W. kg |
|----------|---------------------------|----------------|-----------------|----|-----|-----|----|------------|
| | mm | | A | H | K | P | T | |
| X-046-07 | 7,8 | 2.5 | 10 | 30 | 133 | 62 | 20 | 0.95 |
| X-046-10 | 10 | 4.0 | 12 | 35 | 162 | 74 | 29 | 1.80 |
| X-046-13 | 13 | 6.7 | 15 | 39 | 180 | 88 | 32 | 3.60 |
| X-046-16 | 16 | 10.0 | 18 | 46 | 216 | 101 | 41 | 6.40 |
| X-046-20 | 20 | 16.0 | 24 | 59 | 279 | 116 | 57 | 11.20 |

★ Design factor 4:1 proof tested and certified.

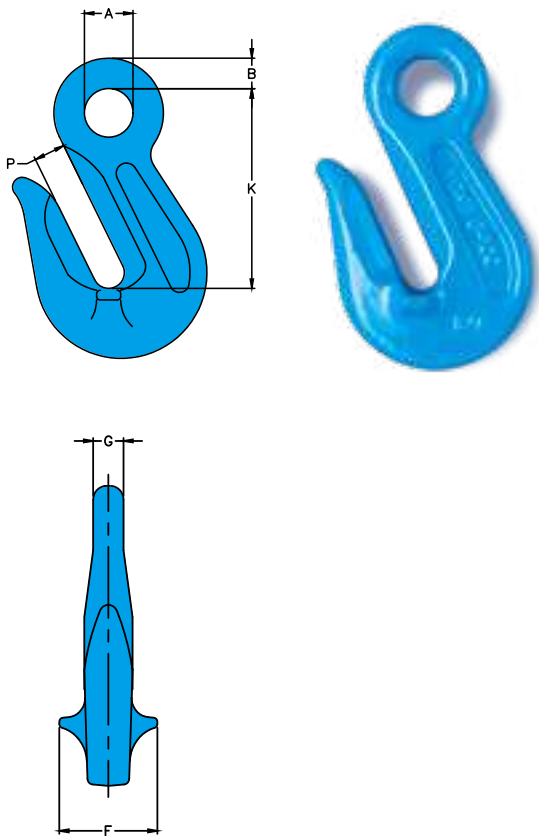

- Quenched and Tempered Alloy Steel.
- At least 25% greater WLL than traditional G80 products.
- Manufactured in accordance with DIN 5692, EN 1677-1 and ASTM A952/A 952M.
- Certified by DGUV GS-MO-15-05.
- Proof Load tested at 2.5 times the WLL with certification for each batch manufactured.
- Design Factor 4:1.
- Fatigue rated to 20,000 cycles at 1.5 times the WLL.
- Tempering temperature minimum 400°C
- Not for use with Omega Link
- Enables full WLL while in use, thanks to supporting wings which prevent chain link deformation.

G-100 Eye Grab Hook

| Item No. | For Grade 100 Chain | | Dimensions (mm) | | | | | | N.W. kg |
|----------|---------------------|---------|-----------------|----|-----|----|-----|----|------------|
| | mm | tonnes* | A | B | F | G | K | P | |
| X-041-06 | 6 | 1.4 | 13 | 7 | 26 | 8 | 50 | 8 | 0.2 |
| X-041-07 | 7,8 | 2.5 | 16 | 10 | 30 | 9 | 62 | 10 | 0.3 |
| X-041-10 | 10 | 4.0 | 20 | 13 | 40 | 13 | 82 | 13 | 0.6 |
| X-041-13 | 13 | 6.7 | 26 | 16 | 52 | 16 | 107 | 17 | 1.4 |
| X-041-16 | 16 | 10.0 | 30 | 18 | 70 | 20 | 132 | 21 | 2.4 |
| X-041-20 | 20 | 16.0 | 40 | 22 | 73 | 24 | 148 | 24 | 4.0 |
| X-041-22 | 22 | 19.0 | 42 | 24 | 86 | 26 | 166 | 26 | 5.0 |
| X-041-26 | 26 | 26.5 | 50 | 30 | 110 | 32 | 207 | 33 | 10.0 |
| X-041-32 | 32 | 40.0 | 62 | 37 | 130 | 42 | 266 | 42 | 24.0 |

★ Design factor 4:1 proof tested and certified.

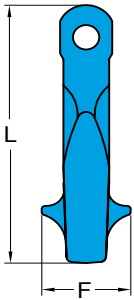
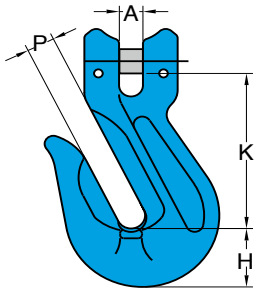

- Quenched and Tempered Alloy Steel.
- At least 25% greater WLL than traditional G80 products.
- Manufactured in accordance with DIN PAS 1061, EN 1677-1 and ASTM A952/A 952M.
- Certified by DGUV GS-OA-15-05.
- Proof Load tested at 2.5 times the WLL with certification for each batch manufactured.
- Design Factor 4:1.
- Fatigue rated to 20,000 cycles at 1.5 times the WLL.
- Tempering temperature minimum 400°C
- Not for use with Omega Link
- Enables full WLL while in use, thanks to supporting wings which prevent chain link deformation.



X-P026

For load pin replacement

G-100 Clevis Grab Hook

| Item No. | For Grade 100 Chain | | Dimensions (mm) | | | | | | N.W. kg |
|----------|---------------------|---------|-----------------|----|----|-----|-----|----|------------|
| | mm | tonnes* | A | F | H | K | L | P | |
| X-042-06 | 6 | 1.4 | 7 | 25 | 18 | 47 | 79 | 8 | 0.2 |
| X-042-07 | 7,8 | 2.5 | 10 | 30 | 22 | 54 | 93 | 10 | 0.4 |
| X-042-10 | 10 | 4.0 | 11 | 41 | 29 | 78 | 128 | 13 | 0.8 |
| X-042-13 | 13 | 6.7 | 15 | 52 | 38 | 99 | 165 | 17 | 1.6 |
| X-042-16 | 16 | 10.0 | 18 | 57 | 45 | 114 | 195 | 21 | 2.7 |
| X-042-20 | 20 | 16.0 | 22 | 73 | 52 | 130 | 222 | 24 | 4.8 |
| X-042-22 | 22 | 19.0 | 24 | 70 | 56 | 139 | 247 | 26 | 6.4 |

★ Design factor 4:1 proof tested and certified.

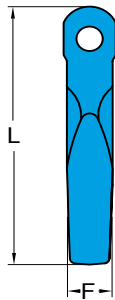
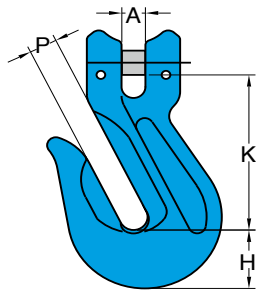

- Quenched and Tempered Alloy Steel.
- At least 25% greater WLL than traditional G80 products.
- Manufactured in accordance with DIN PAS 1061, EN 1677-1 and ASTM A952/A 952M.
- Certified by DGUV GS-OA-15-05.
- Proof Load tested at 2.5 times the WLL with certification for each batch manufactured.
- Design Factor 4:1.
- Fatigue rated to 20,000 cycles at 1.5 times the WLL.
- Tempering temperature minimum 400°C
- Not for use with Omega Link
- Enables full WLL while in use, thanks to supporting wings which prevent chain link deformation.

G-100 Clevis Grab Hook - Without Cradle

| Item No. | For Grade 100 Chain | WLL tonnes* | Dimensions (mm) | | | | | | N.W. kg |
|------------------|---------------------------|----------------|-----------------|----|----|-----|-----|----|------------|
| | mm | | A | F | H | K | L | P | |
| X-0421-07 | 7,8 | 2.5 | 10 | 16 | 22 | 54 | 93 | 10 | 0.4 |
| X-0421-10 | 10 | 4.0 | 12 | 21 | 29 | 77 | 128 | 13 | 0.8 |
| X-0421-13 | 13 | 6.7 | 15 | 26 | 38 | 99 | 165 | 17 | 1.6 |
| X-0421-16 | 16 | 10.0 | 18 | 33 | 45 | 114 | 195 | 21 | 2.7 |

★ Design factor 4:1 proof tested and certified.

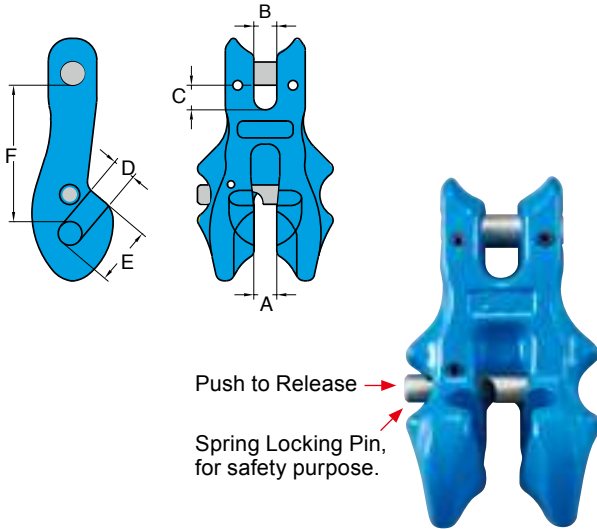

- Quenched and Tempered Alloy Steel.
- At least 25% greater WLL than traditional G80 products.
- Manufactured in accordance with EN 1677- 1 and ASME B30.26.
- Proof Load tested at 2.5 times the WLL with certification for each batch manufactured.
- Design Factor 4:1.
- Fatigue rated to 20,000 cycles at 1.5 times the WLL.
- Tempering temperature minimum 400°C
- The use of Clevis Clutch still allows 100% of the chain sling capacity.
- With the locking system and spring locking pin design to enhance security and prevent the chains from disengaging.

G-100 Clevis Clutch - Locking Type

| Item No. | For Grade 100 Chain | | Dimensions (mm) | | | | | | N.W. kg |
|----------|---------------------|--------|-----------------|----|----|----|----|-----|------------|
| | mm | tonnes | A | B | C | D | E | F | |
| X-061-07 | 7, 8 | 2.5 | 10 | 10 | 10 | 10 | 24 | 58 | 0.5 |
| X-061-10 | 10 | 4.0 | 12 | 12 | 12 | 12 | 34 | 71 | 1.0 |
| X-061-13 | 13 | 6.7 | 15 | 15 | 16 | 15 | 40 | 92 | 2.2 |
| X-061-16 | 16 | 10.0 | 21 | 18 | 18 | 19 | 48 | 103 | 3.9 |

★ Design factor 4:1 proof tested and certified.

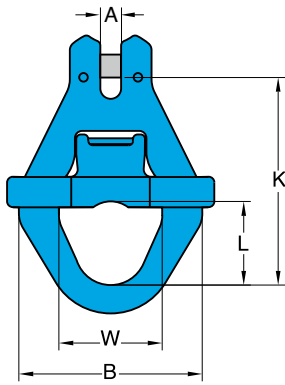

- Quenched and Tempered Alloy Steel.
- At least 25% greater WLL than traditional G80 products.
- Manufactured in accordance with EN 1677- 1 and ASME B30.26.
- Proof Load tested at 2.5 times the WLL with certification for each batch manufactured.
- Design Factor 4:1.
- Fatigue rated to 20,000 cycles at 1.5 times the WLL.
- Tempering temperature minimum 400°C
- The use of Clevis Clutch still allows 100% of the chain sling capacity.
- With the locking system and spring locking pin design to enhance security and prevent the chains from disengaging.

G-100 Clevis Container Hook

| Item No. | For Grade 100 Chain | WLL tonnes | Dimensions (mm) | | | | | N.W. kg |
|-----------------|---------------------------|---------------|-----------------|-----|-----|----|----|------------|
| | mm | | A | B | K | L | W | |
| X-069-10 | 10 | 4.0 | 12 | 125 | 138 | 57 | 65 | 1.6 |
| X-069-13 | 13 | 6.7 | 15 | 125 | 146 | 57 | 65 | 1.8 |

★ Design factor 4:1 proof tested and certified.



Quality Management System:





TAIWAN
EXCELLENCE 2021

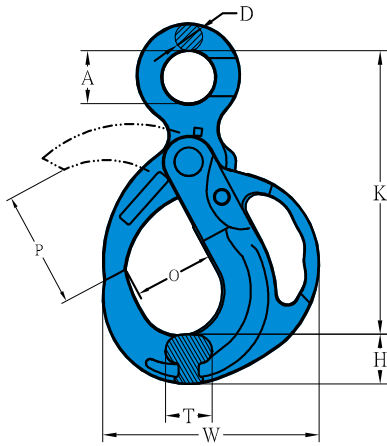

- Quenched and Tempered Alloy Steel.
- Manufactured in accordance with EN 1677- 3.
- Manufactured in accordance with ASTM A952/A952M, DIN PAS 1061.
- Proof Load tested at 2.5 times the WLL with certification for each batch manufactured.
- Design Factor 4:1.
- Fatigue rated to 20,000 cycles at 1.5 times the WLL.
- Tempering temperature minimum 400°C
- Magnaflux crack detection is performed 100% on each batch.

» American Patent



X-P950

For push lock replacement

G-100 Eye Grip Safe Locking Hook

| Item No. | For Grade 100 Chain | WLL tonnes* | Dimensions (mm) | | | | | | | | N.W. kg |
|----------|---------------------------|----------------|-----------------|----|----|-----|----|-----|----|-----|------------|
| | mm | | A | D | H | K | O | P | T | W | |
| X-950-10 | 10 | 4.0 | 33 | 13 | 31 | 176 | 49 | 71 | 27 | 137 | 1.9 |
| X-950-13 | 13 | 6.7 | 40 | 16 | 39 | 226 | 64 | 80 | 34 | 174 | 4.0 |
| X-950-16 | 16 | 10.0 | 50 | 21 | 47 | 277 | 78 | 114 | 39 | 212 | 6.3 |
| X-950-20 | 20 | 16.0 | 62 | 23 | 55 | 329 | 92 | 127 | 54 | 251 | 12.3 |
| X-950-22 | 22 | 19.0 | 70 | 24 | 59 | 350 | 98 | 151 | 56 | 258 | 14.0 |

★ Design factor 4:1 proof tested and certified

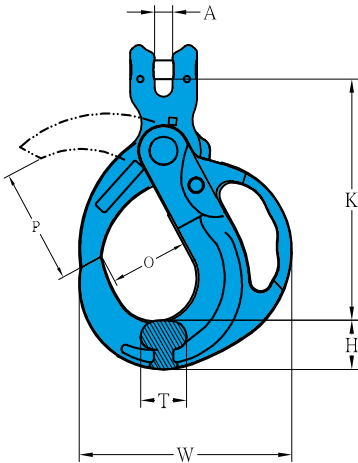

- Quenched and Tempered Alloy Steel.
- Manufactured in accordance with EN 1677- 3.
- Manufactured in accordance with ASTM A952/A952M, DIN PAS 1061.
- Proof Load tested at 2.5 times the WLL with certification for each batch manufactured.
- Fatigue rated to 20,000 cycles at 1.5 times the WLL.
- Tempering temperature minimum 400°C
- Magnaflux crack detection is performed 100% on each batch.

» American Patent

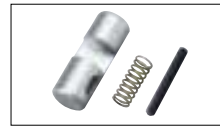

X-P950

For push lock replacement

G-100 Clevis Grip Safe Locking Hook

| Item No. | For Grade 100 Chain | WLL tonnes* | Dimensions (mm) | | | | | | | N.W. kg |
|----------|---------------------------|----------------|-----------------|----|-----|----|-----|----|-----|------------|
| | mm | | A | H | K | O | P | T | W | |
| X-951-10 | 10 | 4.0 | 12.1 | 31 | 153 | 49 | 71 | 27 | 137 | 1.9 |
| X-951-13 | 13 | 6.7 | 15.5 | 39 | 203 | 64 | 80 | 34 | 174 | 4.1 |
| X-951-16 | 16 | 10.0 | 19.1 | 47 | 244 | 78 | 114 | 39 | 212 | 7.1 |
| X-951-20 | 20 | 16.0 | 24 | 55 | 312 | 92 | 127 | 54 | 251 | 12.7 |
| X-951-22 | 22 | 19.0 | 24.2 | 59 | 304 | 98 | 151 | 56 | 258 | 14.1 |

★ Design factor 4:1 proof tested and certified

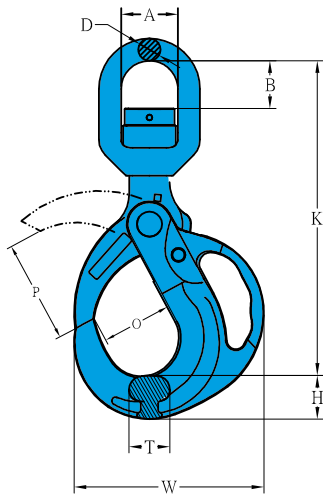

- Quenched and Tempered Alloy Steel.
- Manufactured in accordance with EN 1677- 3.
- Manufactured in accordance with ASTM A952/A952M, DIN PAS 1061.
- Proof Load tested at 2.5 times the WLL with certification for each batch manufactured.
- Design Factor 4:1.
- Fatigue rated to 20,000 cycles at 1.5 times the WLL.
- Tempering temperature minimum 400°C
- Magnaflux crack detection is performed 100% on each batch.
- Built with ball bearing and enables full swivel feature under load.

» American Patent



X-P950

For push lock replacement

G-100 Swivel Grip Safe Locking Hook

| Item No. | For Grade 100 Chain | WLL tonnes* | Dimensions (mm) | | | | | | | | | N.W. kg |
|------------------|---------------------------|----------------|-----------------|----|----|----|-----|----|-----|----|-----|------------|
| | mm | | A | B | D | H | K | O | P | T | W | |
| X-952N-10 | 10 | 4.0 | 41 | 35 | 16 | 31 | 226 | 49 | 71 | 27 | 137 | 2.4 |
| X-952N-13 | 13 | 6.7 | 46 | 44 | 21 | 39 | 283 | 64 | 80 | 34 | 174 | 5.2 |
| X-952N-16 | 16 | 10.0 | 61 | 50 | 23 | 47 | 347 | 78 | 114 | 39 | 212 | 8.4 |
| X-952N-20 | 20 | 16.0 | 74 | 82 | 25 | 55 | 433 | 92 | 127 | 54 | 251 | 14.5 |
| X-952N-22 | 22 | 19.0 | 97 | 96 | 33 | 59 | 476 | 98 | 151 | 56 | 258 | 20.4 |

★ Design factor 4:1 proof tested and certified

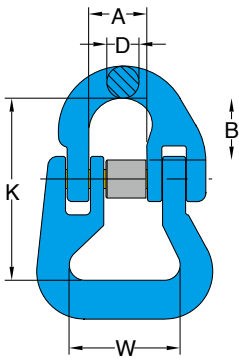

- Quenched and Tempered Alloy Steel.
- At least 25% greater WLL than traditional G80 products.
- Manufactured in accordance with EN 1677- 1, PAS1061 and ASME B30.26.
- Certified by DGUV GS-OA-15-05.
- Proof Load tested at 2.5 times the WLL with certification for each batch manufactured.
- Design Factor 4:1.
- Fatigue rated to 20,000 cycles at 1.5 times the WLL.
- Tempering temperature minimum 400°C
- Magnaflux crack detection is performed 100% on each batch.

G-100 Web Sling Connector

| Item No. | WLL tonnes* | Dimensions (mm) | | | | | N.W. kg |
|----------|----------------|-----------------|----|----|-----|-----|------------|
| | | A | B | D | K | W | |
| X-016-06 | 1.4 | 15 | 17 | 7 | 56 | 39 | 0.2 |
| X-016-07 | 2.5 | 18 | 23 | 9 | 63 | 39 | 0.3 |
| X-016-10 | 4.0 | 25 | 27 | 11 | 77 | 46 | 0.6 |
| X-016-13 | 6.7 | 30 | 37 | 16 | 97 | 53 | 1.1 |
| X-016-16 | 10.0 | 36 | 39 | 19 | 114 | 66 | 2.0 |
| X-016-20 | 16.0 | 42 | 46 | 23 | 132 | 79 | 3.2 |
| X-016-22 | 19.0 | 49 | 59 | 24 | 188 | 124 | 7.7 |

★ Design factor 4:1 proof tested and certified.

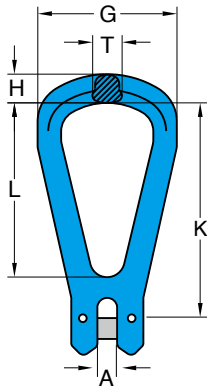

- Quenched and Tempered Alloy Steel.
- At least 25% greater WLL than traditional G80 products.
- Manufactured in accordance with EN 1677- 1 and ASME B30.26.
- Proof Load tested at 2.5 times the WLL with certification for each batch manufactured.
- Design Factor 4:1.
- Fatigue rated to 20,000 cycles at 1.5 times the WLL.
- Tempering temperature minimum 400°C
- Magnaflux crack detection is performed 100% on each batch.

G-100 Clevis Master Link

| Item No. | For Grade 100 Chain | WLL tonnes* | Dimensions (mm) | | | | | | N.W. kg |
|----------|---------------------------|----------------|-----------------|-----|----|-----|-----|----|------------|
| | mm | | A | G | H | K | L | T | |
| X-059-07 | 7,8 | 2.5 | 10 | 65 | 15 | 103 | 83 | 19 | 0.4 |
| X-059-10 | 10 | 4.0 | 11 | 96 | 19 | 133 | 108 | 19 | 0.8 |
| X-059-13 | 13 | 6.7 | 15 | 108 | 22 | 168 | 136 | 25 | 1.5 |
| X-059-16 | 16 | 10.0 | 18 | 124 | 26 | 203 | 165 | 27 | 2.4 |

★ Design factor 4:1 proof tested and certified

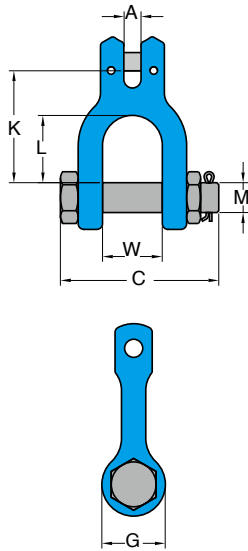

- Quenched and Tempered Alloy Steel.
- At least 25% greater WLL than traditional G80 products.
- Manufactured in accordance with EN 1677- 1 and ASME B30.26.
- Proof Load tested at 2.5 times the WLL with certification for each batch manufactured.
- Design Factor 4:1.
- Fatigue rated to 20,000 cycles at 1.5 times the WLL.
- Tempering temperature minimum 400°C
- Magnaflux crack detection is performed 100% on each batch.

G-100 Clevis Shackle

| Item No. | For Grade 100 Chain | WLL tonnes* | Dimensions (mm) | | | | | | | N.W. kg |
|----------|---------------------------|----------------|-----------------|-----|----|-----|----|----|----|------------|
| | mm | | A | C | G | K | L | M | W | |
| X-066-07 | 7,8 | 2.5 | 10 | 81 | 34 | 60 | 36 | 16 | 32 | 0.4 |
| X-066-10 | 10 | 4.0 | 12 | 94 | 40 | 78 | 48 | 20 | 34 | 0.8 |
| X-066-13 | 13 | 6.7 | 15 | 121 | 44 | 98 | 64 | 22 | 50 | 1.4 |
| X-066-16 | 16 | 10.0 | 18 | 140 | 55 | 112 | 67 | 28 | 60 | 2.5 |

★ Design factor 4:1 proof tested and certified

G-100 Coupling Pin & Sleeve Set.

for X-015



| Item No. | Size | | Working Load Limit tonnes* |
|-----------|------------|-------|-------------------------------|
| | inch | mm | |
| X-P015-06 | 7/32 | 6 | 1.4 |
| X-P015-07 | 1/4 - 5/16 | 7 | 2.5 |
| X-P015-10 | 3/8 | 10 | 4.0 |
| X-P015-13 | 1/2 | 13 | 6.7 |
| X-P015-16 | 5/8 | 16 | 10.0 |
| X-P015-20 | 3/4 | 18,20 | 16.0 |
| X-P015-22 | 7/8 | 22 | 19.0 |
| X-P015-26 | 1 | 26 | 26.5 |
| X-P015-32 | 1 1/4 | 32 | 40.0 |

Latch Kits.

for 8-044, 8-043, X-044,
X-043



| Item No. | Size | | Working Load Limit tonnes* |
|-----------|------------|-------|-------------------------------|
| | inch | mm | |
| 8-P044-06 | 7/32 | 6 | 1.4 |
| 8-P044-07 | 1/4 - 5/16 | 7 | 2.5 |
| 8-P044-10 | 3/8 | 10 | 4.0 |
| 8-P044-13 | 1/2 | 13 | 6.7 |
| 8-P044-16 | 5/8 | 16.0 | 10.0 |
| 8-P044-20 | 3/4 | 18,20 | 16.0 |
| 8-P044-22 | 7/8 | 22 | 19.0 |
| 8-P044-26 | 1 | 26 | 26.5 |
| 8-P044-32 | 1 1/4 | 32 | 40.0 |

G-100 Load Pin Kits

for X-026 , X-042 , X-043 , X-046



| Item No. | Size | | Working Load Limit tonnes* |
|-----------|------------|-------|-------------------------------|
| | inch | mm | |
| X-P026-06 | 7/32 | 6 | 1.4 |
| X-P026-07 | 1/4 - 5/16 | 7 | 1.5 |
| X-P026-10 | 3/8 | 10 | 4.0 |
| X-P026-13 | 1/2 | 13 | 6.7 |
| X-P026-16 | 5/8 | 16 | 10.0 |
| X-P026-20 | 3/4 | 18,20 | 16.0 |
| X-P026-22 | 7/8 | 22 | 19.0 |

Trigger Kits For Grip Self Locking Hooks

For X-950, X-951, X-952N



| Item No. | Size | | Working Load Limit tonnes* |
|-----------|------|-------|-------------------------------|
| | inch | mm | |
| X-P950-10 | 3/8 | 10 | 4.0 |
| X-P950-13 | 1/2 | 13 | 6.7 |
| X-P950-16 | 5/8 | 16 | 10.0 |
| X-P950-20 | 3/4 | 20,22 | 16.0 |

Trigger Kits for G80 and G100 Self Locking Hooks



| Item No. | Size | |
|-----------|----------|-------|
| | inch | mm |
| 8-P025-06 | 7/32 | 6 |
| 8-P025-07 | 1/4-5/16 | 7 |
| 8-P025-10 | 3/8 | 10 |
| 8-P025-13 | 1/2 | 13 |
| 8-P025-16 | 5/8 | 16 |
| 8-P025-20 | 3/4 | 18,20 |
| 8-P025-22 | 7/8 | 22 |
| 8-P025-26 | 1 | 26 |
| 8-P025-28 | 1-1/8 | 28 |

**For G100 size 20mm: X-P025-20

Index by Part No.

| Product No. | Repair Kits No. |
|-------------|-----------------|
| X-025-06 | 8-P025-06 |
| X-025-07 | 8-P025-07 |
| X-025-10 | 8-P025-10 |
| X-025-13 | 8-P025-13 |
| X-025-16 | 8-P025-16 |
| X-025-20 | X-P025-20 |
| X-025-22 | 8-P025-22 |
| X-025-26 | 8-P025T-26 |
| X-025-28 | 8-P025-28 |
| 8-025-06 | 8-P025-06 |
| 8-025-07 | 8-P025-07 |
| 8-025-10 | 8-P025-10 |
| 8-025-13 | 8-P025-13 |
| 8-025-16 | 8-P025-16 |
| 8-025-20 | 8-P025T-20 |
| 8-025-22 | 8-P025-22 |
| 8-025-26 | 8-P025T-26 |
| 8-025-28 | 8-P025T-28 |

New Trigger Kits for Self Locking Hooks size 20mm, 26mm, and 28mm after design change



| G80 size 20mm | | |
|------------------------|-------|-------|
| Item No. | Size | |
| | inch | mm |
| 8-P025T-20 | 3/4 | 18,20 |
| G80 and G100 size 26mm | | |
| Item No. | Size | |
| | inch | mm |
| 8-P025T-26 | 1 | 26 |
| G80 size 28mm | | |
| Item No. | Size | |
| | inch | mm |
| 8-P025T-28 | 1-1/8 | 28 |



DISCOVERY VIDEO



DANGER: Overhead lifting presents a very real danger of severe injury or loss of life if lifting equipment is not used properly. Please read and understand all of these instructions prior to using any lifting sling or sling assembly. Sling should only be used by qualified persons who are responsible for the sling selection, inspection and use.

Grade 80 Chain Sling Components

| WORKING LOAD LIMITS IN TONNES acc. to EN1677 | | | | | | |
|--|--------|-------------------------------------|-------------------------|-------------------------------------|-------------------------|------|
| | | | | | | |
| For Chain Size mm | tonnes | β 0 - 45° α 0 - 90° | 45° - 60° 90° - 120° | β 0 - 45° α 0 - 90° | 45° - 60° 90° - 120° | |
| 6 | 1.12 | 1.6 | 1.12 | 2.36 | 1.7 | 1.8 |
| 7 | 1.5 | 2.12 | 1.5 | 3.15 | 2.24 | 2.5 |
| 8 | 2.0 | 2.8 | 2.0 | 4.25 | 3.0 | 3.15 |
| 10 | 3.15 | 4.25 | 3.15 | 6.7 | 4.75 | 5.0 |
| 13 | 5.3 | 7.5 | 5.3 | 11.2 | 8.0 | 8.5 |
| 16 | 8.0 | 11.2 | 8.0 | 17.0 | 11.5 | 12.5 |
| 19 | 11.2 | 16.0 | 11.2 | 23.6 | 17.0 | 18.0 |
| 20 | 12.5 | 17.0 | 12.5 | 26.5 | 19.0 | 20.0 |
| 22 | 15.0 | 21.2 | 15.0 | 31.5 | 22.4 | 23.6 |
| 26 | 21.2 | 30.0 | 21.2 | 45.0 | 31.5 | 33.5 |
| 32 | 31.5 | 45.0 | 31.5 | 67.0 | 47.5 | 50.0 |

**Safety factor 4:1 above limits are valid for standard use and equally loaded slings. Properly use and maintainance of your YOKE chain slings will give long life and enable you to carry out your lifting operations efficiently and safely.

Warning: Never exceed a vertical sling angle of 60°

SAFE USE

- Never load in excess of the rated capacity for the application.
- Keep a record of all slings in use.
- User should remove all twists from a chain leg before lifting and, should never knot a chain.
- Always use YOKE shortening hook or clutch when chain slings should be shortened.
- Always inspect to insure that chain is free from damage or wear before use.
- Always inspect all sling components prior to each use.
- Ensure that chain is protected from any sharp corners on the load.
- Ensure that the master link articulates freely on the hook of the crane or other lifting appliance.
- Never tip load hooks. The load should always be supported correctly in the bowl of the hook.
- Always use the correct size sling for the load, allowing for the included angle and the possibility of unequal loading.
- Personnel must keep all body parts from between the sling and the load, and from between the sling and the crane/hoist hook. Persons shall never ride the chain sling/rope sling or web sling or the load during lifting or while suspended. Persons must stand clear of all loads while lifting or while suspended. During lifting, with or without the load, personnel must be alert for possible snagging of the load or the chain sling.

MAINTENANCE

- A thorough examination should be carried out by a competent person at intervals at least every year or more frequently according to statutory regulations, type of use and past records.
- Chains with bent links or with cracks or gouges in the link should be replaced , as should deformed components such as bent master links , deformed hooks and any fittings showing signs of damage.
- Chain and components wear should never exceed 10%of the original dimensions.
- Once a chain sling has been overloaded it must be taken out of service.
- Store chain slings on a properly designed rack. They should not be left lying on the floor where they may suffer mechanical or corrosion damage or may be lost.

LIMITATION ON USE

- YOKE alloy chain or chain slings should not be used in acid or caustic solutions nor in heavily acidic or caustic laden atmospheres. The high tensile strength of the heat treated alloy material in alloy steel chains and components is susceptible to hydrogen embrittlement when exposed to acids.
- YOKE slings must not be heat-treated, galvanized, plated, coated or subject to any process involving heating or pickling. Each of these processes can have dangerous effects and will invalidate the manufacturer certificate.
- YOKE slings may be used at temperatures between -40°C to 200°C with no reduction in the working load limit . The use of YOKE chain slings within the permissible temperature range in the table below does not require any permanent reduction in working load limit when the chain sling is returned to normal temperatures. A sling accidentally exposed to temperatures in excess of the maximum permissible should be withdrawn form service immediately and returned to the distributor for thorough examination.

- When using YOKE slings in exceptionally hazardous conditions, the degree of hazard should be assessed by a competent person and the Working Load Limit adjusted accordingly. Examples are lifting of potentially dangerous loads such as molten metals, corrosive materials or fissile material and including certain offshore activities.

| Sling temperature (F) | Sling temperature (C) | Reduction in Working Load Limit |
|-----------------------|-----------------------|---------------------------------|
| -40°F to 400°F | -40°C to 200°C | None |
| 400°F to 550°F | 200°C to 300°C | 10% |
| 550°F to 750°F | 300°C to 400°C | 25% |
| Above 750°F | Above 400°C | Do not use. |

Oblong Master Link.

Connected to Chain with "YA" connecting link.

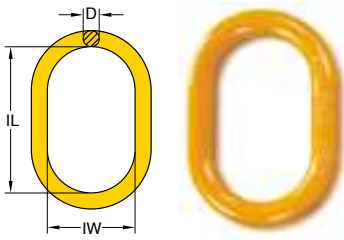

Extra width inside allows better works on large crane hooks.



Type Approval



| Item No. | WLL β 0-45° tonnes* | For Grade 80 Chain(mm) | | Dimensions (mm) | | | N.W. kg |
|--------------|---------------------------|------------------------------|--------|-----------------|-----|-----|------------|
| | | 1 Leg | 2 Leg | D | IL | IW | |
| 8-003-06 ※ | 1.25 | 6 | -- | 11 | 100 | 60 | 0.2 |
| 8-003-0806 ※ | 2.5 | 7, 8 | 6 | 14 | 120 | 70 | 0.4 |
| 8-003-1008 ※ | 4.0 | 10 | 7, 8 | 17 | 140 | 80 | 0.7 |
| 8-003-13 ※ | 5.4 | 13 | -- | 19 | 150 | 90 | 1.1 |
| 8-003-1310 ※ | 7.5 | 13 | 10 | 22 | 160 | 95 | 1.5 |
| 8-003-16 ※ | 10.0 | 16 | -- | 25 | 190 | 110 | 2.2 |
| 8-003-1613 ※ | 10.0 | 16 | 13 | 28 | 180 | 105 | 2.8 |
| 8-003-19 ※ | 12.0 | 19, 20 | -- | 30 | 200 | 120 | 3.8 |
| 8-003-2216 ※ | 17.0 | 22 | 16 | 34 | 240 | 140 | 5.5 |
| 8-003-26 ※ | 25.0 | 26 | -- | 38 | 250 | 150 | 7.0 |
| 8-003-2619 ※ | 28.0 | 26 | 19, 20 | 40 | 250 | 150 | 8.0 |
| 8-003-3222 ※ | 37.0 | 32 | 22 | 45 | 300 | 180 | 12.7 |

※ Forged Oblong Master Links.

Design factor 4:1 proof tested and certified Tested acc. to EN 1677

Oblong Master Link with Flat.

Connected to Chain with "YO" Omega Link.

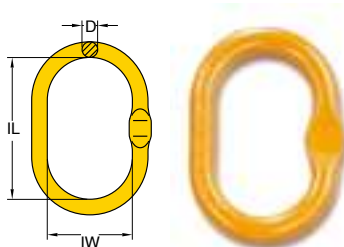

Type Approval



| Item No. | WLL β 0-45° tonnes* | For Grade 80 Chain(mm) | | Dimensions (mm) | | | N.W. kg |
|---------------|---------------------------|------------------------------|--------|-----------------|-----|-----|------------|
| | | 1 Leg | 2 Leg | D | IL | IW | |
| 8-003F-06 ※ | 1.25 | 6 | -- | 11 | 100 | 60 | 0.2 |
| 8-003F-0806 ※ | 2.5 | 7, 8 | 6 | 14 | 120 | 70 | 0.4 |
| 8-003F-1008 ※ | 4.0 | 10 | 7, 8 | 17 | 140 | 80 | 0.7 |
| 8-003F-1310 ※ | 7.5 | 13 | 10 | 22 | 160 | 95 | 1.5 |
| 8-003F-1613 ※ | 10.0 | 16 | 13 | 28 | 184 | 105 | 2.8 |
| 8-003F-2216 ※ | 17.0 | 20 | 16 | 34 | 245 | 140 | 5.3 |
| 8-003F-2619 ※ | 25.0 | -- | 19, 20 | 40 | 250 | 150 | 8.0 |

※ Forged Oblong Master Links.

★ Design factor 4:1 Proof tested and certified

WLL=Working Load Limit Tested acc. to EN 1677

Clevis Master Link.

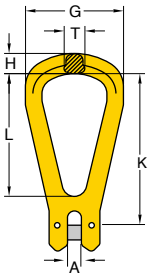

| Item No. | Working Load Limit tonnes* | For Grade 80 Chain mm | Dimensions (mm) | | | | | | N.W. kg |
|----------|-------------------------------|--------------------------|-----------------|-----|----|-----|-----|----|------------|
| | | | A | G | H | K | L | T | |
| 8-059-07 | 2.0 | 7, 8 | 10 | 65 | 15 | 103 | 83 | 19 | 0.4 |
| 8-059-10 | 3.15 | 10 | 11 | 96 | 19 | 133 | 108 | 19 | 0.8 |
| 8-059-13 | 5.3 | 13 | 15 | 108 | 22 | 168 | 136 | 25 | 1.5 |
| 8-059-16 | 8.0 | 16 | 18 | 124 | 26 | 203 | 165 | 27 | 2.4 |

★ Design factor 4:1 proof tested and certified
Tested acc. to EN 1677

Connecting Link

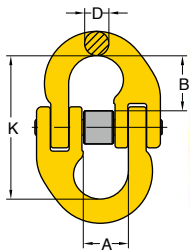

| Item No. | Working Load Limit tonnes* | For Grade 80 Chain mm | Dimensions (mm) | | | | N.W. kg |
|----------|-------------------------------|--------------------------|-----------------|----|----|-----|------------|
| | | | A | B | D | K | |
| 8-015-06 | 1.12 | 6 | 15 | 17 | 7 | 45 | 0.08 |
| 8-015-07 | 2.0 | 7, 8 | 18 | 22 | 9 | 58 | 0.2 |
| 8-015-10 | 3.15 | 10 | 26 | 27 | 11 | 69 | 0.3 |
| 8-015-13 | 5.3 | 13 | 30 | 37 | 15 | 91 | 0.7 |
| 8-015-16 | 8.0 | 16 | 36 | 39 | 19 | 101 | 1.1 |
| 8-015-20 | 12.5 | 18, 20 | 42 | 46 | 22 | 122 | 1.9 |
| 8-015-22 | 15.0 | 22 | 49 | 59 | 24 | 152 | 3.0 |
| 8-015-26 | 21.2 | 26 | 55 | 63 | 30 | 164 | 5.0 |
| 8-015-32 | 31.5 | 32 | 69 | 79 | 36 | 203 | 9.0 |



Type Approval

★ Design factor 4:1 proof tested and certified
Tested acc. to EN 1677

Connecting Link

Dacromet® Surface Finish.**



special pin and sleeve designed for more often re-use purpose.

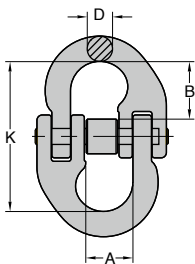

| Item No. | Working Load Limit tonnes* | For Grade 80 Chain mm | Dimensions (mm) | | | | N.W. kg |
|-----------|-------------------------------|--------------------------|-----------------|----|----|-----|------------|
| | | | A | B | D | K | |
| 8-M015-06 | 1.12 | 6 | 15 | 17 | 7 | 45 | 0.16 |
| 8-M015-07 | 2.0 | 7, 8 | 18 | 24 | 9 | 58 | 0.16 |
| 8-M015-10 | 3.15 | 10 | 26 | 28 | 11 | 69 | 0.3 |
| 8-M015-13 | 5.3 | 13 | 30 | 38 | 15 | 91 | 0.7 |
| 8-M015-16 | 8.0 | 16 | 36 | 41 | 19 | 101 | 1.2 |
| 8-M015-20 | 12.5 | 18, 20 | 42 | 50 | 22 | 122 | 1.9 |
| 8-M015-22 | 15.0 | 22 | 49 | 63 | 24 | 152 | 3.0 |
| 8-M015-26 | 21.2 | 26 | 55 | 66 | 30 | 164 | 4.6 |
| 8-M015-32 | 31.5 | 32 | 69 | 85 | 36 | 203 | 8.5 |



Type Approval



★ Design factor 4:1 proof tested and certified
Tested acc. to EN 1677

Omega Link.

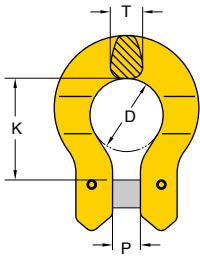

| Item No. | Working Load Limit tonnes* | For Grade 80 Chain mm | Dimensions (mm) | | | | N.W. kg |
|----------|-------------------------------|--------------------------|-----------------|----|----|----|------------|
| | | | D | K | P | T | |
| 8-018-06 | 1.12 | 6 | 22 | 29 | 7 | 9 | 0.1 |
| 8-018-07 | 2.0 | 7, 8 | 27 | 36 | 9 | 11 | 0.2 |
| 8-018-10 | 3.15 | 10 | 32 | 44 | 12 | 15 | 0.4 |
| 8-018-13 | 5.3 | 13 | 42 | 55 | 16 | 17 | 0.8 |
| 8-018-16 | 8.0 | 16 | 50 | 69 | 18 | 22 | 1.6 |
| 8-018-20 | 12.5 | 18, 20 | 58 | 81 | 22 | 28 | 2.1 |

★ Design factor 4:1 proof tested and certified
Tested acc. to EN 1677



Swivel Self Locking Hook.

with Brass Bushing

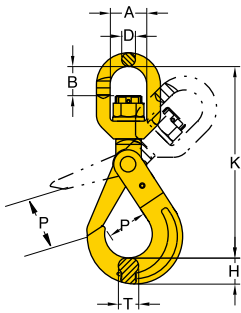

| Item No. | Working Load Limit tonnes* | For Grade 80 Chain mm | Dimensions (mm) | | | | | | | N.W. kg |
|----------|-------------------------------|--------------------------|-----------------|-----|----|----|-----|----|----|------------|
| | | | A | B | D | H | K | P | T | |
| 8-027-06 | 1.12 | 6 | 32 | 25 | 12 | 19 | 149 | 28 | 15 | 0.7 |
| 8-027-07 | 2.0 | 7, 8 | 36 | 30 | 14 | 24 | 186 | 34 | 20 | 1.2 |
| 8-027-10 | 3.15 | 10 | 41 | 38 | 16 | 30 | 218 | 44 | 26 | 2.0 |
| 8-027-13 | 5.3 | 13 | 46 | 48 | 22 | 39 | 276 | 51 | 30 | 4.1 |
| 8-027-16 | 8.0 | 16 | 61 | 56 | 24 | 49 | 329 | 61 | 36 | 7.2 |
| 8-027-20 | 12.5 | 18, 20 | 74 | 86 | 26 | 62 | 403 | 91 | 48 | 11.5 |
| 8-027-22 | 15.0 | 22 | 97 | 98 | 33 | 63 | 457 | 80 | 49 | 18.6 |
| 8-027-26 | 21.2 | 26 | 123 | 120 | 26 | 69 | 535 | 99 | 56 | 31.9 |

★ Design factor 4:1 proof tested and certified
Tested acc. to EN 1677

⚠ **WARNING INFORMATION:** This hook is a positioning device and is not intended to rotate under load. For swivel hooks designed to rotate under load, see p.129 8-027N .



Type Approval

Swivel Self Locking Hook.

with Ball Bearing, which performs full swivel underload

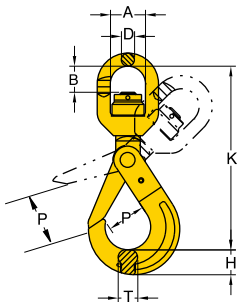

| Item No. | Working Load Limit tonnes* | For Grade 80 Chain mm | Dimensions (mm) | | | | | | | N.W. kg |
|-----------|-------------------------------|--------------------------|-----------------|-----|----|----|-----|----|----|------------|
| | | | A | B | D | H | K | P | T | |
| 8-027N-06 | 1.12 | 6 | 32 | 23 | 12 | 19 | 149 | 28 | 15 | 0.7 |
| 8-027N-07 | 2.0 | 7, 8 | 36 | 29 | 14 | 24 | 186 | 34 | 20 | 1.2 |
| 8-027N-10 | 3.15 | 10 | 41 | 34 | 16 | 30 | 218 | 44 | 26 | 2.0 |
| 8-027N-13 | 5.3 | 13 | 46 | 44 | 22 | 39 | 276 | 51 | 30 | 4.2 |
| 8-027N-16 | 8.0 | 16 | 61 | 51 | 24 | 49 | 329 | 61 | 36 | 7.3 |
| 8-027N-20 | 12.5 | 18, 20 | 74 | 82 | 26 | 62 | 403 | 91 | 48 | 11.7 |
| 8-027N-22 | 15.0 | 22 | 97 | 96 | 33 | 63 | 457 | 80 | 49 | 18.0 |
| 8-027N-26 | 21.2 | 26 | 123 | 116 | 26 | 69 | 535 | 99 | 56 | 32.0 |

★ Design factor 4:1 proof tested and certified
Tested acc. to EN 1677



Type Approval

How to use YOKE Self Locking Hook?



Eye Self Locking Hook.

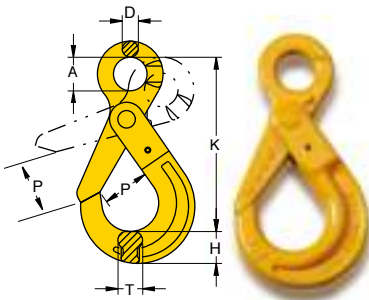

| Item No. | Working Load Limit tonnes* | For Grade 80 Chain mm | Dimensions (mm) | | | | | | N.W. kg |
|----------|-------------------------------|--------------------------|-----------------|----|----|-----|-----|----|------------|
| | | | A | D | H | K | P | T | |
| 8-025-06 | 1.12 | 6 | 21 | 10 | 19 | 110 | 28 | 15 | 0.5 |
| 8-025-07 | 2.0 | 7,8 | 25 | 11 | 24 | 136 | 34 | 20 | 0.8 |
| 8-025-10 | 3.15 | 10 | 33 | 13 | 30 | 167 | 44 | 26 | 1.4 |
| 8-025-13 | 5.3 | 13 | 40 | 16 | 39 | 207 | 51 | 30 | 3.0 |
| 8-025-16 | 8.0 | 16 | 50 | 21 | 49 | 252 | 61 | 36 | 5.8 |
| 8-025-20 | 12.5 | 18, 20 | 62 | 23 | 62 | 281 | 91 | 48 | 8.5 |
| 8-025-22 | 15.0 | 22 | 70 | 24 | 63 | 319 | 80 | 49 | 12.5 |
| 8-025-26 | 21.2 | 26 | 80 | 25 | 69 | 343 | 99 | 56 | 14.0 |
| 8-025-28 | 25.0 | 28 | 92 | 28 | 81 | 405 | 123 | 63 | 26.0 |

★ Design factor 4:1 proof tested and certified
Tested acc. to EN 1677

Clevis Self Locking Hook.

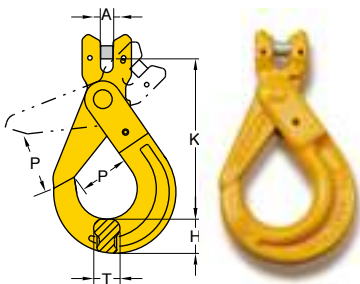

Type Approval

| Item No. | Working Load Limit tonnes* | For Grade 80 Chain mm | Dimensions (mm) | | | | | N.W. kg |
|----------|-------------------------------|--------------------------|-----------------|----|-----|----|----|------------|
| | | | A | H | K | P | T | |
| 8-026-06 | 1.12 | 6 | 7 | 19 | 93 | 28 | 15 | 0.5 |
| 8-026-07 | 2.0 | 7, 8 | 9 | 24 | 119 | 34 | 20 | 0.8 |
| 8-026-10 | 3.15 | 10 | 12 | 30 | 143 | 44 | 26 | 1.4 |
| 8-026-13 | 5.3 | 13 | 15 | 39 | 179 | 51 | 30 | 2.9 |
| 8-026-16 | 8.0 | 16 | 18 | 49 | 212 | 61 | 36 | 5.6 |
| 8-026-20 | 12.5 | 18, 20 | 21 | 62 | 243 | 91 | 48 | 9.0 |
| 8-026-22 | 15.0 | 22 | 24 | 63 | 273 | 80 | 49 | 13.0 |

★ Design factor 4:1 proof tested and certified
Tested acc. to EN 1677

Eye Sling Hook.

with Latch

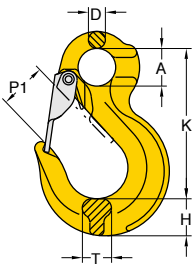

Type Approval

| Item No. | Working Load Limit tonnes* | For Grade 80 Chain mm | Dimensions (mm) | | | | | | N.W. kg |
|------------|-------------------------------|--------------------------|-----------------|----|----|-----|-----|----|------------|
| | | | A | D | H | K | P1 | T | |
| 8-044/S-06 | 1.12 | 6 | 20 | 10 | 19 | 80 | 23 | 17 | 0.3 |
| 8-044/S-07 | 2.0 | 7, 8 | 25 | 12 | 22 | 98 | 28 | 20 | 0.5 |
| 8-044/S-10 | 3.15 | 10 | 32 | 15 | 30 | 121 | 36 | 23 | 1.0 |
| 8-044/S-13 | 5.3 | 13 | 40 | 18 | 38 | 152 | 40 | 28 | 1.7 |
| 8-044/S-16 | 8.0 | 16 | 50 | 22 | 45 | 185 | 44 | 32 | 3.2 |
| 8-044/S-20 | 12.5 | 18, 20 | 62 | 27 | 49 | 225 | 45 | 46 | 5.5 |
| 8-044/S-22 | 15.0 | 22 | 51 | 31 | 62 | 244 | 73 | 52 | 9.0 |
| 8-044/S-26 | 21.2 | 26 | 64 | 35 | 77 | 285 | 77 | 61 | 13.5 |
| 8-044/S-32 | 31.5 | 32 | 89 | 40 | 80 | 352 | 114 | 65 | 20.0 |

★ Design factor 4:1 proof tested and certified
Tested acc. to EN 1677

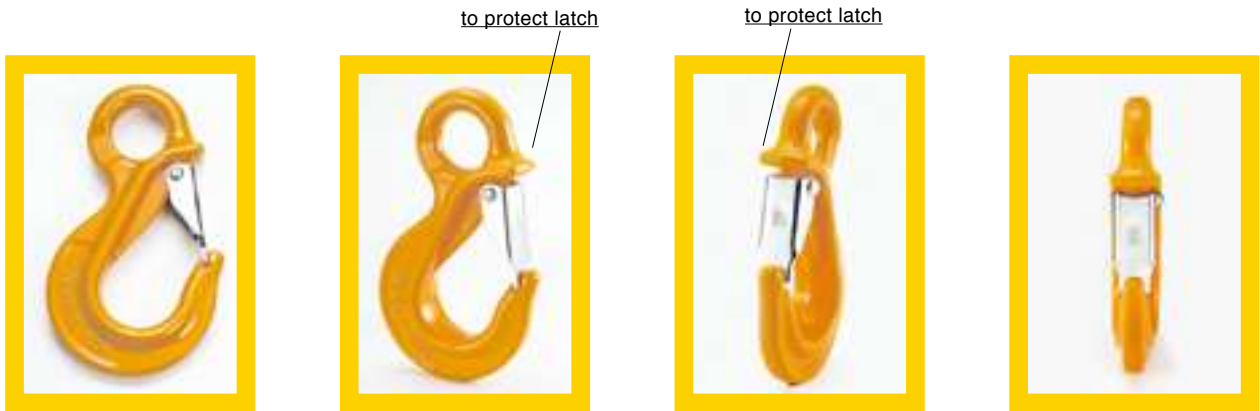

Eye Foundry Hook.

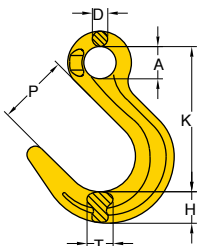

Type Approval

| Item No. | Working Load Limit tonnes* | For Grade 80 Chain mm | Dimensions (mm) | | | | | | N.W. kg |
|----------|-------------------------------|--------------------------|-----------------|----|----|-----|-----|----|------------|
| | | | A | D | H | K | P | T | |
| 8-047-07 | 2.0 | 7, 8 | 24 | 12 | 27 | 122 | 61 | 19 | 0.7 |
| 8-047-10 | 3.15 | 10 | 32 | 15 | 32 | 150 | 74 | 23 | 1.3 |
| 8-047-13 | 5.3 | 13 | 40 | 19 | 39 | 180 | 88 | 32 | 2.3 |
| 8-047-16 | 8.0 | 16 | 50 | 24 | 46 | 215 | 98 | 41 | 4.1 |
| 8-047-20 | 12.5 | 18,20 | 60 | 26 | 59 | 248 | 112 | 58 | 9.3 |

★ Design factor 4:1 proof tested and certified
Tested acc. to EN 1677

Clevis Sling Hook.

with Latch

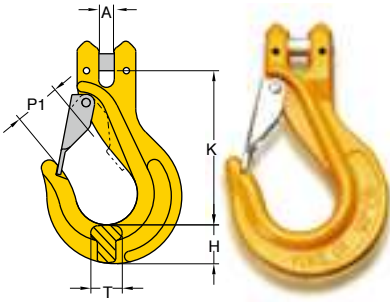

| Item No. | Working Load Limit tonnes* | For Grade 80 Chain mm | Dimensions (mm) | | | | | N.W. kg |
|------------|-------------------------------|--------------------------|-----------------|----|-----|----|----|------------|
| | | | A | H | K | P1 | T | |
| 8-043/S-06 | 1.12 | 6 | 7 | 18 | 79 | 23 | 15 | 0.3 |
| 8-043/S-07 | 2.0 | 7, 8 | 9 | 22 | 98 | 27 | 18 | 0.6 |
| 8-043/S-10 | 3.15 | 10 | 12 | 29 | 121 | 34 | 23 | 1.2 |
| 8-043/S-13 | 5.3 | 13 | 15 | 37 | 147 | 44 | 30 | 2.3 |
| 8-043/S-16 | 8.0 | 16 | 18 | 42 | 166 | 48 | 39 | 3.7 |
| 8-043/S-20 | 12.5 | 18, 20 | 21 | 50 | 200 | 56 | 47 | 6.5 |



Type Approval

★ Design factor 4:1 proof tested and certified
Tested acc. to EN 1677

Clevis Shackle.

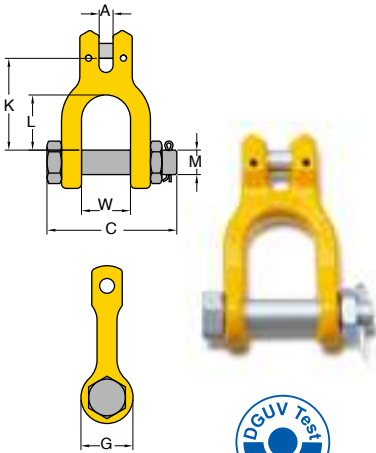

| Item No. | Working Load Limit tonnes* | For Grade 80 Chain mm | Dimensions (mm) | | | | | | | N.W. kg |
|----------|-------------------------------|--------------------------|-----------------|-----|----|-----|----|----|----|------------|
| | | | A | C | G | K | L | M | W | |
| 8-066-07 | 2.0 | 7, 8 | 9 | 79 | 34 | 59 | 35 | 16 | 32 | 0.4 |
| 8-066-10 | 3.15 | 10 | 12 | 93 | 40 | 78 | 48 | 20 | 34 | 0.8 |
| 8-066-13 | 5.3 | 13 | 15 | 118 | 44 | 98 | 64 | 22 | 50 | 1.4 |
| 8-066-16 | 8.0 | 16 | 18 | 141 | 55 | 112 | 68 | 28 | 60 | 2.4 |



Type Approval

★ Design factor 4:1 proof tested and certified
Tested acc. to EN 1677

Clevis C Hook.

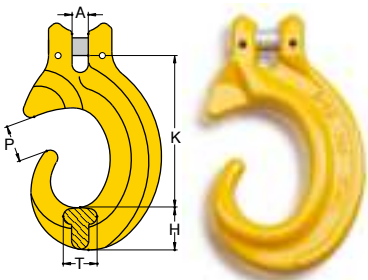

| Item No. | Working Load Limit tonnes* | For Grade 80 Chain mm | Dimensions (mm) | | | | | N.W. kg |
|----------|-------------------------------|--------------------------|-----------------|----|-----|----|----|------------|
| | | | A | H | K | P | T | |
| 8-097-07 | 2.0 | 7, 8 | 9 | 22 | 80 | 19 | 18 | 0.5 |
| 8-097-10 | 3.15 | 10 | 12 | 26 | 103 | 26 | 24 | 0.9 |
| 8-097-13 | 5.3 | 13 | 15 | 34 | 135 | 34 | 32 | 2.1 |
| 8-097-16 | 8.0 | 16 | 18 | 45 | 160 | 38 | 37 | 3.8 |



Type Approval

★ Design factor 4:1 proof tested and certified
Tested acc. to EN 1677

Eye Swivel Hook.

with Ball Bearing, which performs full swivel under load

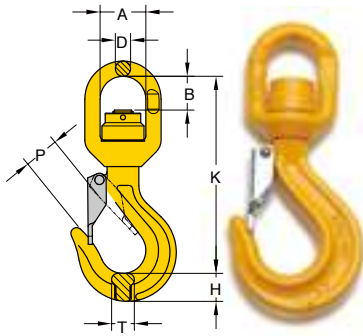

| Item No. | Working Load Limit tonnes* | For Grade 80 Chain mm | Dimensions (mm) | | | | | | | N.W. kg |
|-----------|-------------------------------|--------------------------|-----------------|----|----|----|-----|----|----|------------|
| | | | A | B | D | H | K | P | T | |
| 8-049N-06 | 1.12 | 6 | 32 | 23 | 11 | 19 | 136 | 24 | 16 | 0.6 |
| 8-049N-07 | 2.0 | 7, 8 | 36 | 27 | 12 | 22 | 155 | 26 | 18 | 0.9 |
| 8-049N-10 | 3.15 | 10 | 41 | 37 | 16 | 29 | 189 | 36 | 23 | 1.6 |
| 8-049N-13 | 5.3 | 13 | 46 | 40 | 21 | 35 | 233 | 42 | 28 | 3.4 |
| 8-049N-16 | 8.0 | 16 | 61 | 50 | 22 | 44 | 280 | 50 | 35 | 5.1 |
| 8-049N-20 | 12.5 | 18, 20 | 74 | 82 | 25 | 65 | 356 | 56 | 49 | 9.5 |

★ Design factor 4:1 proof tested and certified
Tested acc. to EN 1677

Clevis Traveling Clutch.

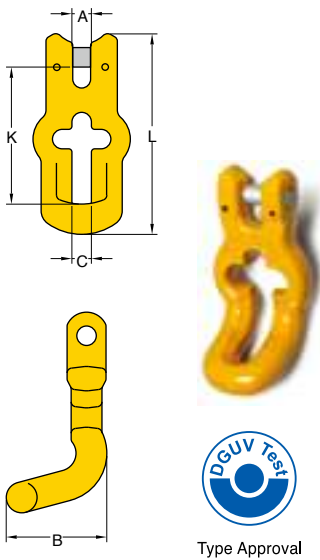

| Item No. | Working Load Limit tonnes* | For Grade 80 Chain mm | Dimensions (mm) | | | | | N.W. kg |
|----------|-------------------------------|--------------------------|-----------------|----|----|----|-----|------------|
| | | | A | B | C | K | L | |
| 8-064-06 | 1.12 | 5, 6 | 7 | 31 | 8 | 64 | 86 | 0.2 |
| 8-064-07 | 2.0 | 7, 8 | 9 | 44 | 10 | 73 | 104 | 0.4 |
| 8-064-10 | 3.15 | 10 | 11 | 61 | 13 | 82 | 121 | 0.7 |

★ Design factor 4:1 proof tested and certified.
Tested acc. to EN 1677

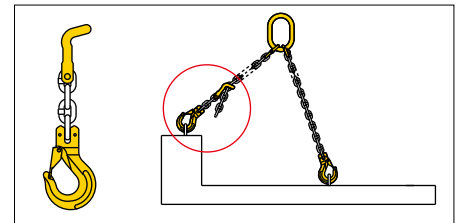

Item No.8-Tag-06 Sling Tag, Steel.



Eye Grab Hook.

Not for use with Omega Link Item. 8-018
No reduction of working load limit, thanks to supporting wings which prevent chain link deformation.

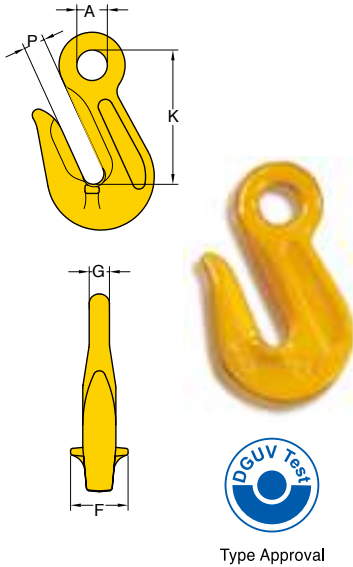

| Item No. | Working Load Limit tonnes* | For Grade 80 Chain mm | Dimensions (mm) | | | | | N.W. kg |
|----------|-------------------------------|--------------------------|-----------------|-----|----|-----|----|------------|
| | | | A | F | G | K | P | |
| 8-041-06 | 1.12 | 6 | 13 | 26 | 8 | 51 | 8 | 0.2 |
| 8-041-07 | 2.0 | 7, 8 | 15 | 30 | 9 | 62 | 10 | 0.3 |
| 8-041-10 | 3.15 | 10 | 20 | 40 | 13 | 82 | 13 | 0.6 |
| 8-041-13 | 5.3 | 13 | 26 | 52 | 16 | 107 | 16 | 1.4 |
| 8-041-16 | 8.0 | 16 | 30 | 70 | 20 | 132 | 22 | 2.3 |
| 8-041-20 | 12.5 | 18, 20 | 38 | 73 | 24 | 147 | 24 | 3.9 |
| 8-041-22 | 15.0 | 22 | 42 | 86 | 26 | 166 | 26 | 4.7 |
| 8-041-26 | 21.2 | 26 | 50 | 110 | 32 | 207 | 30 | 9.9 |
| 8-041-32 | 31.5 | 32 | 61 | 127 | 41 | 269 | 37 | 21.4 |

★ Design factor 4:1 proof tested and certified.
Tested acc. to EN 1677

Clevis Grab Hook.

Not for use with Omega Link Item. 8-018
No reduction of working load limit, thanks to supporting wings which prevent chain link deformation.

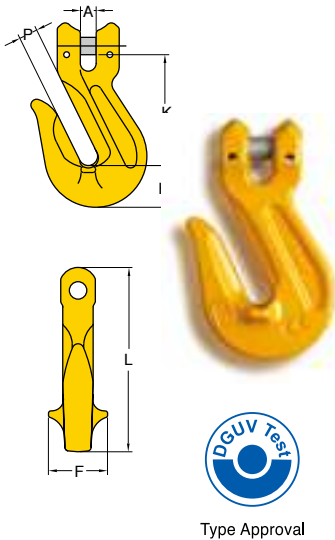

| Item No. | Working Load Limit tonnes* | For Grade 80 Chain mm | Dimensions (mm) | | | | | | N.W. kg |
|----------|-------------------------------|--------------------------|-----------------|----|----|-----|-----|----|------------|
| | | | A | F | H | K | L | P | |
| 8-042-06 | 1.12 | 6 | 7 | 25 | 17 | 47 | 79 | 8 | 0.2 |
| 8-042-07 | 2.0 | 7, 8 | 9 | 30 | 21 | 54 | 93 | 10 | 0.3 |
| 8-042-10 | 3.15 | 10 | 12 | 41 | 29 | 77 | 128 | 13 | 0.8 |
| 8-042-13 | 5.3 | 13 | 15 | 52 | 37 | 99 | 165 | 16 | 1.6 |
| 8-042-16 | 8.0 | 16 | 18 | 57 | 45 | 114 | 195 | 20 | 2.8 |
| 8-042-20 | 12.5 | 18, 20 | 21 | 73 | 52 | 130 | 222 | 23 | 4.8 |

★ Design factor 4:1 proof tested and certified.
Tested acc. to EN 1677

Clevis Clutch - Locking Type.

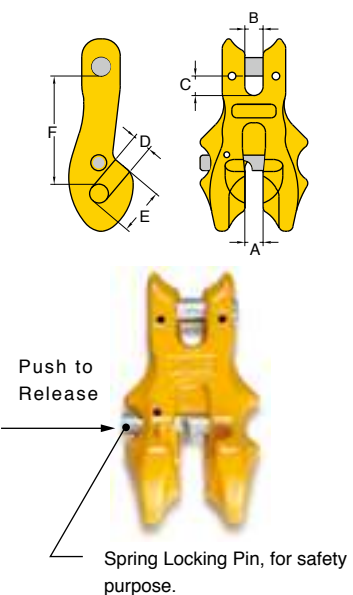

| Item No. | Working Load Limit tonnes* | For Grade 80 Chain mm | Dimensions (mm) | | | | | | N.W. kg |
|----------|-------------------------------|--------------------------|-----------------|----|----|----|----|-----|------------|
| | | | A | B | C | D | E | F | |
| 8-061-06 | 1.12 | 6 | 7 | 7 | 10 | 7 | 18 | 50 | 0.3 |
| 8-061-07 | 2.0 | 7, 8 | 10 | 10 | 10 | 10 | 24 | 56 | 0.5 |
| 8-061-10 | 3.15 | 10 | 12 | 12 | 12 | 12 | 28 | 66 | 0.9 |
| 8-061-13 | 5.3 | 13 | 15 | 15 | 16 | 16 | 39 | 88 | 2.2 |
| 8-061-16 | 8.0 | 16 | 21 | 18 | 18 | 19 | 48 | 103 | 3.7 |
| 8-061-20 | 12.5 | 18, 20 | 23 | 22 | 23 | 23 | 53 | 129 | 5.8 |

★ Design factor 4:1 proof tested and certified.
Tested acc. to EN 1677

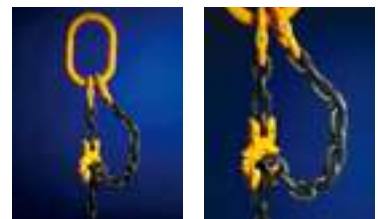



Eye Container Hook.

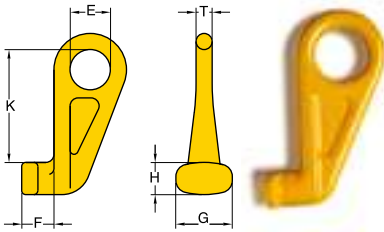

| Item No. | Dsc. | Working Load Limit tonnes* | Dimensions (mm) | | | | | | | N.W. kg |
|------------|-----------|-------------------------------|-----------------|----|----|----|-----|----|-----|------------|
| | | | E | F | G | H | K | T | | |
| 8-067-STR | Straight | 12.5 | 70 | 45 | 75 | 48 | 192 | 25 | 3.9 | |
| 8-067-45LT | Left 45° | 12.5 | 70 | 45 | 75 | 48 | 192 | 25 | 3.9 | |
| 8-067-45RH | Right 45° | 12.5 | 70 | 45 | 75 | 48 | 192 | 25 | 3.9 | |

8-067-45LT

8-067-45RH

8-067-STR

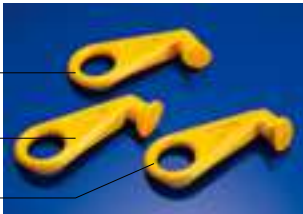

Type Approval



★ Design factor 4:1 proof tested and certified.

Shortening Clutch

with Half Link

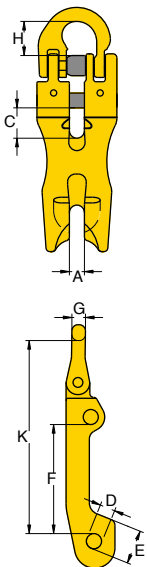

| Item No. | Working Load Limit tonnes* | For Grade 80 Chain mm | Dimensions (mm) | | | | | | | | N.W. kg |
|----------|-------------------------------|--------------------------|-----------------|----|----|----|-----|----|----|-----|------------|
| | | | A | C | D | E | F | H | G | K | |
| 8-078-07 | 2.0 | 7, 8 | 12 | 20 | 10 | 23 | 70 | 22 | 9 | 128 | 0.7 |
| 8-078-10 | 3.15 | 10 | 13 | 26 | 12 | 29 | 87 | 26 | 11 | 154 | 1.3 |
| 8-078-13 | 5.3 | 13 | 15 | 33 | 16 | 37 | 115 | 36 | 15 | 203 | 2.8 |
| 8-078-16 | 8.0 | 16 | 21 | 39 | 19 | 46 | 143 | 39 | 19 | 248 | 5.3 |

★ Design factor 4:1 proof tested and certified.
Tested acc. to EN 1677



Shackle Eye Swivel Hook, with brass bushing.

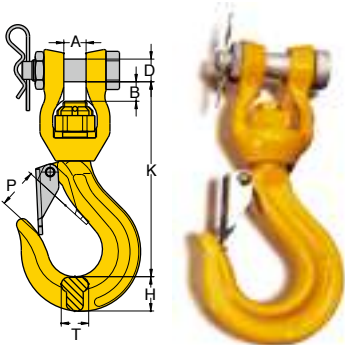

| Item No. | Working Load Limit tonnes* | For Grade 80 Chain mm | Dimensions (mm) | | | | | | | N.W. kg |
|----------|-------------------------------|--------------------------|-----------------|----|----|----|-----|----|----|------------|
| | | | A | B | D | H | K | P | T | |
| 8-048-16 | 8.0 | 16 | 28 | 28 | 28 | 45 | 225 | 54 | 35 | 6.0 |



Type Approval

★ Design factor 4:1 proof tested and certified.
Tested acc. to EN 1677

⚠ **WARNING INFORMATION:** This hook is a positioning device and is not intended to rotate under load.

Sliding Choke Hook.

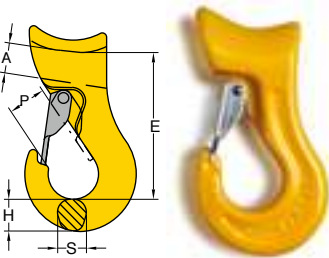

| Item No. | Working Load Limit tonnes* | For Wire Rope mm | Dimensions (mm) | | | | | N.W. kg |
|-------------|-------------------------------|---------------------|-----------------|----|----|----|----|------------|
| | | | A | E | H | P | S | |
| 8-074-09/13 | 1.5 | 9,13 | 16 | 87 | 24 | 18 | 18 | 0.6 |
| 8-074-14/16 | 2.2 | 14,16 | 21 | 98 | 29 | 20 | 22 | 0.9 |



Type Approval

★ Design factor 5 : 1

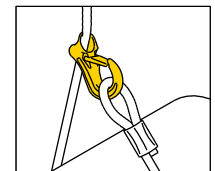

Twist Eye Choke Hook.

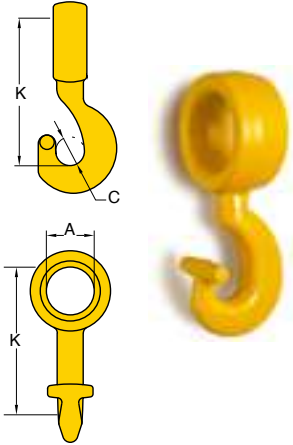

| Item No. | Working Load Limit tonnes* | For Grade 80 Chain mm | Dimensions (mm) | | | N.W. kg |
|----------|-------------------------------|--------------------------|-----------------|----|-----|------------|
| | | | A | C | K | |
| 8-063-07 | 2.0 | 7, 8 | 32 | 19 | 95 | 0.4 |
| 8-063-10 | 3.15 | 10 | 41 | 21 | 116 | 0.8 |
| 8-063-13 | 5.3 | 13 | 50 | 27 | 150 | 2.0 |
| 8-063-16 | 8.0 | 16 | 67 | 32 | 185 | 3.1 |

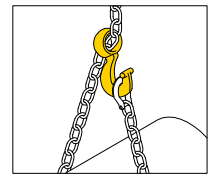

★ Design factor 4:1 proof tested and certified.
Tested acc. to EN 1677

Insulated Swivels

with 2 Half Links

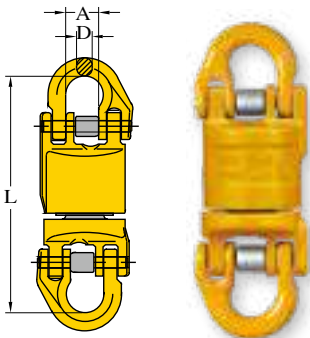

| Item No. | Working Load Limit tonnes* | For Grade 80 Chain mm | Dimensions (mm) | | | N.W. kg |
|----------|-------------------------------|--------------------------|-----------------|----|-----|------------|
| | | | A | D | L | |
| 8-123-07 | 2.0 | 7, 8 | 18 | 9 | 131 | 0.7 |
| 8-123-10 | 3.15 | 10 | 25 | 11 | 162 | 1.5 |
| 8-123-13 | 5.3 | 13 | 30 | 16 | 214 | 3.2 |
| 8-123-16 | 8.0 | 16 | 36 | 19 | 243 | 5.4 |
| 8-123-20 | 12.5 | 18, 20 | 42 | 22 | 285 | 9.0 |

1000 Volts Resistance

★ Design factor 4:1 proof tested and certified
Tested acc. to EN 1677



How to use YOKE Web Sling Connector?





YOKE Roundsling Self Locking Hook is designed in a way to solve your synthetic end-fitting problems.

The Roundsling Self Locking Hook presents following utmost benefits :

1. The Round Shape is designed to provide great protection to your synthetic roundsling on everyloading.
2. Offer complete range of hooks from 1 tonnes up to 21.2 tonnes.
3. Assembly is fast and easy with only a hammer required.
4. The hook with Self Locking function meets real safe and safer required.
5. Acquired  certificate approved by BG German company.



YOKE Insulation Solution

- YOKE Insulated Swivel is designed for winch protection in overhead crane during welding operations.
- Heavy hoisting with a strong but lightweight system.
- Individual swivels & components are proof load tested to a minimum of 2.5 times the working load limit.
- All Swivels are individually tested during manufacturing to assure 1000 Volts insulating property. Test certificate is packaged with each unit shipped.
- YOKE Insulated Swivels are designed with ball bearing which performs to fully swivel under Load.
- Acquired  certificate approved by Deutsche Gesetzliche Unfallversicherung (DGUV) .



1000 Volts Resistance

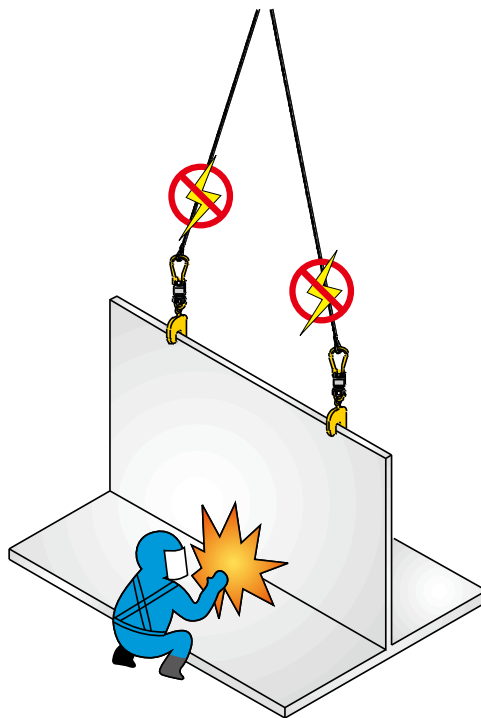

Coupling Self Locking Hook.

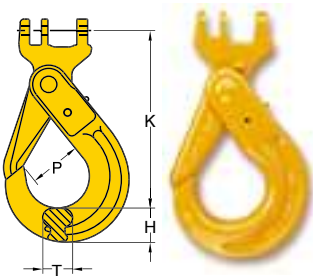

| Item No. | Working Load Limit tonnes* | For Grade 80 Chain mm | Dimensions (mm) | | | | N.W. kg |
|----------|-------------------------------|--------------------------|-----------------|-----|----|----|------------|
| | | | H | K | P | T | |
| 8-023-06 | 1.12 | 6 | 19 | 105 | 29 | 15 | 0.5 |
| 8-023-07 | 2.0 | 7, 8 | 24 | 136 | 34 | 20 | 0.8 |
| 8-023-10 | 3.15 | 10 | 30 | 154 | 44 | 26 | 1.3 |
| 8-023-13 | 5.3 | 13 | 39 | 202 | 55 | 30 | 2.8 |
| 8-023-16 | 8.0 | 16 | 49 | 242 | 60 | 36 | 5.7 |
| 8-023-20 | 12.5 | 18, 20 | 62 | 257 | 90 | 48 | 8.5 |
| 8-023-22 | 15.0 | 22 | 63 | 304 | 80 | 49 | 11.0 |
| 8-023-26 | 21.2 | 26 | 69 | 329 | 99 | 56 | 15.0 |

★ Design factor 4:1 proof tested and certified.

Tested acc. to EN 1677

YOKE's innovative, fine design with " **Coupling Pin** " system hook is able to solve any of your problems in Chain, Wire Rope and Synthetic Slings.

The hook :

1. Create safer lifting with the use of " Self Locking " system.
2. Assembly is fast and easy with only a hammer required.
3. Acquired certificate approved by BG German company.
4. **Patent** :Taiwan, China, France, Germany, Italy, Japan,USA, Switzerland.

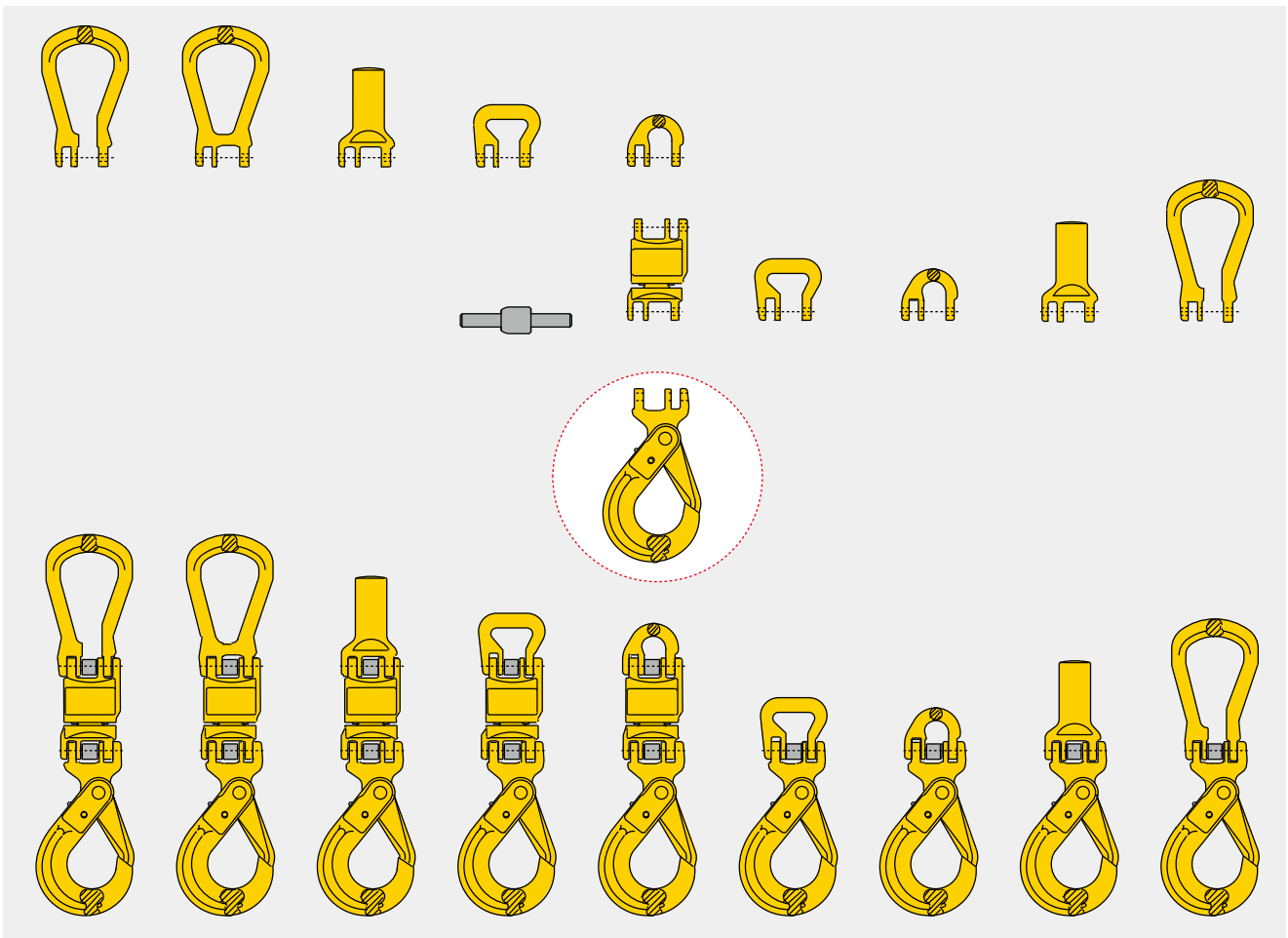

Insulated Blank Swivels.

with Ball Bearing

Individually tested to resist 1000 Volts insulated with Test Certificate.

Design for protection of overhead crane during welding operations on suspended loads.

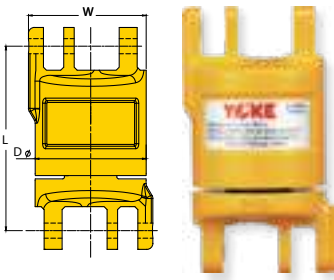

1000 Volts Resistance

| Item No. | Working Load Limit tonnes* | For Grade 80 Chain mm | Dimensions (mm) | | | N.W. kg |
|-----------|-------------------------------|--------------------------|-----------------|-----|------|------------|
| | | | L | D | W | |
| 8-088N-07 | 2.0 | 7, 8 | 75 | 48 | 50 | 0.7 |
| 8-088N-10 | 3.15 | 10 | 97 | 58 | 62 | 1.3 |
| 8-088N-13 | 5.3 | 13 | 123 | 74 | 78.5 | 2.7 |
| 8-088N-16 | 8.0 | 16 | 143 | 90 | 95 | 4.7 |
| 8-088N-20 | 12.5 | 18, 20 | 164 | 105 | 110 | 7.0 |

★ Design factor 4:1 proof tested and certified.
Tested acc. to EN 1677

Coupling Master Link.

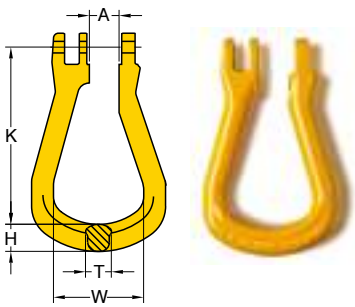

| Item No. | Working Load Limit tonnes* | For Grade 80 Chain mm | Dimensions (mm) | | | | | N.W. kg |
|----------|-------------------------------|--------------------------|-----------------|----|-----|----|-----|------------|
| | | | A | H | K | T | W | |
| 8-051-07 | 2.0 | 7, 8 | 15 | 15 | 100 | 15 | 50 | 0.3 |
| 8-051-10 | 3.15 | 10 | 19 | 19 | 127 | 19 | 66 | 0.6 |
| 8-051-13 | 5.3 | 13 | 25 | 22 | 145 | 23 | 72 | 1.0 |
| 8-051-16 | 8.0 | 16 | 30 | 26 | 174 | 25 | 80 | 1.6 |
| 8-051-20 | 12.5 | 18, 20 | 36 | 36 | 202 | 31 | 104 | 2.8 |

★ Design factor 4:1 proof tested and certified.
Tested acc. to EN 1677

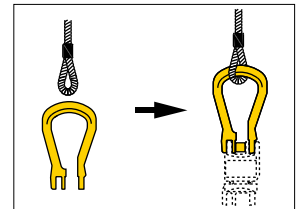

Closed Coupling Master Link.

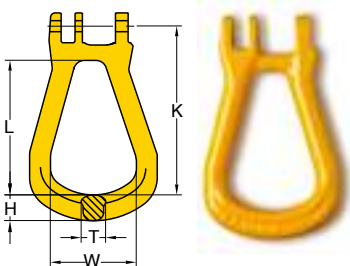

| Item No. | Working Load Limit tonnes* | For Grade 80 Chain mm | Dimensions (mm) | | | | | N.W. kg |
|----------|-------------------------------|--------------------------|-----------------|-----|-----|----|-----|------------|
| | | | H | K | L | T | W | |
| 8-052-07 | 2.0 | 7, 8 | 15 | 100 | 78 | 15 | 50 | 0.3 |
| 8-052-10 | 3.15 | 10 | 19 | 127 | 101 | 19 | 65 | 0.7 |
| 8-052-13 | 5.3 | 13 | 22 | 145 | 113 | 23 | 72 | 1.1 |
| 8-052-16 | 8.0 | 16 | 26 | 174 | 137 | 25 | 80 | 1.7 |
| 8-052-20 | 12.5 | 18, 20 | 36 | 202 | 165 | 31 | 104 | 3.0 |

★ Design factor 4:1 proof tested and certified.
Tested acc. to EN 1677



Type Approval

Half Coupling Link.

with Coupling Pin and Sleeve Locking

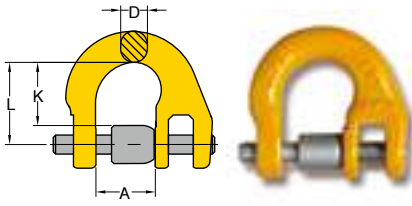

Type Approval

| Item No. | Working Load Limit tonnes* | For Grade 80 Chain mm | Dimensions (mm) | | | | N.W. kg |
|----------|-------------------------------|--------------------------|-----------------|----|----|-----|------------|
| | | | A | D | K | L | |
| 8-054-06 | 1.12 | 6 | 15 | 7 | 17 | 22 | 0.1 |
| 8-054-07 | 2.0 | 7, 8 | 18 | 9 | 22 | 28 | 0.1 |
| 8-054-10 | 3.15 | 10 | 25 | 11 | 26 | 34 | 0.2 |
| 8-054-13 | 5.3 | 13 | 30 | 16 | 35 | 45 | 0.4 |
| 8-054-16 | 8.0 | 16 | 36 | 19 | 38 | 50 | 0.6 |
| 8-054-20 | 12.5 | 18, 20 | 42 | 22 | 46 | 60 | 1.1 |
| 8-054-22 | 15.0 | 22 | 49 | 24 | 59 | 76 | 1.7 |
| 8-054-26 | 21.2 | 26 | 55 | 30 | 62 | 80 | 2.7 |
| 8-054-32 | 31.5 | 32 | 69 | 36 | 79 | 100 | 5.0 |

★ Design factor 4:1 proof tested and certified.

Tested acc. to EN 1677

Coupling Sling Hook.

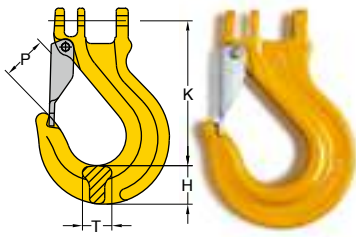

Type Approval

| Item No. | Working Load Limit tonnes* | For Grade 80 Chain mm | Dimensions (mm) | | | | N.W. kg |
|----------|-------------------------------|--------------------------|-----------------|-----|----|----|------------|
| | | | H | K | P | T | |
| 8-055-07 | 2.0 | 7, 8 | 23 | 93 | 30 | 19 | 0.4 |
| 8-055-10 | 3.15 | 10 | 31 | 115 | 36 | 23 | 0.9 |
| 8-055-13 | 5.3 | 13 | 36 | 141 | 42 | 28 | 1.8 |
| 8-055-16 | 8.0 | 16 | 45 | 166 | 47 | 32 | 3.0 |
| 8-055-20 | 12.5 | 18, 20 | 48 | 191 | 52 | 43 | 4.7 |

★ Design factor 4:1 proof tested and certified.

Tested acc. to EN 1677

Round Sling Coupling.

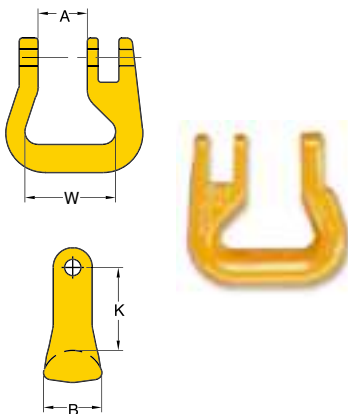

| Item No. | Working Load Limit tonnes* | For Grade 80 Chain mm | Dimensions (mm) | | | | N.W. kg |
|----------|-------------------------------|--------------------------|-----------------|----|-----|-----|------------|
| | | | A | B | K | W | |
| 8-053-06 | 1.12 | 6 | 15 | 22 | 33 | 38 | 0.2 |
| 8-053-07 | 2.0 | 7, 8 | 18 | 24 | 33 | 40 | 0.2 |
| 8-053-10 | 3.15 | 10 | 25 | 29 | 42 | 47 | 0.4 |
| 8-053-13 | 5.3 | 13 | 30 | 35 | 51 | 53 | 0.7 |
| 8-053-16 | 8.0 | 16 | 36 | 44 | 63 | 67 | 1.3 |
| 8-053-20 | 12.5 | 18, 20 | 42 | 52 | 71 | 80 | 2.1 |
| 8-053-22 | 15.0 | 22 | 49 | 72 | 112 | 125 | 5.7 |
| 8-053-26 | 21.2 | 26 | 55 | 84 | 130 | 150 | 9.0 |
| 8-053-32 | 31.5 | 32 | 69 | 85 | 165 | 190 | 14.0 |

★ Design factor 4:1 proof tested and certified.



YOKE

DATM
Offshore Lifting

*Safety is our first priority*TM

DNV 2.7-1 TYPE APPROVAL

Offshore Container Lifting Operation



DATM

Offshore Lifting

Offshore Container Lifting Operation.

Quality Management System:



Industrial Membership:



The Features of YOKE DA™ Offshore Container Lifting Series

YOKE DA™ Series are manufactured to meet the requirements of DNV 2.7-1 for offshore container lifting to fulfill the need for the critical requirements of charpy impact, strength and ductility.

Lower Temperature Demand

YOKE DA™ Series are designed to withstand impacts in extreme environments down to maximum -40° C.

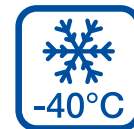

Higher Safety Factors

YOKE DA™ Shackles have a design factor of 6 for Grade 6 Shackles and a design factor of 8 for Grade 8 shackles, and YOKE DA™ Master Link & Assembly have a design factor of 5 to enable them to operate in the harshest environments.

DNV 2.7-1 Specified Test Certificate

Test certificate with material and manufacturing process specified in DNV 2.7-1 for complete traceability.

To perform in the harshest weather and roughest sea conditions, YOKE DA™ Series are specially designed, manufactured and tested for the operating in the offshore container industry.



DNV·GL

Certificate No:
TAS000025Z

TYPE APPROVAL CERTIFICATE

This is to certify:

That the lifting set components for offshore containers and portable offshore units

with type designation(s)

- Master Link - Type DA-001**
- Master Link - Type DA-001F**
- Master Link Assembly - Type DA-007**
- Master Link Assembly - Type DA-007F**

Issued to

Yoke Industrial Corp. Ltd.
Taichung, Taiwan

is found to comply with

- DNV GL standard DNVGL-ST-E271 – 2.7-1 Offshore containers, August 2017**
- DNV GL standard DNVGL-ST-E273 – 2.7-3 Portable offshore units, December 2016**
- EN 1677-4 Components for slings – Safety – Part 4: Links, Grade 8**
- ISO 10855-2:2018 Offshore containers and associated liftings sets – Part 2: Design, manufacture and testing of lifting sets**
- IMO/MSC Circular 860**

Application :

Grade 8 links for lifting sets for offshore containers or portable offshore units

Issued at **Aberdeen** on **2020-11-09**

This Certificate is valid until **2025-11-08** .

DNV GL local unit: **Kaohsiung**

Approval Engineer: **Alex Doig**



Elisabeth Legg
Principal Engineer

This Certificate is subject to terms and conditions overlaid. Any significant change in design or construction may render this Certificate invalid. The validity date relates to the Type Approval Certificate and not to the approval of equipment/systems installed.

LEGAL DISCLAIMER: Unless otherwise stated in the applicable contract with the holder of this document, or following from mandatory law, the liability of DNV GL AS, its parent companies and subsidiaries as well as their officers, directors and employees ("DNV GL") arising from or in connection with the services rendered for the purpose of the issuance of this document or reliance thereon, whether in contract or in tort (including negligence), shall be limited to direct losses and under any circumstance be limited to 300,000 USD.



Form code: TA 281

Revision: 2020-03

www.dnvgl.com

Page 1 of 5

© DNV GL 2014. DNV GL and the Horizon Graphic are trademarks of DNV GL AS.

DNV·GL

Certificate No:
TAS0000241

TYPE APPROVAL CERTIFICATE

This is to certify:

That the Lifting set for Offshore containers and Portable Offshore Units

with type designation(s)

Bolt Pin Anchor Shackles - Type DA-808 - Design Temperature -40°C

Bolt Pin Anchor Shackles - Type DA-838 - Design Temperature -40°C

Issued to

Yoke Industrial Corp.

Taichung, Taiwan

is found to comply with

DNV GL standard DNVGL-ST-E271 – 2.7-1 Offshore containers, August 2017

DNV GL standard DNVGL-ST-E273 – 2.7-3 Portable offshore units, December 2016

EN 13889 Forged steel shackles for general lifting purposes - Dee shackles and Bow shackles

- Grade 6 - Safety

ISO 10855-2:2018 Offshore containers and associated liftings sets – Part 2: Design, manufacture and testing of lifting sets

IMO/MSC Circular 860

Application :

Shackles for Lifting Sets for Offshore Containers and Portable Offshore Units

Issued at **Høvik** on **2019-07-24**

This Certificate is valid until **2024-06-29**.

DNV GL local station: **Kaohsiung**

Approval Engineer: **Nina Thorvaldsen Moberg**



for **DNV GL**
Digitally Signed By: **Hals,**
Inger-Helene
Signing Date: **13.08.2019**
Location: **Høvik, Norway**

Inger-Helene Hals
Head of Section

Stu

This Certificate is subject to terms and conditions overleaf. Any significant change in design or construction may render this Certificate invalid. The validity date relates to the Type Approval Certificate and not to the approval of equipment/systems installed.



Form code: TA 251

Revision: 2016-12

www.dnvgl.com

Page 1 of 4

© DNV GL 2014. DNV GL and the Horizon Graphic are trademarks of DNV GL AS.

**DNV·GL**Certificate No:
TAS000011K

TYPE APPROVAL CERTIFICATE

This is to certify:**That the Hook**with type designation(s)
Hooks DA-025 & DA-027NIssued to
Yoke Industrial Corp.
Taichung, Taiwanis found to comply with
DNV GL standard DNVGL-ST-0378 – Standard for offshore and platform lifting appliances**Application :****Product(s) approved by this certificate is/are accepted for installation on all vessels classed by DNV GL.**Issued at **Høvik** on **2017-05-31**This Certificate is valid until **2022-05-30**.
DNV GL local station: **Kaohsiung**Approval Engineer: **Antonio Sendin Alvarez**for **DNV GL**Digitally Signed By: **aldo.matteucci@dnvgl.com**
Location: **DNV GL Høvik, Norway**
Signing Date: **01.06.2017****Aldo Matteucci**
Head of Section

This Certificate is subject to terms and conditions overleaf. Any significant change in design or construction may render this Certificate invalid. The validity date relates to the Type Approval Certificate and not to the approval of equipment/systems installed.

Form code: TA 251

Revision: 2016-12

www.dnvgl.com

Page 1 of 3

© DNV GL 2014. DNV GL and the Horizon Graphic are trademarks of DNV GL AS.



DNV·GL

Certificate No:
TAS00000T4

TYPE APPROVAL CERTIFICATE

This is to certify:

That the Chain, shackles, swivels, sockets

with type designation(s)
Lifting points DA-271 for offshore cranes

Issued to
Yoke Industrial Corp.
Taichung, Taiwan

is found to comply with
DNV GL standard DNVGL-ST-0378 – Standard for offshore and platform lifting appliances

Application :

Product(s) approved by this certificate is/are accepted for installation on all vessels classed by DNV GL.

This Certificate is valid until **2022-05-29**.

Issued at **Høvik** on **2017-05-30**

DNV GL local station: **Kaohsiung**

Approval Engineer: **Antonio Sendin Alvarez**

for **DNV GL**



Digitally Signed By: aldo.matteucci@dnv.com
Location: DNV GL Høvik, Norway
Signing Date: 31.05.2017

Aldo Matteucci
Head of Section

This Certificate is subject to terms and conditions overleaf. Any significant change in design or construction may render this Certificate invalid. The validity date relates to the Type Approval Certificate and not to the approval of equipment/systems installed.

Determination of Working Load Limit

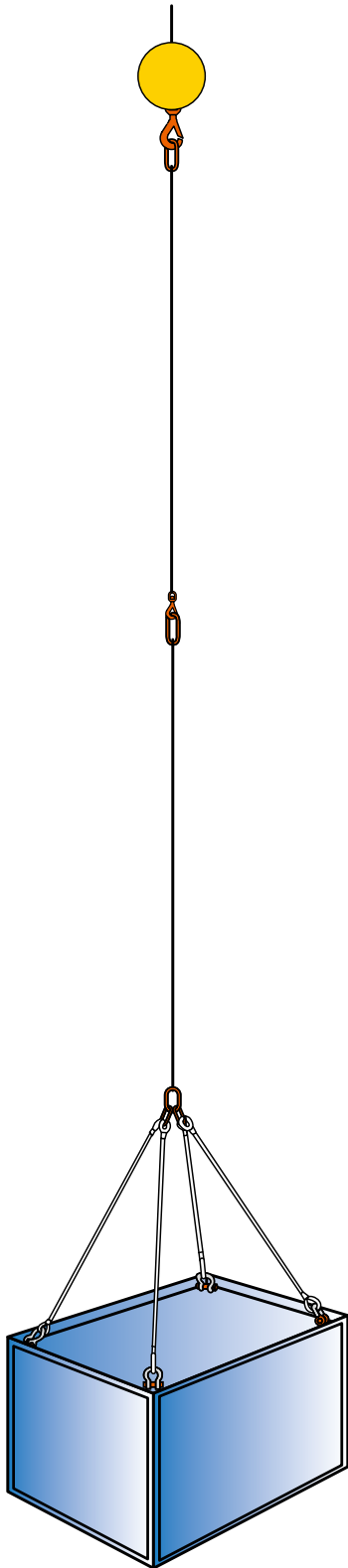

| Table 8-1 Determination of Working Load Limit | | |
|---|--------------------|--|
| Rating(kg) | Enhancement factor | Minimum required Working Load Limit(WLLmin)(t) |
| 500 | - | 7.00 |
| 1000 | - | 7.00 |
| 1500 | - | 7.00 |
| 2000 | 3.500 | 7.00 |
| 2500 | 2.880 | 7.20 |
| 3000 | 2.600 | 7.80 |
| 3500 | 2.403 | 8.41 |
| 4000 | 2.207 | 8.83 |
| 4500 | 2.067 | 9.30 |
| 5000 | 1.960 | 9.80 |
| 5500 | 1.873 | 10.30 |
| 6000 | 1.766 | 10.60 |
| 6500 | 1.733 | 11.26 |
| 7000 | 1.700 | 11.90 |
| 7500 | 1.666 | 12.50 |
| 8000 | 1.633 | 13.07 |
| 8500 | 1.600 | 13.60 |
| 9000 | 1.567 | 14.10 |
| 9500 | 1.543 | 14.57 |
| 10000 | 1.501 | 15.01 |
| 10500 | 1.479 | 15.53 |
| 11000 | 1.457 | 16.02 |
| 11500 | 1.435 | 16.50 |
| 12000 | 1.413 | 16.95 |
| 12500 | 1.931 | 17.38 |
| 13000 | 1.368 | 17.79 |
| 13500 | 1.346 | 18.18 |
| 14000 | 1.324 | 18.54 |
| 14500 | 1.302 | 18.88 |
| 15000 | 1.280 | 19.20 |
| 15500 | 1.267 | 19.64 |
| 16000 | 1.254 | 20.06 |
| 16500 | 1.240 | 20.47 |
| 17000 | 1.227 | 20.86 |
| 17500 | 1.214 | 21.24 |
| 18000 | 1.201 | 21.61 |
| 18500 | 1.188 | 21.97 |
| 19000 | 1.174 | 22.31 |
| 19500 | 1.161 | 22.64 |
| 20000 | 1.148 | 22.96 |
| 20500 | 1.143 | 23.44 |
| 21000 | 1.139 | 23.92 |
| 21500 | 1.135 | 24.39 |
| 22000 | 1.130 | 24.86 |
| 22500 | 1.126 | 25.33 |
| 23000 | 1.121 | 25.79 |
| 23500 | 1.117 | 26.25 |
| 24000 | 1.112 | 26.70 |
| 24500 | 1.108 | 27.15 |
| 25000 | 1.104 | 27.59 |

Safety is our first priority™
- Quality, Reliability, Innovation -

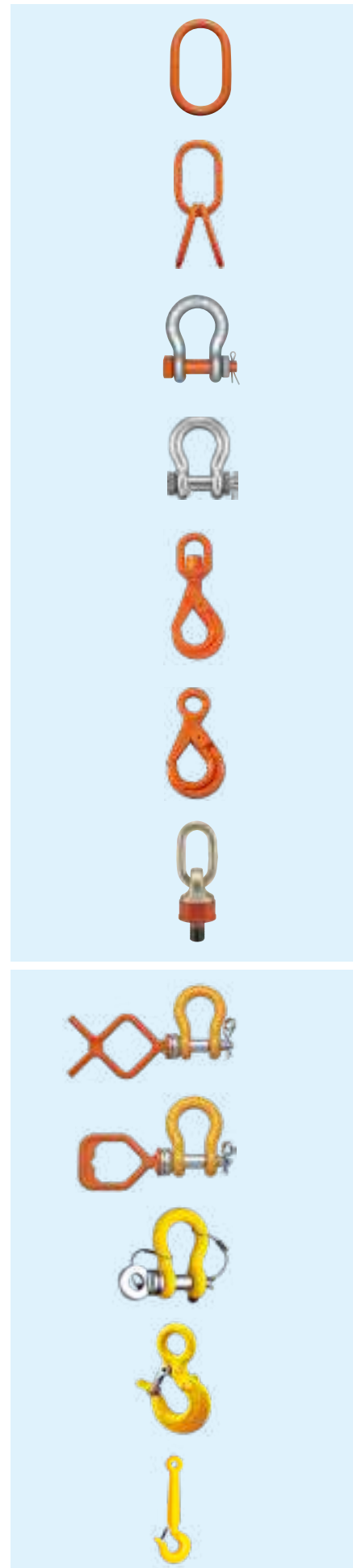

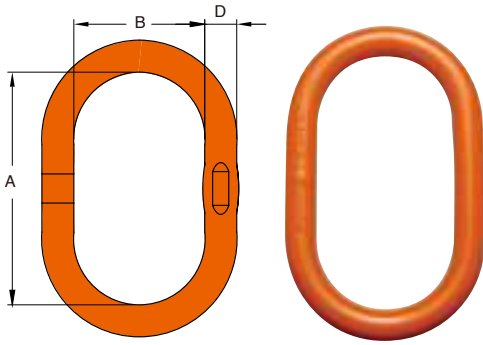

- Welded alloy steel, quenched and tempered.
- Tested and manufactured in accordance with DNV GL ST-2.7-1, EN 1677-4, ASME B30.26.
- Certified by DNV GL ST-2.7-1.
- Fatigue rated to 20,000 cycles at 1.5 times the Working Load Limit (WLL).
- Charpy tested in accordance with DNV GL ST-2.7-1.
- Proof Load tested to 2.5 times the Working Load Limit (WLL).
- Design factor 5:1.
- Charpy test of 42 joules (31ft. lbs.) at -40°C (-40°F) for normal section.
- Charpy test of 27 joules (20ft. lbs.) at -40°C (-40°F) for welded section.

DA Master Link

**DNV GL ST-2.7-1
(Offshore Containers)**



"can be used to single hook according to DIN 15401 NO."

| Item No. | Code NO. | WLL | Proof Load | "can be used to single hook according to DIN 15401 NO." | Dimensions (inch) | | | N.W. |
|------------|----------|-------------------|------------|---|-------------------|-------|------|------|
| | | β 0-45° tonnes | | | kN | D | A | |
| DA-001-13 | FD-13 | 2.8 | 69 | 2.5 | 0.51 | 4.72 | 2.36 | 0.8 |
| DA-001-16 | FD-16 | 4.0 | 98 | 6.0 | 0.63 | 6.30 | 3.54 | 1.6 |
| DA-001-19 | FD-19 | 6.7 | 164 | 6.0 | 0.75 | 6.30 | 3.54 | 2.4 |
| DA-001-22 | FD-22 | 8.9 | 218 | 8.0 | 0.87 | 7.09 | 3.94 | 3.6 |
| DA-001-223 | FD-223 | 6.3 | 154 | 16.0 | 0.87 | 10.63 | 5.51 | 5.0 |
| DA-001-25 | FD-25 | 11.5 | 282 | 10.0 | 0.98 | 8.27 | 4.53 | 5.3 |
| DA-001-251 | FD-251 | 11.5 | 282 | 16.0 | 0.98 | 10.83 | 5.71 | 6.7 |
| DA-001-28 | FD-28 | 13.0 | 319 | 16.0 | 1.10 | 10.83 | 5.71 | 8.5 |
| DA-001-32 | FD-32 | 17.1 | 419 | 16.0 | 1.26 | 10.83 | 5.71 | 11.3 |
| DA-001-36 | FD-36 | 24.0 | 588 | 20.0 | 1.42 | 11.22 | 6.10 | 15.1 |
| DA-001-40 | FD-40 | 28.1 | 688 | 20.0 | 1.57 | 11.81 | 6.30 | 19.7 |
| DA-001-45 | FD-45 | 38.3 | 938 | 25.0 | 1.77 | 13.39 | 7.09 | 28.2 |
| DA-001-50 | FD-50 | 45.0 | 1103 | 32.0 | 1.97 | 13.78 | 7.68 | 36.6 |

*Welded Master Link *Design Factor 5:1 *Proof tested at 2.5 times the WLL

| Item No. | Code NO. | WLL | Proof Load | "can be used to single hook according to DIN 15401 NO." | Dimensions (mm) | | | N.W. |
|------------|----------|-------------------|------------|---|-----------------|-----|-----|------|
| | | β 0-45° tonnes | | | kN | D | A | |
| DA-001-13 | FD-13 | 2.8 | 69 | 2.5 | 13 | 120 | 60 | 0.4 |
| DA-001-16 | FD-16 | 4.0 | 98 | 6.0 | 16 | 160 | 90 | 0.7 |
| DA-001-19 | FD-19 | 6.7 | 164 | 6.0 | 19 | 160 | 90 | 1.1 |
| DA-001-22 | FD-22 | 8.9 | 218 | 8.0 | 22 | 180 | 100 | 1.6 |
| DA-001-223 | FD-223 | 6.3 | 154 | 16.0 | 22 | 270 | 140 | 2.3 |
| DA-001-25 | FD-25 | 11.5 | 282 | 10.0 | 25 | 210 | 115 | 2.4 |
| DA-001-251 | FD-251 | 11.5 | 282 | 16.0 | 25 | 275 | 145 | 3.1 |
| DA-001-28 | FD-28 | 13.0 | 319 | 16.0 | 28 | 275 | 145 | 3.9 |
| DA-001-32 | FD-32 | 17.1 | 419 | 16.0 | 32 | 275 | 145 | 5.1 |
| DA-001-36 | FD-36 | 24.0 | 588 | 20.0 | 36 | 285 | 155 | 6.9 |
| DA-001-40 | FD-40 | 28.1 | 688 | 20.0 | 40 | 300 | 160 | 8.9 |
| DA-001-45 | FD-45 | 38.3 | 938 | 25.0 | 45 | 340 | 180 | 12.8 |
| DA-001-50 | FD-50 | 45.0 | 1103 | 32.0 | 50 | 350 | 195 | 16.6 |

Sub-links SPEC for DA-007. Items in grey area are not for sale individually.

| | | | | | | | | |
|------------|--------|------|-----|------|----|-----|-----|-----|
| DA-001-131 | FD-131 | 2.8 | 69 | 1.6 | 13 | 90 | 50 | 0.3 |
| DA-001-161 | FD-161 | 4.0 | 98 | 4.0 | 16 | 140 | 70 | 0.6 |
| DA-001-191 | FD-191 | 6.7 | 164 | 4.0 | 19 | 140 | 70 | 0.9 |
| DA-001-221 | FD-221 | 8.9 | 218 | 6.0 | 22 | 140 | 70 | 1.3 |
| DA-001-222 | FD-222 | 8.9 | 218 | 6.0 | 22 | 162 | 90 | 1.5 |
| DA-001-281 | FD-281 | 13.0 | 319 | 8.0 | 28 | 190 | 100 | 2.8 |
| DA-001-282 | FD-282 | 14.5 | 355 | 10.0 | 28 | 200 | 110 | 3.0 |
| DA-001-361 | FD-361 | 24.0 | 588 | 16.0 | 36 | 275 | 145 | 6.6 |
| DA-001-401 | FD-401 | 28.1 | 688 | 12.0 | 40 | 260 | 130 | 7.8 |

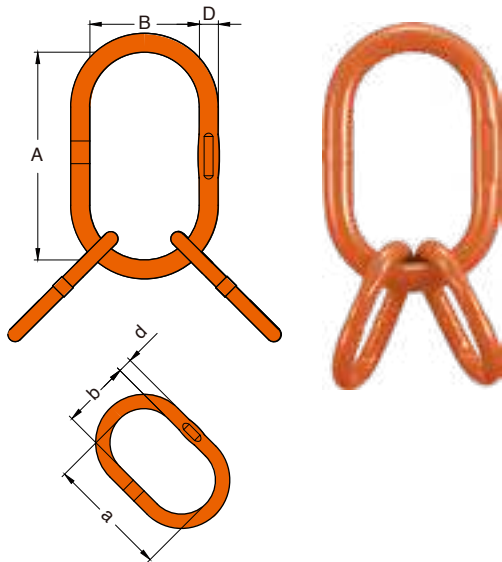

- Welded alloy steel, quenched and tempered.
- Tested and manufactured in accordance with DNV GL ST-2.7-1, EN 1677-4, ASME B30.26.
- Certified by DNV GL ST-2.7-1.
- Fatigue rated to 20,000 cycles at 1.5 times the Working Load Limit (WLL).
- Charpy tested in accordance with DNV GL ST-2.7-1.
- Proof Load tested to 2.5 times the Working Load Limit (WLL).
- Design factor 5:1.
- Charpy test of 42 joules (31ft. lbs.) at -40°C (-40°F) for normal section.
- Charpy test of 27 joules (20ft. lbs.) at -40°C (-40°F) for welded section.

DA Master Link Assembly

DNV GL ST-2.7-1
(Offshore Containers)

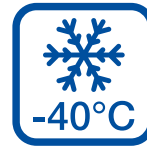

| Item No. | Assembled with. | WLL β 0-45° tonnes | Proof Load kN | "can be used to single hook according to DIN 15401 NO." | Dimensions (inch) | | | | | | N.W. lbs |
|------------|------------------|--------------------------|------------------|---|-------------------|-------|------|------|-------|------|-------------|
| | | | | | D | A | B | d | a | b | |
| DA-007-16 | FD-161 +2 FD-131 | 4.1 | 100 | 4 | 0.63 | 5.51 | 2.76 | 0.51 | 3.54 | 1.97 | 2.7 |
| DA-007-22 | FD-222 +2 FD-191 | 8.9 | 218 | 6 | 0.87 | 6.38 | 3.54 | 0.75 | 5.51 | 2.76 | 7.4 |
| DA-007-221 | FD-223 +2 FD-161 | 6.3 | 154 | 16 | 0.87 | 10.63 | 5.51 | 0.63 | 5.51 | 2.76 | 7.9 |
| DA-007-25 | FD-251 +2 FD-19 | 8.9 | 218 | 16 | 0.98 | 10.83 | 5.71 | 0.75 | 6.30 | 3.54 | 11.5 |
| DA-007-28 | FD-28 +2 FD-22 | 12.9 | 316 | 16 | 1.10 | 10.83 | 5.71 | 0.87 | 7.09 | 3.94 | 15.7 |
| DA-007-281 | FD-282 +2 FD-221 | 14.5 | 355 | 10 | 1.10 | 7.87 | 4.33 | 0.87 | 5.51 | 2.76 | 12.2 |
| DA-007-32 | FD-32 +2 FD-25 | 17.0 | 417 | 16 | 1.26 | 10.83 | 5.71 | 0.98 | 8.27 | 4.53 | 22.0 |
| DA-007-36 | FD-361 +2 FD-281 | 23.6 | 578 | 16 | 1.42 | 10.83 | 5.71 | 1.10 | 7.48 | 3.94 | 26.9 |
| DA-007-40 | FD-40 +2 FD-32 | 28.1 | 688 | 20 | 1.57 | 11.81 | 6.30 | 1.26 | 10.83 | 5.71 | 42.4 |
| DA-007-45 | FD-45 +2 FD-36 | 38.3 | 938 | 25 | 1.77 | 13.39 | 7.09 | 1.42 | 11.22 | 6.10 | 58.4 |
| DA-007-50 | FD-50 +2 FD-401 | 45.0 | 1103 | 32 | 1.97 | 13.78 | 7.68 | 1.57 | 10.24 | 5.12 | 71.1 |

*Welded Master Link

*Design Factor 5:1

*Proof tested at 2.5 times the WLL

| Item No. | Assembled with. | WLL β 0-45° tonnes | Proof Load kN | "can be used to single hook according to DIN 15401 NO." | Dimensions (mm) | | | | | | N.W. kg |
|------------|------------------|--------------------------|------------------|---|-----------------|-----|-----|----|-----|-----|------------|
| | | | | | D | A | B | d | a | b | |
| DA-007-16 | FD-161 +2 FD131 | 4.1 | 100 | 4 | 16 | 140 | 70 | 13 | 90 | 50 | 1.2 |
| DA-007-22 | FD-222 +2 FD191 | 8.9 | 218 | 6 | 22 | 162 | 90 | 19 | 140 | 70 | 3.3 |
| DA-007-221 | FD-223 +2 FD161 | 6.3 | 154 | 16 | 22 | 270 | 140 | 16 | 140 | 70 | 3.6 |
| DA-007-25 | FD-251 +2 FD-19 | 8.9 | 218 | 16 | 25 | 275 | 145 | 19 | 160 | 90 | 5.2 |
| DA-007-28 | FD-28 +2 FD-22 | 12.9 | 316 | 16 | 28 | 275 | 145 | 22 | 180 | 100 | 7.1 |
| DA-007-281 | FD-282 +2 FD-221 | 14.5 | 355 | 10 | 28 | 200 | 110 | 22 | 140 | 70 | 5.5 |
| DA-007-32 | FD-32 +2 FD-25 | 17.0 | 417 | 16 | 32 | 275 | 145 | 25 | 210 | 115 | 10.0 |
| DA-007-36 | FD-361 +2 FD-281 | 23.6 | 578 | 16 | 36 | 275 | 145 | 28 | 190 | 100 | 12.2 |
| DA-007-40 | FD-40 +2 FD-32 | 28.1 | 688 | 20 | 40 | 300 | 160 | 32 | 275 | 145 | 19.2 |
| DA-007-45 | FD-45 +2 FD-36 | 38.3 | 938 | 25 | 45 | 340 | 180 | 36 | 285 | 155 | 26.5 |
| DA-007-50 | FD-50 +2 FD-401 | 45.0 | 1103 | 32 | 50 | 350 | 195 | 40 | 260 | 130 | 32.3 |

*Welded Master Link

*Design Factor 5:1

*Proof tested at 2.5 times the WLL

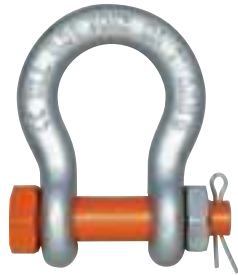
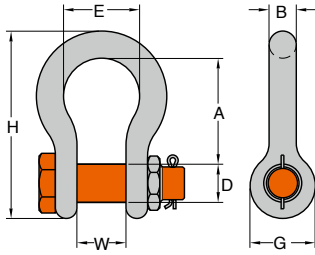

- Forged Carbon steel, quenched and tempered.
- Tested and manufactured in accordance with DNV GL ST-2.7-1, DNV GL-ST-0378, EN 13889, ASME B30.26, U.S. Fed. Spec. RR-C-271F Type IVA, Grade A, Class 3.
- Certified by DNV GL ST-2.7-1.
- Fatigue rated to 20,000 cycles at 1.5 times the Working Load Limit (WLL).
- Charpy tested in accordance with DNV GL ST-2.7-1.
- Hot dip galvanized.
- Charpy test of 42 joules (31ft. lbs.) at -40°C (-40°F) for normal section.

DA 838 Shackle

Grade 6

**DNV GL ST-2.7-1
(Offshore Containers)**

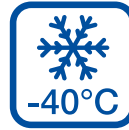

| Item No. | Nominal Size | Working Load Limit | Dimensions (inch) | | | | | | | N.W. |
|------------|--------------|--------------------|-------------------|------|------|-------|------|-------|------|-------|
| | inch | | tonnes* | A | B | D | E | G | H | |
| DA-838-13 | 1/2 | 2.00 | 1.93 | 0.52 | 0.63 | 1.30 | 1.18 | 3.34 | 0.79 | 0.9 |
| DA-838-16 | 5/8 | 3.25 | 2.40 | 0.63 | 0.75 | 1.70 | 1.50 | 4.17 | 1.06 | 1.5 |
| DA-838-19 | 3/4 | 4.75 | 2.83 | 0.75 | 0.87 | 1.97 | 1.81 | 5.04 | 1.30 | 2.2 |
| DA-838-22 | 7/8 | 6.50 | 3.39 | 0.87 | 0.98 | 2.28 | 2.09 | 5.91 | 1.50 | 3.7 |
| DA-838-26 | 1 | 8.50 | 3.78 | 1.02 | 1.10 | 2.68 | 2.40 | 6.57 | 1.73 | 5.3 |
| DA-838-28 | 1- 1/8 | 9.50 | 4.37 | 1.10 | 1.26 | 2.91 | 2.68 | 7.52 | 1.81 | 7.5 |
| DA-838-32 | 1- 1/4 | 12.00 | 4.84 | 1.26 | 1.42 | 3.30 | 2.99 | 8.07 | 2.12 | 10.6 |
| DA-838-36 | 1- 3/8 | 13.50 | 5.28 | 1.42 | 1.50 | 3.62 | 3.31 | 9.13 | 2.32 | 14.3 |
| DA-838-38 | 1- 1/2 | 17.00 | 5.57 | 1.50 | 1.69 | 3.90 | 3.62 | 10.00 | 2.36 | 19.4 |
| DA-838-45 | 1- 3/4 | 25.00 | 7.00 | 1.85 | 2.00 | 5.00 | 4.17 | 12.32 | 2.87 | 38.5 |
| DA-838-50 | 2 | 35.00 | 7.76 | 2.09 | 2.24 | 5.75 | 4.80 | 13.66 | 3.27 | 53.2 |
| DA-838-64 | 2- 1/2 | ** 55.00 | 10.51 | 2.62 | 2.76 | 7.24 | 5.91 | 17.95 | 4.13 | 95.7 |
| DA-838-76 | 3 | ** 85.00 | 12.99 | 3.11 | 3.25 | 7.87 | 6.61 | 21.57 | 5.00 | 178.2 |
| DA-838-89 | 3- 1/2 | **120.00 | 14.65 | 3.62 | 3.76 | 9.02 | 7.99 | 24.65 | 5.24 | 264.0 |
| DA-838-100 | 4 | **150.00 | 14.49 | 4.09 | 4.25 | 10.00 | 9.02 | 25.71 | 5.51 | 336.6 |

*2t to 35t are type approved of DNV 2.7-1. Minimum Ultimate Load is 6 times the Working Load Limit.

**55t to 150t meet all requirements of DNV 2.7-1. Minimum Ultimate Load is 6 times the Working Load Limit.

| Item No. | Nominal Size | Working Load Limit | Dimensions (mm) | | | | | | | N.W. |
|------------|--------------|--------------------|-----------------|-------|------|-----|-----|-----|-----|-------|
| | mm | | tonnes* | A | B | D | E | G | H | |
| DA-838-13 | 13 | 2.00 | 49 | 13.0 | 16 | 33 | 30 | 85 | 20 | 0.4 |
| DA-838-16 | 16 | 3.25 | 61 | 16.0 | 19 | 43 | 38 | 106 | 27 | 0.7 |
| DA-838-19 | 19 | 4.75 | 72 | 19.0 | 22 | 50 | 46 | 126 | 33 | 1.0 |
| DA-838-22 | 22 | 6.50 | 86 | 22.0 | 25 | 58 | 53 | 148 | 38 | 1.7 |
| DA-838-26 | 26 | 8.50 | 96 | 26.0 | 28 | 68 | 61 | 166 | 44 | 2.4 |
| DA-838-28 | 28 | 9.50 | 111 | 28.0 | 32 | 74 | 68 | 190 | 46 | 3.4 |
| DA-838-32 | 32 | 12.00 | 123 | 32.0 | 36 | 84 | 76 | 210 | 54 | 4.8 |
| DA-838-36 | 36 | 13.50 | 134 | 36.0 | 38 | 92 | 84 | 232 | 59 | 6.5 |
| DA-838-38 | 38 | 17.00 | 146 | 38.0 | 43 | 99 | 92 | 254 | 60 | 8.8 |
| DA-838-45 | 45 | 25.00 | 178 | 47.0 | 51 | 127 | 106 | 313 | 73 | 17.5 |
| DA-838-50 | 50 | 35.00 | 197 | 53.0 | 57 | 146 | 122 | 347 | 83 | 24.2 |
| DA-838-64 | 64 | ** 55.00 | 267 | 66.5 | 70 | 184 | 150 | 456 | 105 | 43.5 |
| DA-838-76 | 76 | ** 85.00 | 330 | 79.0 | 82.5 | 200 | 168 | 548 | 127 | 81.0 |
| DA-838-89 | 89 | **120.00 | 372 | 92.0 | 95.5 | 229 | 203 | 626 | 133 | 120.0 |
| DA-838-100 | 100 | **150.00 | 368 | 104.0 | 108 | 254 | 229 | 653 | 140 | 153.0 |

*2t to 35t are type approved of DNV 2.7-1. Minimum Ultimate Load is 6 times the Working Load Limit.

**55t to 150t meet all requirements of DNV 2.7-1. Minimum Ultimate Load is 6 times the Working Load Limit.



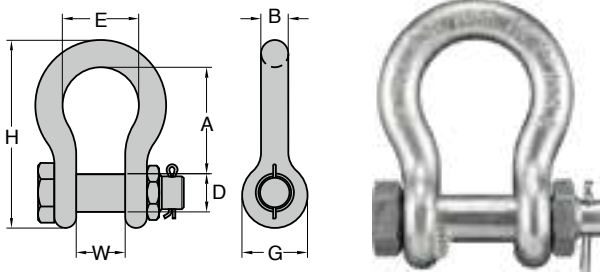

- Forged alloy steel, quenched and tempered.
- Tested and manufactured in accordance with DNV GL ST-2.7-1, DNV GL-ST-0378, EN 13889, ASME B30.26, U.S. Fed. Spec. RR-C-271F Type IVA, Grade A, Class 3.
- Certified by DNV GL ST-2.7-1.
- Fatigue rated to 20,000 cycles at 1.5 times the Working Load Limit (WLL).
- Charpy tested in accordance with DNV GL ST-2.7-1.
- Hot dip galvanized.
- Charpy test of 42 joules (31ft. lbs.) at -40°C (-40°F) for normal section.

DA 808 Shackle

Grade 8

DNV GL ST-2.7-1
(Offshore Containers)

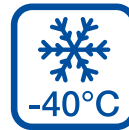

| Item No. | Nominal Size | Working Load Limit tonnes* | Dimensions (inch) | | | | | | | N.W. lbs |
|------------|--------------|-------------------------------|-------------------|------|------|-------|------|-------|------|-------------|
| | inch | | A | B | D | E | G | H | W | |
| DA-808-13 | 1/2 | 2.00 | 1.93 | 0.52 | 0.63 | 1.30 | 1.18 | 3.34 | 0.79 | 0.9 |
| DA-808-16 | 5/8 | 3.25 | 2.40 | 0.63 | 0.75 | 1.70 | 1.50 | 4.17 | 1.06 | 1.5 |
| DA-808-19 | 3/4 | 4.75 | 2.83 | 0.75 | 0.87 | 1.97 | 1.81 | 5.04 | 1.30 | 2.2 |
| DA-808-22 | 7/8 | 6.50 | 3.39 | 0.87 | 0.98 | 2.28 | 2.09 | 5.91 | 1.50 | 3.7 |
| DA-808-26 | 1 | 8.50 | 3.78 | 1.02 | 1.10 | 2.68 | 2.40 | 6.57 | 1.73 | 5.3 |
| DA-808-28 | 1- 1/8 | 9.50 | 4.37 | 1.10 | 1.26 | 2.91 | 2.68 | 7.52 | 1.81 | 7.5 |
| DA-808-32 | 1- 1/4 | 12.00 | 4.84 | 1.26 | 1.42 | 3.30 | 2.99 | 8.07 | 2.12 | 10.6 |
| DA-808-36 | 1- 3/8 | 13.50 | 5.28 | 1.42 | 1.50 | 3.62 | 3.31 | 9.13 | 2.32 | 14.3 |
| DA-808-38 | 1- 1/2 | 17.00 | 5.57 | 1.50 | 1.69 | 3.90 | 3.62 | 10.00 | 2.36 | 19.4 |
| DA-808-45 | 1- 3/4 | 25.00 | 7.00 | 1.85 | 2.00 | 5.00 | 4.17 | 12.32 | 2.87 | 38.5 |
| DA-808-50 | 2 | 35.00 | 7.76 | 2.09 | 2.24 | 5.75 | 4.80 | 13.66 | 3.27 | 53.2 |
| DA-808-64 | 2- 1/2 | ** 85.00 | 10.51 | 2.62 | 2.76 | 7.24 | 5.91 | 17.95 | 4.13 | 95.7 |
| DA-808-76 | 3 | **120.00 | 12.99 | 3.11 | 3.25 | 7.87 | 6.61 | 21.57 | 5.00 | 178.2 |
| DA-808-89 | 3- 1/2 | **150.00 | 14.65 | 3.62 | 3.76 | 9.02 | 7.99 | 24.65 | 5.24 | 264.0 |
| DA-808-100 | 4 | **175.00 | 14.49 | 4.09 | 4.25 | 10.00 | 9.02 | 25.71 | 5.51 | 336.6 |

*2t to 35t are type approved of DNV 2.7-1. Minimum Ultimate Load is 8 times the Working Load Limit.

**85t to 175t meet all requirements of DNV 2.7-1. Minimum Ultimate Load is 5.4 times the Working Load Limit.

| Item No. | Nominal Size | Working Load Limit tonnes* | Dimensions (mm) | | | | | | | N.W. kg |
|------------|--------------|-------------------------------|-----------------|-------|-------|-----|-----|-----|-----|------------|
| | mm | | A | B | D | E | G | H | W | |
| DA-808-13 | 13 | 2.00 | 49 | 13.0 | 16.0 | 33 | 30 | 85 | 20 | 0.4 |
| DA-808-16 | 16 | 3.25 | 61 | 16.0 | 19.0 | 43 | 38 | 106 | 27 | 0.7 |
| DA-808-19 | 19 | 4.75 | 72 | 19.0 | 22.0 | 50 | 46 | 126 | 33 | 1.0 |
| DA-808-22 | 22 | 6.50 | 86 | 22.0 | 25.0 | 58 | 53 | 148 | 38 | 1.7 |
| DA-808-26 | 26 | 8.50 | 96 | 26.0 | 28.0 | 68 | 61 | 166 | 44 | 2.4 |
| DA-808-28 | 28 | 9.50 | 111 | 28.0 | 32.0 | 74 | 68 | 190 | 46 | 3.4 |
| DA-808-32 | 32 | 12.00 | 123 | 32.0 | 36.0 | 84 | 76 | 210 | 54 | 4.8 |
| DA-808-36 | 36 | 13.50 | 134 | 36.0 | 38.0 | 92 | 84 | 232 | 59 | 6.5 |
| DA-808-38 | 38 | 17.00 | 146 | 38.0 | 43.0 | 99 | 92 | 254 | 60 | 8.8 |
| DA-808-45 | 45 | 25.00 | 178 | 47.0 | 51.0 | 127 | 106 | 313 | 73 | 17.5 |
| DA-808-50 | 50 | 35.00 | 197 | 53.0 | 57.0 | 146 | 122 | 347 | 83 | 24.2 |
| DA-808-64 | 64 | ** 85.00 | 267 | 66.5 | 70.0 | 184 | 150 | 456 | 105 | 43.5 |
| DA-808-76 | 76 | **120.00 | 330 | 79.0 | 82.5 | 200 | 168 | 548 | 127 | 81.0 |
| DA-808-89 | 89 | **150.00 | 372 | 92.0 | 95.5 | 229 | 203 | 626 | 133 | 120.0 |
| DA-808-100 | 100 | **175.00 | 368 | 104.0 | 108.0 | 254 | 229 | 653 | 140 | 153.0 |

*2t to 35t are type approved of DNV 2.7-1. Minimum Ultimate Load is 8 times the Working Load Limit.

**85t to 175t meet all requirements of DNV 2.7-1. Minimum Ultimate Load is 5.4 times the Working Load Limit.

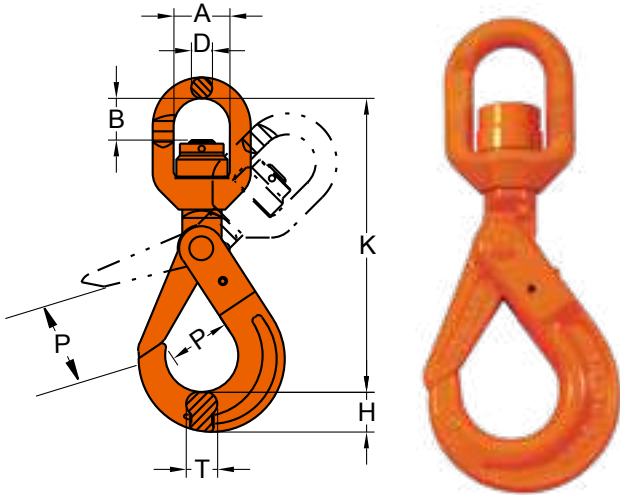

- Forged alloy steel, quenched and tempered.
- Tested and manufactured in accordance with EN 1677 and Norsok R002.
- Certified by DNV GL-ST-0378.
- Fatigue rated to 20,000 cycles at 1.5 times the Working Load Limit (WLL).
- Charpy tested in accordance with DNV GL-ST-0378.
- Designed with recessed trigger and ball bearing, providing the locking mechanism being protected against inadvertent opening due to entanglement with any obstruction during lifting.
- Design factor 4:1 and 5:1.
- Latch mechanism is self locking under loading.
- Charpy test of 42 joules (31ft. lbs.) at -20°C (-4°F).



DA Swivel Self Locking Hook

DNV GL-ST-0378
(Offshore and Platform Lifting Appliance)



With Ball Bearing, which performs full swivel under load

| Item No. | Working Load Limit | | Dimensions (inch) | | | | | | | N.W. lbs |
|-------------|--------------------|------|-------------------|------|------|------|-------|------|------|-------------|
| | tonnes | | A | B | D | H | K | P | T | |
| | 5:1 | 4:1 | | | | | | | | |
| DA-027N-13W | 5.3 | 6.7 | 2.40 | 2.52 | 0.91 | 1.54 | 11.61 | 2.01 | 1.18 | 11 |
| DA-027N-16W | 8.0 | 10.0 | 2.91 | 3.66 | 0.98 | 1.93 | 14.53 | 2.36 | 1.42 | 18 |
| DA-027N-20 | 12.8 | 16.0 | 2.91 | 3.23 | 0.98 | 2.56 | 15.24 | 2.76 | 2.09 | 29 |
| DA-027N-22 | 15.2 | 19.0 | 3.82 | 3.74 | 1.30 | 2.48 | 17.99 | 3.15 | 1.93 | 44 |
| DA-027N-26 | 21.2 | 26.5 | 4.84 | 4.53 | 1.65 | 2.72 | 21.06 | 3.90 | 2.20 | 72 |
| DA-027N-32 | 25.2 | 31.5 | 4.84 | 4.53 | 1.65 | 3.19 | 22.95 | 4.72 | 2.48 | 90 |

| Item No. | Working Load Limit | | Dimensions (mm) | | | | | | | N.W. kg |
|-------------|--------------------|------|-----------------|-----|----|----|-----|-----|----|------------|
| | tonnes | | A | B | D | H | K | P | T | |
| | 5:1 | 4:1 | | | | | | | | |
| DA-027N-13W | 5.3 | 6.7 | 61 | 64 | 23 | 39 | 295 | 51 | 30 | 5.0 |
| DA-027N-16W | 8.0 | 10.0 | 74 | 93 | 25 | 49 | 369 | 60 | 36 | 8.1 |
| DA-027N-20 | 12.8 | 16.0 | 74 | 82 | 25 | 65 | 387 | 70 | 53 | 13.0 |
| DA-027N-22 | 15.2 | 19.0 | 97 | 95 | 33 | 63 | 457 | 80 | 49 | 20.0 |
| DA-027N-26 | 21.2 | 26.5 | 123 | 115 | 42 | 69 | 535 | 99 | 56 | 32.7 |
| DA-027N-32 | 25.2 | 31.5 | 123 | 115 | 42 | 81 | 583 | 120 | 63 | 41.0 |

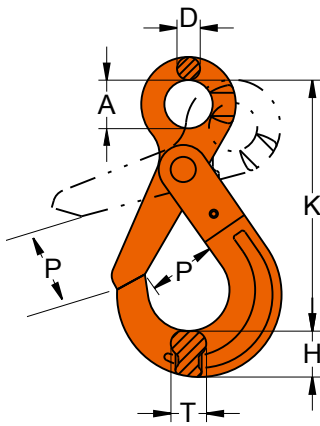

- Forged alloy steel, quenched and tempered.
- Tested and manufactured in accordance with EN 1677 and Norsok R002.
- Certified by DNV GL-ST-0378.
- Fatigue rated to 20,000 cycles at 1.5 times the Working Load Limit (WLL).
- Charpy tested in accordance with DNV GL-ST-0378.
- Designed with recessed trigger, providing the locking mechanism being protected against inadvertent opening due to entanglement with any obstruction during lifting.
- Design factor 4:1 and 5:1.
- Latch mechanism is self locking under loading.
- Charpy test of 42 joules (31ft. lbs.) at -20°C (-4°F).

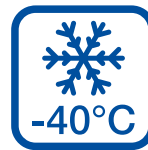

DA Eye Self Locking Hook

DNV GL-ST-0378
(Offshore and Platform Lifting Appliance)



| Item No. | Working Load Limit | | Dimensions (inch) | | | | | | N.W. lbs |
|-----------|--------------------|------|-------------------|------|------|-------|------|------|-------------|
| | tonnes | | A | D | H | K | P | T | |
| | 5:1 | 4:1 | | | | | | | |
| DA-025-13 | 5.3 | 6.7 | 1.57 | 0.63 | 1.54 | 8.15 | 2.05 | 1.18 | 6.6 |
| DA-025-16 | 8.0 | 10.0 | 1.97 | 0.83 | 1.93 | 9.92 | 2.36 | 1.42 | 12.8 |
| DA-025-20 | 12.8 | 16.0 | 2.40 | 0.91 | 2.56 | 11.54 | 2.76 | 1.89 | 22.0 |
| DA-025-22 | 15.2 | 19.0 | 2.76 | 0.94 | 2.48 | 12.56 | 3.15 | 1.93 | 27.5 |
| DA-025-26 | 21.2 | 26.5 | 3.15 | 0.98 | 2.72 | 13.50 | 3.90 | 2.20 | 32.3 |
| DA-025-32 | 25.2 | 31.5 | 3.54 | 1.10 | 3.19 | 15.79 | 4.72 | 2.48 | 57.3 |

| Item No. | Working Load Limit | | Dimensions (mm) | | | | | | N.W. kg |
|-----------|--------------------|------|-----------------|----|----|-----|-----|----|------------|
| | tonnes | | A | D | H | K | P | T | |
| | 5:1 | 4:1 | | | | | | | |
| DA-025-13 | 5.3 | 6.7 | 40 | 16 | 39 | 207 | 52 | 30 | 3.0 |
| DA-025-16 | 8.0 | 10.0 | 50 | 21 | 49 | 252 | 60 | 36 | 5.8 |
| DA-025-20 | 12.8 | 16.0 | 61 | 23 | 65 | 293 | 70 | 48 | 10.0 |
| DA-025-22 | 15.2 | 19.0 | 70 | 24 | 63 | 319 | 80 | 49 | 12.5 |
| DA-025-26 | 21.2 | 26.5 | 80 | 25 | 69 | 343 | 99 | 56 | 14.7 |
| DA-025-32 | 25.2 | 31.5 | 90 | 28 | 81 | 401 | 120 | 63 | 26.0 |

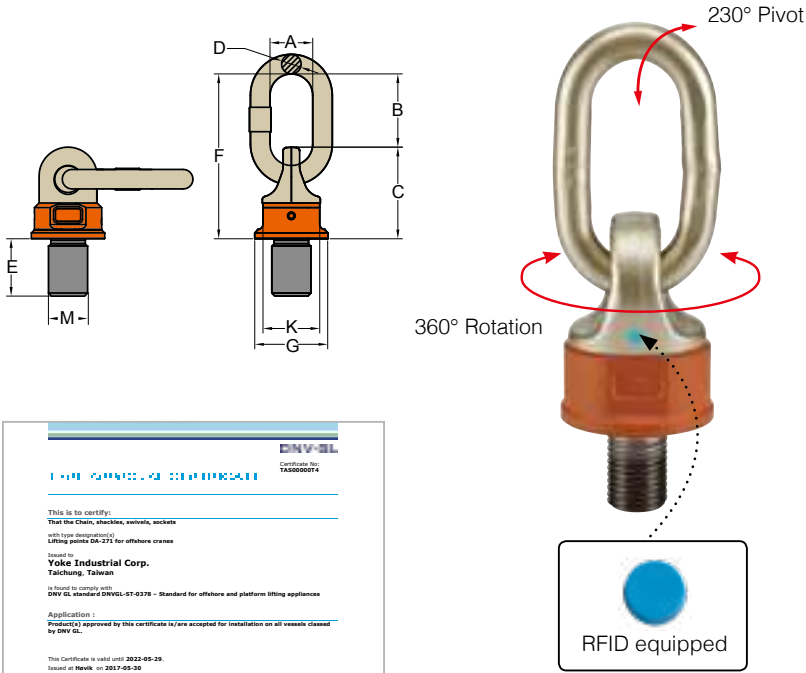

- Pivots to 230°, rotates through 360° due to its unique ball bearing design.
- Manufactured from forged alloy steel, quenched and tempered.
- Tested in accordance with DNV GL–ST-0378.
- Certified by DNV GL–ST-0378.
- Load rated parts are 100% magnaflux crack detected.
- Individual forged parts and batch code links to Test Certificate sheet.
- Bolts are Metric thread.
- Proof tested to 2.5 times the WLL.
- Fatigue rated to 20,000 cycles at 1.5 times the WLL.
- All YOKE Lifting points meet or exceed all the requirements of ASME B30.26.
- Easy to attach or dismantle due to the forged hexagon shaped body of the DA Swivel Point.
- Capable of rotating under load. Do not turn continuously in 90 degree direction at full load.

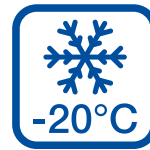
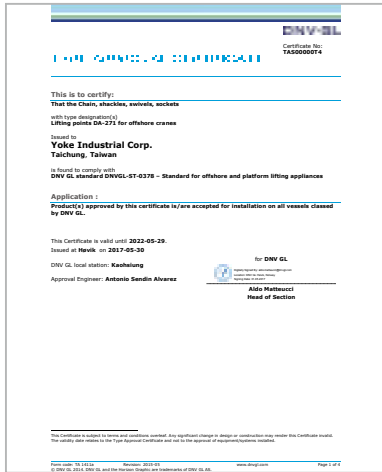

DA Swivel Point Metric Thread (DA-271)

DNV GL-ST-0378
(Offshore and Platform Lifting Appliance)



| Item No. | Working Load Limit tonnes | Thread version | | | Dimensions (mm) | | | | | | | | Torque in Nm | N.W. kg |
|------------|------------------------------|----------------|----|----------------|-----------------|-----|----|----|-----|----|-----|----|--------------------|------------|
| | | M | E | Pitch DIN13 | G | C | K | H | F | D | B | A | | |
| DA-271-003 | 0.4 | M 8 | 12 | 1.25 | 35 | 40 | 30 | 16 | 72 | 8 | 32 | 29 | 10 | 0.2 |
| DA-271-004 | 0.6 | M 10 | 15 | 1.50 | 35 | 40 | 30 | 16 | 72 | 8 | 32 | 29 | 10 | 0.2 |
| DA-271-006 | 0.7 | M 12 | 18 | 1.75 | 40 | 45 | 36 | 18 | 95 | 10 | 50 | 35 | 10 | 0.3 |
| DA-271-013 | 1.5 | M 16 | 24 | 2.00 | 46 | 54 | 41 | 22 | 104 | 13 | 50 | 36 | 30 | 0.5 |
| DA-271-020 | 2.5 | M 20 | 30 | 2.50 | 62 | 68 | 55 | 29 | 122 | 13 | 54 | 36 | 70 | 1.0 |
| DA-271-035 | 4.0 | M 24 | 36 | 3.00 | 78 | 88 | 70 | 36 | 154 | 19 | 66 | 41 | 150 | 2.2 |
| DA-271-060 | 6.0 | M 30 | 45 | 3.50 | 90 | 120 | 80 | 48 | 206 | 22 | 86 | 50 | 350 | 4.5 |
| DA-271-080 | 10.0 | M 36 | 54 | 4.00 | 90 | 120 | 80 | 48 | 206 | 22 | 86 | 50 | 410 | 4.6 |
| DA-271-120 | 13.0 | M 42 | 63 | 4.50 | 98 | 122 | 84 | 50 | 235 | 25 | 110 | 67 | 550 | 5.5 |
| DA-271-130 | 14.0 | M 48 | 72 | 5.00 | 98 | 122 | 84 | 50 | 235 | 25 | 110 | 67 | 550 | 6.1 |
| DA-271-140 | 20.0 | M 52 | 78 | 5.00 | 120 | 150 | 94 | 60 | 270 | 32 | 120 | 72 | 750 | 10.5 |
| DA-271-160 | 20.0 | M 56 | 84 | 5.50 | 120 | 150 | 94 | 60 | 270 | 32 | 120 | 72 | 800 | 10.7 |
| DA-271-161 | 20.0 | M 64 | 96 | 6.00 | 120 | 150 | 94 | 60 | 270 | 32 | 120 | 72 | 800 | 11.6 |

*Design factor 4:1 proof tested and certified.



| Kind of attachment | | | | | | | | | | | | | | | | | | |
|--------------------|----------------|----------------|------|------|------|-------|------|------|-------|-------|------|-----|---------|-----------|---------|---------|-----------|---------|
| | Number of legs | Load direction | 1 | 2 | 1 | 2 | 2 | 2 | 2 | 3-4 | 3-4 | 3-4 | 0 - 45° | 45° - 60° | unsymm. | 0 - 45° | 45° - 60° | unsymm. |
| Item No. | Thread | WLL(t) | | | | | | | | | | | | | | | | |
| DA-271-003 | M 8 | 0.6 | 1.2 | 0.4 | 0.8 | 0.56 | 0.4 | 0.4 | 0.84 | 0.60 | 0.4 | | | | | | | |
| DA-271-004 | M10 | 0.9 | 1.8 | 0.6 | 1.2 | 0.84 | 0.6 | 0.6 | 1.26 | 0.90 | 0.6 | | | | | | | |
| DA-271-006 | M12 | 1.2 | 2.4 | 0.7 | 1.4 | 0.98 | 0.7 | 0.7 | 1.47 | 1.05 | 0.7 | | | | | | | |
| DA-271-013 | M16 | 2.6 | 5.2 | 1.5 | 3.0 | 2.10 | 1.5 | 1.5 | 3.15 | 2.25 | 1.5 | | | | | | | |
| DA-271-020 | M20 | 4.0 | 8.0 | 2.5 | 5.0 | 3.50 | 2.5 | 2.5 | 5.25 | 3.75 | 2.5 | | | | | | | |
| DA-271-035 | M24 | 7.0 | 14.0 | 4.0 | 8.0 | 5.60 | 4.0 | 4.0 | 8.40 | 6.00 | 4.0 | | | | | | | |
| DA-271-060 | M30 | 10.0 | 20.0 | 6.0 | 12.0 | 8.40 | 6.0 | 6.0 | 12.60 | 9.00 | 6.0 | | | | | | | |
| DA-271-080 | M36 | 15.0 | 30.0 | 10.0 | 20.0 | 14.00 | 10.0 | 10.0 | 21.00 | 15.00 | 10.0 | | | | | | | |
| DA-271-120 | M42 | 17.0 | 34.0 | 13.0 | 26.0 | 18.20 | 13.0 | 13.0 | 27.30 | 19.50 | 13.0 | | | | | | | |
| DA-271-130 | M48 | 18.0 | 36.0 | 14.0 | 28.0 | 19.60 | 14.0 | 14.0 | 29.40 | 21.00 | 14.0 | | | | | | | |
| DA-271-140 | M52 | 25.0 | 50.0 | 20.0 | 40.0 | 28.00 | 20.0 | 20.0 | 42.00 | 30.00 | 20.0 | | | | | | | |
| DA-271-160 | M56 | 28.0 | 56.0 | 20.0 | 40.0 | 28.00 | 20.0 | 20.0 | 42.00 | 30.00 | 20.0 | | | | | | | |
| DA-271-161 | M64 | 28.0 | 56.0 | 20.0 | 40.0 | 28.00 | 20.0 | 20.0 | 42.00 | 30.00 | 20.0 | | | | | | | |

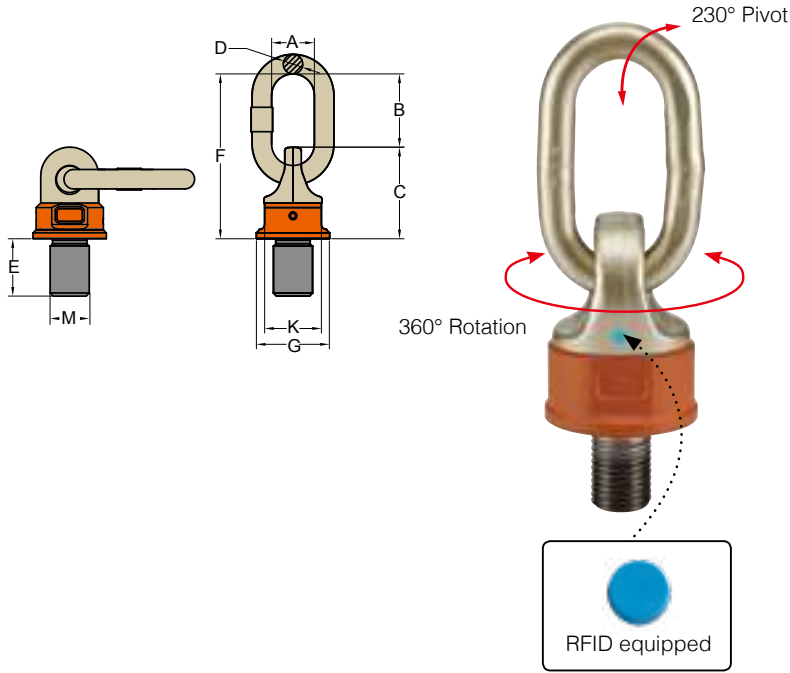

- Pivots to 230°, rotates through 360° due to its unique ball bearing design.
- Manufactured from forged alloy steel, quenched and tempered.
- Tested in accordance with DNV GL-ST-0378.
- Load rated parts are 100% magnaflux crack detected.
- Individual forged parts and batch code links to Test Certificate sheet.
- Bolts are UNC thread.
- Proof tested to 2.5 times the WLL.
- Fatigue rated to 20,000 cycles at 1.5 times the WLL.
- All YOKE Lifting points meet or exceed all the requirements of ASME B30.26.
- Easy to attach or dismantle due to the forged hexagon shaped body of the DA Swivel Point.
- Capable of rotating under load. Do not turn continuously in 90 degree direction at full load.

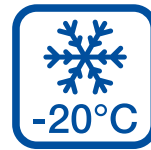

DA Swivel Point

UNC Thread (DA-272)

| Item No. | Working Load Limit | Thread version | | | Dimensions (inch) | | | | | | | | Torque in Nm | N.W. lbs |
|------------|--------------------|----------------|------|--------|-------------------|------|------|------|-------|------|------|------|--------------------|-------------|
| | | M | E | TPI | G | C | K | H | F | D | B | A | | |
| | tonnes | inch | inch | | inch | | | | | | | | | |
| DA-272-006 | 0.7 | 1/2 | 0.75 | 13UNC | 1.57 | 1.77 | 1.42 | 0.71 | 3.74 | 0.39 | 1.97 | 1.38 | 15 | 0.7 |
| DA-272-013 | 1.5 | 5/8 | 0.94 | 11UNC | 1.81 | 2.13 | 1.61 | 0.87 | 4.09 | 0.51 | 1.97 | 1.42 | 45 | 1.2 |
| DA-272-018 | 2.0 | 3/4 | 1.13 | 10UNC | 1.81 | 2.68 | 1.61 | 0.87 | 4.09 | 0.51 | 1.97 | 1.42 | 45 | 1.2 |
| DA-272-020 | 2.5 | 7/8 | 1.31 | 9UNC | 2.44 | 2.68 | 2.17 | 1.14 | 4.80 | 0.51 | 2.13 | 1.42 | 100 | 2.2 |
| DA-272-035 | 4.0 | 1 | 1.50 | 8UNC | 3.07 | 3.46 | 2.76 | 1.42 | 6.06 | 0.75 | 2.60 | 1.61 | 190 | 4.8 |
| DA-272-060 | 6.0 | 1 1/4 | 1.88 | 7UNC | 3.54 | 4.72 | 3.15 | 1.89 | 8.11 | 0.87 | 3.39 | 1.97 | 270 | 9.9 |
| DA-272-080 | 10.0 | 1 1/2 | 2.25 | 6UNC | 3.54 | 4.72 | 3.15 | 1.89 | 8.11 | 0.87 | 3.39 | 1.97 | 270 | 10.0 |
| DA-272-120 | 13.0 | 1 3/4 | 2.63 | 5UNC | 3.86 | 4.80 | 3.31 | 1.97 | 9.25 | 0.98 | 4.33 | 2.64 | 350 | 12.1 |
| DA-272-130 | 14.0 | 2 | 3.00 | 4.5UNC | 3.86 | 4.80 | 3.31 | 1.97 | 9.25 | 0.98 | 4.33 | 2.64 | 350 | 13.5 |
| DA-272-140 | 20.0 | 2 1/4 | 3.38 | 4.5UNC | 4.72 | 5.91 | 3.70 | 2.36 | 10.63 | 1.26 | 4.72 | 2.85 | 350 | 23.1 |
| DA-272-160 | 20.0 | 2 1/2 | 3.75 | 4UNC | 4.72 | 5.91 | 3.70 | 2.36 | 10.63 | 1.26 | 4.72 | 2.85 | 350 | 23.5 |

*Design factor 4:1 proof tested and certified.



| Kind of attachment | | | | | | | | | | | | | | | | |
|--------------------|----------------|----------------|----------------|----------------|----------------|----------------|----------------|----------------|----------------|----------------|----------------|----------------|----------------|----------------|----------------|----------------|
| | Number of legs | Load direction | Number of legs | Load direction | Number of legs | Load direction | Number of legs | Load direction | Number of legs | Load direction | Number of legs | Load direction | Number of legs | Load direction | Number of legs | Load direction |
| Item No. | Thread | WLL(t) | | | | | | | | | | | | | | |
| DA-272-006 | 1/2 | 1.2 | 2.4 | 0.7 | 1.4 | 0.98 | 0.7 | 0.7 | 1.47 | 1.05 | 0.7 | | | | | |
| DA-272-013 | 5/8 | 2.6 | 5.2 | 1.5 | 3.0 | 2.10 | 1.5 | 1.5 | 3.15 | 2.25 | 1.5 | | | | | |
| DA-272-018 | 3/4 | 3.6 | 7.2 | 2.0 | 4.0 | 2.80 | 2.0 | 2.0 | 4.20 | 3.00 | 2.0 | | | | | |
| DA-272-020 | 7/8 | 4.0 | 8.0 | 2.5 | 5.0 | 3.50 | 2.5 | 2.5 | 5.25 | 3.75 | 2.5 | | | | | |
| DA-272-035 | 1 | 7.0 | 14.0 | 4.0 | 8.0 | 5.60 | 4.0 | 4.0 | 8.40 | 6.00 | 4.0 | | | | | |
| DA-272-060 | 1 1/4 | 10.0 | 20.0 | 6.0 | 12.0 | 8.40 | 6.0 | 6.0 | 12.60 | 9.00 | 6.0 | | | | | |
| DA-272-080 | 1 1/2 | 15.0 | 30.0 | 10.0 | 20.0 | 14.00 | 10.0 | 10.0 | 21.00 | 15.00 | 10.0 | | | | | |
| DA-272-120 | 1 3/4 | 17.0 | 34.0 | 13.0 | 26.0 | 18.20 | 13.0 | 13.0 | 27.30 | 19.50 | 13.0 | | | | | |
| DA-272-130 | 2 | 18.0 | 36.0 | 14.0 | 28.0 | 19.60 | 14.0 | 14.0 | 29.40 | 21.00 | 14.0 | | | | | |
| DA-272-140 | 2 1/4 | 25.0 | 50.0 | 20.0 | 40.0 | 28.00 | 20.0 | 20.0 | 42.00 | 30.00 | 20.0 | | | | | |
| DA-272-160 | 2 1/2 | 28.0 | 56.0 | 20.0 | 40.0 | 28.00 | 20.0 | 20.0 | 42.00 | 30.00 | 20.0 | | | | | |

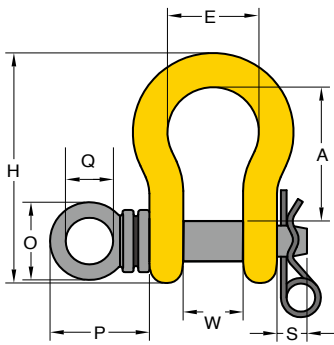

- ROV: Remotely Operated Vehicle
- Forged alloy steel, quenched and tempered.
 - Designed specifically for ROV application.
 - Individually stamped with the Working Load Limit.
 - Shackle Bows are painted yellow to ensure ease of sight in water.

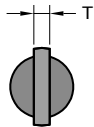

**ROV Anchor Shackle
with Safety Pin
(ROV: Remotely Operated Vehicle)**

| Item No. | Nominal Size | | Working Load Limit tonnes* | Dimensions (inch) | | | | | | | | | N.W. lbs |
|----------|--------------|----|-------------------------------|-------------------|------|-------|------|------|------|------|------|------|-------------|
| | inch | mm | | A | E | H | O | P | Q | S | T | W | |
| 8-911-22 | 7/8 | 22 | 6.5 | 3.39 | 2.28 | 5.91 | 1.96 | 2.36 | 1.18 | 0.87 | 0.39 | 1.50 | 4.0 |
| 8-911-26 | 1 | 26 | 8.5 | 3.78 | 2.68 | 6.57 | 1.96 | 2.48 | 1.18 | 0.91 | 0.39 | 1.73 | 5.5 |
| 8-911-28 | 1 1/8 | 28 | 9.5 | 4.37 | 2.91 | 7.52 | 2.75 | 3.35 | 1.38 | 0.94 | 0.47 | 1.81 | 7.9 |
| 8-911-32 | 1 1/4 | 32 | 12.0 | 4.76 | 3.30 | 8.07 | 2.75 | 3.35 | 1.38 | 1.14 | 0.47 | 2.12 | 10.6 |
| 8-911-36 | 1 3/8 | 36 | 13.5 | 5.28 | 3.62 | 9.13 | 2.95 | 3.66 | 1.57 | 1.22 | 0.59 | 2.32 | 15.0 |
| 8-911-38 | 1 1/2 | 38 | 17.0 | 5.75 | 3.90 | 10.00 | 2.95 | 3.74 | 1.57 | 1.22 | 0.59 | 2.36 | 18.3 |
| 8-911-45 | 1 3/4 | 45 | 25.0 | 7.00 | 5.00 | 12.32 | 3.54 | 4.48 | 1.97 | 1.38 | 0.71 | 2.87 | 36.5 |
| 8-911-50 | 2 | 50 | 35.0 | 7.76 | 5.75 | 13.66 | 4.17 | 5.19 | 2.36 | 1.57 | 0.78 | 3.27 | 51.5 |

★ Minimum Ultimate Load is 5 times the Working Load Limit.
Maximum Proof Load is 2 times the Working Load Limit.

| Item No. | Nominal Size | | Working Load Limit tonnes* | Dimensions (mm) | | | | | | | | | N.W. kg |
|----------|--------------|----|-------------------------------|-----------------|-----|-----|-----|-----|----|----|----|----|------------|
| | inch | mm | | A | E | H | O | P | Q | S | T | W | |
| 8-911-22 | 7/8 | 22 | 6.5 | 86 | 58 | 148 | 50 | 60 | 30 | 22 | 10 | 38 | 1.8 |
| 8-911-26 | 1 | 26 | 8.5 | 96 | 69 | 166 | 50 | 63 | 30 | 23 | 10 | 44 | 2.5 |
| 8-911-28 | 1 1/8 | 28 | 9.5 | 111 | 74 | 190 | 70 | 85 | 35 | 24 | 12 | 46 | 3.6 |
| 8-911-32 | 1 1/4 | 32 | 12.0 | 121 | 84 | 210 | 70 | 85 | 35 | 29 | 12 | 54 | 4.8 |
| 8-911-36 | 1 3/8 | 36 | 13.5 | 134 | 92 | 232 | 75 | 93 | 40 | 31 | 15 | 59 | 6.8 |
| 8-911-38 | 1 1/2 | 38 | 17.0 | 146 | 99 | 254 | 75 | 95 | 40 | 31 | 15 | 60 | 8.3 |
| 8-911-45 | 1 3/4 | 45 | 25.0 | 178 | 127 | 313 | 90 | 114 | 50 | 35 | 18 | 73 | 16.6 |
| 8-911-50 | 2 | 50 | 35.0 | 197 | 146 | 347 | 106 | 132 | 60 | 40 | 20 | 83 | 23.4 |

★ Minimum Ultimate Load is 5 times the Working Load Limit.
Maximum Proof Load is 2 times the Working Load Limit.

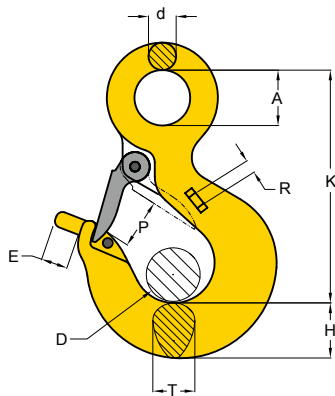

ROV: Remotely Operated Vehicle

- Forged alloy steel, quenched and tempered.
- Designed specifically for ROV application.
- Individually stamped with the Working Load Limit.
- Shackle Bows are painted yellow to ensure ease of sight in water.

ROV Eye Sling Hook (ROV: Remotely Operated Vehicle)

| Item No. | Working Load Limit | Dimensions (inch) | | | | | | | | | N.W. |
|----------|--------------------|-------------------|------|------|------|------|-------|------|------|------|------|
| | tonnes* | A | D | d | E | H | K | P | R | T | lbs |
| 8-921-03 | 3.0 | 1.26 | 0.98 | 0.59 | 0.78 | 1.14 | 4.80 | 0.98 | 0.31 | 0.95 | 2.2 |
| 8-921-05 | 5.0 | 1.57 | 1.22 | 0.71 | 0.78 | 1.46 | 5.87 | 1.22 | 0.31 | 1.22 | 4.6 |
| 8-921-07 | 7.0 | 2.00 | 1.54 | 0.95 | 0.78 | 1.89 | 7.56 | 1.54 | 0.31 | 1.42 | 8.8 |
| 8-921-11 | 11.0 | 2.48 | 2.24 | 1.10 | 1.18 | 2.20 | 9.13 | 2.24 | 0.31 | 1.85 | 15.4 |
| 8-921-15 | 15.0 | 2.84 | 2.44 | 1.30 | 1.18 | 2.52 | 10.24 | 2.44 | 0.31 | 2.05 | 20.7 |
| 8-921-22 | 22.0 | 3.58 | 3.19 | 1.57 | 1.96 | 2.91 | 12.50 | 3.19 | 0.39 | 2.68 | 40.9 |
| 8-921-30 | 30.0 | 3.58 | 3.27 | 1.77 | 1.96 | 3.62 | 13.66 | 3.27 | 0.39 | 2.99 | 68.6 |

★ Minimum Ultimate Load is 4 times the Working Load Limit.
Maximum Proof Load is 2 times the Working Load Limit.

| Item No. | Working Load Limit | Dimensions (mm) | | | | | | | | | N.W. |
|----------|--------------------|-----------------|----|----|----|----|-----|----|----|----|------|
| | tonnes | A | D | d | E | H | K | P | R | T | kg |
| 8-921-03 | 3.0 | 32 | 25 | 15 | 20 | 29 | 122 | 25 | 8 | 24 | 1.0 |
| 8-921-05 | 5.0 | 40 | 31 | 18 | 20 | 37 | 149 | 31 | 8 | 31 | 2.1 |
| 8-921-07 | 7.0 | 51 | 39 | 24 | 20 | 48 | 192 | 39 | 8 | 36 | 4.0 |
| 8-921-11 | 11.0 | 63 | 57 | 28 | 30 | 56 | 232 | 57 | 8 | 47 | 7.0 |
| 8-921-15 | 15.0 | 72 | 62 | 33 | 30 | 64 | 260 | 62 | 8 | 52 | 9.4 |
| 8-921-22 | 22.0 | 91 | 81 | 40 | 50 | 74 | 318 | 81 | 10 | 68 | 18.6 |
| 8-921-30 | 30.0 | 91 | 83 | 45 | 50 | 92 | 347 | 83 | 10 | 76 | 31.2 |

★ Minimum Ultimate Load is 4 times the Working Load Limit.
Maximum Proof Load is 2 times the Working Load Limit.

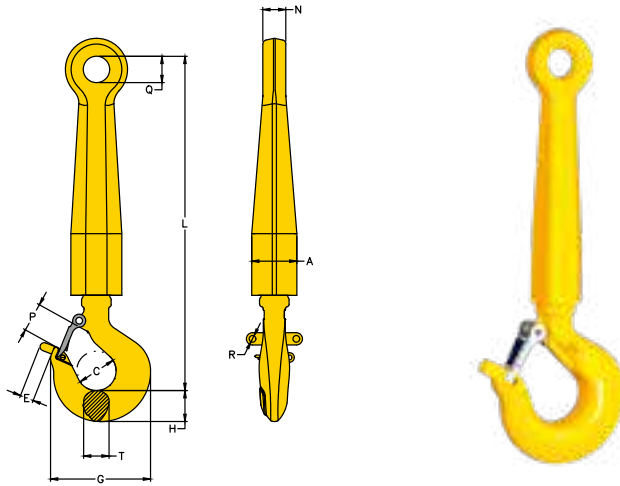

ROV: Remotely Operated Vehicle

- Forged alloy steel, quenched and tempered.
- Designed specifically for ROV application.
- Individually stamped with the Working Load Limit.
- Shackle Bows are painted yellow to ensure ease of sight in water.

ROV Shank Hook (ROV: Remotely Operated Vehicle)

| Item No. | Working Load Limit | Dimensions (inch) | | | | | | | | | | | N.W. |
|----------|--------------------|-------------------|------|------|-------|------|-------|------|------|------|------|------|------|
| | tonnes* | A | C | E | G | H | L | N | P | Q | R | T | lbs |
| 8-931-05 | 5.4 | 2.16 | 1.53 | 0.78 | 5.12 | 1.46 | 16.02 | 1.10 | 1.26 | 1.25 | 0.31 | 1.31 | 13.2 |
| 8-931-08 | 8.0 | 2.16 | 1.94 | 0.78 | 6.54 | 1.82 | 16.97 | 1.10 | 1.54 | 1.25 | 0.31 | 1.66 | 16.7 |
| 8-931-11 | 11.5 | 2.56 | 2.46 | 1.18 | 7.72 | 2.28 | 19.17 | 1.57 | 2.24 | 1.96 | 0.31 | 1.88 | 30.6 |
| 8-931-16 | 16.0 | 2.56 | 2.59 | 1.18 | 8.70 | 2.60 | 19.41 | 1.57 | 2.44 | 1.96 | 0.31 | 2.19 | 35.0 |
| 8-931-22 | 22.0 | 3.35 | 2.81 | 1.96 | 10.91 | 3.01 | 22.24 | 2.04 | 3.19 | 2.55 | 0.39 | 2.69 | 68.2 |
| 8-931-32 | 31.5 | 3.35 | 3.44 | 1.96 | 13.90 | 3.62 | 23.41 | 2.04 | 3.46 | 2.55 | 0.39 | 3.00 | 98.1 |

★ Minimum Ultimate Load is 4 times the Working Load Limit.
Maximum Proof Load is 2 times the Working Load Limit.

| Item No. | Working Load Limit | Dimensions (mm) | | | | | | | | | | | N.W. |
|----------|--------------------|-----------------|----|----|-----|----|-----|----|----|----|----|----|------|
| | tonnes* | A | C | E | G | H | L | N | P | Q | R | T | kg |
| 8-931-05 | 5.4 | 55 | 38 | 20 | 130 | 37 | 407 | 28 | 32 | 32 | 8 | 33 | 6.0 |
| 8-931-08 | 8.0 | 55 | 49 | 20 | 166 | 46 | 431 | 28 | 39 | 32 | 8 | 42 | 7.6 |
| 8-931-11 | 11.5 | 65 | 62 | 30 | 196 | 58 | 487 | 40 | 57 | 50 | 8 | 48 | 13.9 |
| 8-931-16 | 16.0 | 65 | 65 | 30 | 221 | 66 | 493 | 40 | 62 | 50 | 8 | 56 | 15.9 |
| 8-931-22 | 22.0 | 85 | 71 | 50 | 277 | 77 | 565 | 52 | 81 | 65 | 10 | 68 | 31.0 |
| 8-931-32 | 31.5 | 85 | 87 | 50 | 353 | 92 | 596 | 52 | 88 | 65 | 10 | 76 | 44.6 |

★ Minimum Ultimate Load is 4 times the Working Load Limit.
Maximum Proof Load is 2 times the Working Load Limit.



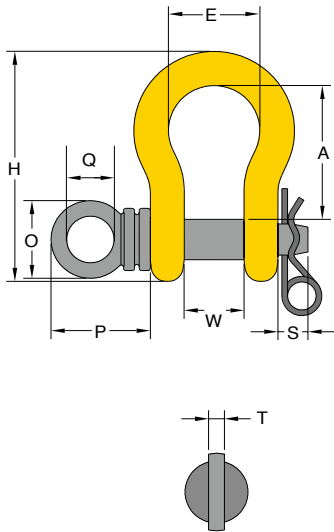

ROV: Remotely Operated Vehicle

- Forged alloy steel, quenched and tempered.
- Designed specifically for ROV application.
- Individually stamped with the Working Load Limit.
- Painted yellow for high visibility subsea.

**ROV Anchor Shackle
with Safety Pin
(ROV: Remotely Operated Vehicle)**

| Item No. | Nominal Size | | Working Load Limit tonnes* | Dimensions (inch) | | | | | | | | | N.W. lbs |
|----------|--------------|----|-------------------------------|-------------------|------|-------|------|------|------|------|------|------|-------------|
| | inch | mm | | A | E | H | O | P | Q | S | T | W | |
| 8-911-22 | 7/8 | 22 | 6.5 | 3.39 | 2.28 | 5.91 | 1.96 | 2.48 | 1.18 | 0.74 | 0.39 | 1.50 | 4.0 |
| 8-911-26 | 1 | 26 | 8.5 | 3.78 | 2.68 | 6.57 | 1.96 | 2.55 | 1.18 | 0.78 | 0.39 | 1.73 | 5.5 |
| 8-911-28 | 1 1/8 | 28 | 9.5 | 4.37 | 2.91 | 7.52 | 2.75 | 3.46 | 1.38 | 0.82 | 0.47 | 1.81 | 7.9 |
| 8-911-32 | 1 1/4 | 32 | 12.0 | 4.76 | 3.30 | 8.07 | 2.75 | 3.46 | 1.38 | 0.98 | 0.47 | 2.12 | 10.6 |
| 8-911-36 | 1 3/8 | 36 | 13.5 | 5.28 | 3.62 | 9.13 | 2.95 | 3.77 | 1.57 | 1.06 | 0.59 | 2.32 | 15.0 |
| 8-911-38 | 1 1/2 | 38 | 17.0 | 5.75 | 3.90 | 10.00 | 2.95 | 3.85 | 1.57 | 1.06 | 0.59 | 2.36 | 18.3 |
| 8-911-45 | 1 3/4 | 45 | 25.0 | 7.00 | 5.00 | 12.32 | 3.54 | 4.48 | 1.97 | 1.18 | 0.78 | 2.87 | 36.5 |
| 8-911-50 | 2 | 50 | 35.0 | 7.76 | 5.75 | 13.66 | 4.17 | 5.19 | 2.36 | 1.18 | 0.78 | 3.27 | 51.5 |

★ Minimum Ultimate Load is 5 times the Working Load Limit.
Maximum Proof Load is 2 times the Working Load Limit.

| Item No. | Nominal Size | | Working Load Limit tonnes* | Dimensions (mm) | | | | | | | | | N.W. kg |
|----------|--------------|----|-------------------------------|-----------------|-----|-----|-----|-----|----|----|----|----|------------|
| | inch | mm | | A | E | H | O | P | Q | S | T | W | |
| 8-911-22 | 7/8 | 22 | 6.5 | 86 | 58 | 148 | 50 | 63 | 30 | 19 | 10 | 38 | 1.8 |
| 8-911-26 | 1 | 26 | 8.5 | 96 | 69 | 166 | 50 | 65 | 30 | 20 | 10 | 44 | 2.5 |
| 8-911-28 | 1 1/8 | 28 | 9.5 | 111 | 74 | 190 | 70 | 88 | 35 | 21 | 12 | 46 | 3.6 |
| 8-911-32 | 1 1/4 | 32 | 12.0 | 121 | 84 | 210 | 70 | 88 | 35 | 25 | 12 | 54 | 4.8 |
| 8-911-36 | 1 3/8 | 36 | 13.5 | 134 | 92 | 232 | 75 | 96 | 40 | 27 | 15 | 59 | 6.8 |
| 8-911-38 | 1 1/2 | 38 | 17.0 | 146 | 99 | 254 | 75 | 98 | 40 | 27 | 15 | 60 | 8.3 |
| 8-911-45 | 1 3/4 | 45 | 25.0 | 178 | 127 | 313 | 90 | 114 | 50 | 30 | 20 | 73 | 16.6 |
| 8-911-50 | 2 | 50 | 35.0 | 197 | 146 | 347 | 106 | 132 | 60 | 30 | 20 | 83 | 23.4 |

★ Minimum Ultimate Load is 5 times the Working Load Limit.
Maximum Proof Load is 2 times the Working Load Limit.

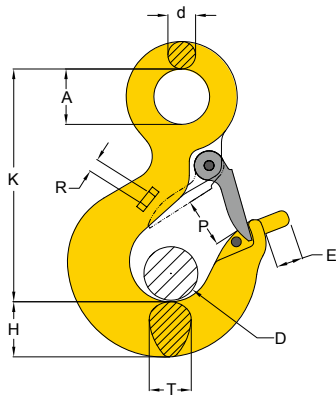

ROV: Remotely Operated Vehicle

- Forged alloy steel, quenched and tempered.
- Designed specifically for ROV application.
- Individually stamped with the Working Load Limit.
- Painted yellow for high visibility subsea.

ROV Eye Sling Hook (ROV: Remotely Operated Vehicle)

| Item No. | Working Load Limit | Dimensions (inch) | | | | | | | | | N.W. |
|----------|--------------------|-------------------|------|------|------|------|-------|------|------|------|------|
| | tonnes* | A | D | d | E | H | K | P | R | T | lbs |
| 8-921-03 | 3.0 | 1.26 | 0.98 | 0.59 | 0.78 | 1.14 | 4.80 | 0.98 | 0.31 | 0.95 | 2.2 |
| 8-921-05 | 5.0 | 1.57 | 1.22 | 0.71 | 0.78 | 1.46 | 5.87 | 1.22 | 0.31 | 1.22 | 4.6 |
| 8-921-07 | 7.0 | 2.00 | 1.54 | 0.95 | 0.78 | 1.82 | 7.56 | 1.54 | 0.31 | 1.46 | 8.8 |
| 8-921-11 | 11.0 | 2.44 | 2.24 | 1.10 | 1.18 | 2.28 | 9.13 | 2.24 | 0.31 | 1.89 | 15.4 |
| 8-921-15 | 15.0 | 2.84 | 2.44 | 1.26 | 1.18 | 2.60 | 10.10 | 2.44 | 0.31 | 2.20 | 20.7 |
| 8-921-22 | 22.0 | 3.54 | 3.19 | 1.57 | 1.96 | 3.01 | 12.50 | 3.19 | 0.39 | 2.68 | 40.9 |
| 8-921-30 | 30.0 | 3.54 | 3.27 | 1.77 | 1.96 | 3.62 | 14.10 | 3.27 | 0.39 | 2.99 | 68.6 |

★ Minimum Ultimate Load is 4 times the Working Load Limit.
Maximum Proof Load is 2 times the Working Load Limit.

| Item No. | Working Load Limit | Dimensions (mm) | | | | | | | | | N.W. |
|----------|--------------------|-----------------|----|----|----|----|-----|----|----|----|------|
| | tonnes | A | D | d | E | H | K | P | R | T | kg |
| 8-921-03 | 3.0 | 32 | 25 | 15 | 20 | 29 | 122 | 25 | 8 | 24 | 1.0 |
| 8-921-05 | 5.0 | 40 | 31 | 18 | 20 | 37 | 149 | 31 | 8 | 31 | 2.1 |
| 8-921-07 | 7.0 | 51 | 39 | 24 | 20 | 46 | 192 | 39 | 8 | 37 | 4.0 |
| 8-921-11 | 11.0 | 62 | 57 | 28 | 30 | 58 | 232 | 57 | 8 | 48 | 7.0 |
| 8-921-15 | 15.0 | 72 | 62 | 32 | 30 | 66 | 256 | 62 | 8 | 56 | 9.4 |
| 8-921-22 | 22.0 | 90 | 81 | 40 | 50 | 77 | 318 | 81 | 10 | 68 | 18.6 |
| 8-921-30 | 30.0 | 90 | 83 | 45 | 50 | 92 | 357 | 83 | 10 | 76 | 31.2 |

★ Minimum Ultimate Load is 4 times the Working Load Limit.
Maximum Proof Load is 2 times the Working Load Limit.

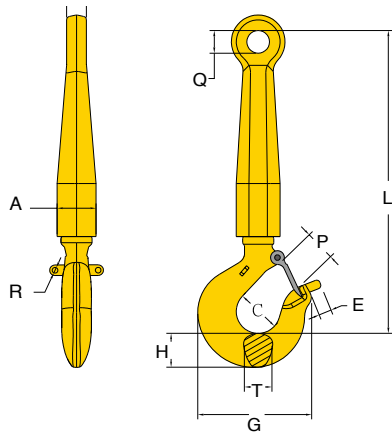

ROV: Remotely Operated Vehicle

- Forged alloy steel, quenched and tempered.
- Designed specifically for ROV application.
- Individually stamped with the Working Load Limit.
- Painted yellow for high visibility subsea.

ROV Shank Hook (ROV: Remotely Operated Vehicle)

| Item No. | Working Load Limit tonnes* | Dimensions (inch) | | | | | | | | | | | N.W. lbs |
|----------|-------------------------------|-------------------|------|------|-------|------|-------|------|------|------|------|------|-------------|
| | | A | C | E | G | H | L | N | P | Q | R | T | |
| 8-931-05 | 5.4 | 2.16 | 1.53 | 0.78 | 5.12 | 1.46 | 15.90 | 1.10 | 1.26 | 1.25 | 0.31 | 1.31 | 13.2 |
| 8-931-08 | 8.0 | 2.16 | 1.94 | 0.78 | 6.54 | 1.82 | 16.81 | 1.10 | 1.54 | 1.25 | 0.31 | 1.66 | 16.7 |
| 8-931-11 | 11.5 | 2.56 | 2.46 | 1.18 | 7.72 | 2.28 | 22.40 | 1.57 | 2.24 | 1.96 | 0.31 | 1.88 | 30.6 |
| 8-931-16 | 16.0 | 2.56 | 2.59 | 1.18 | 8.70 | 2.60 | 23.07 | 1.57 | 2.44 | 1.96 | 0.31 | 2.19 | 35.0 |
| 8-931-22 | 22.0 | 3.35 | 2.81 | 1.96 | 10.91 | 3.01 | 26.96 | 2.04 | 3.19 | 2.55 | 0.39 | 2.69 | 68.2 |
| 8-931-32 | 31.5 | 3.35 | 3.44 | 1.96 | 13.90 | 3.62 | 28.66 | 2.04 | 3.46 | 2.55 | 0.39 | 3.00 | 98.1 |

★ Minimum Ultimate Load is 4 times the Working Load Limit.
Maximum Proof Load is 2 times the Working Load Limit.

| Item No. | Working Load Limit tonnes* | Dimensions (mm) | | | | | | | | | | | N.W. kg |
|----------|-------------------------------|-----------------|----|----|-----|----|-----|----|----|----|----|----|------------|
| | | A | C | E | G | H | L | N | P | Q | R | T | |
| 8-931-05 | 5.4 | 55 | 38 | 20 | 130 | 37 | 404 | 28 | 32 | 32 | 8 | 33 | 6.0 |
| 8-931-08 | 8.0 | 55 | 49 | 20 | 166 | 46 | 427 | 28 | 39 | 32 | 8 | 42 | 7.6 |
| 8-931-11 | 11.5 | 65 | 62 | 30 | 196 | 58 | 569 | 40 | 57 | 50 | 8 | 48 | 13.9 |
| 8-931-16 | 16.0 | 65 | 65 | 30 | 221 | 66 | 586 | 40 | 62 | 50 | 8 | 56 | 15.9 |
| 8-931-22 | 22.0 | 85 | 71 | 50 | 277 | 77 | 685 | 52 | 81 | 65 | 10 | 68 | 31.0 |
| 8-931-32 | 31.5 | 85 | 87 | 50 | 353 | 92 | 728 | 52 | 88 | 65 | 10 | 76 | 44.6 |

★ Minimum Ultimate Load is 4 times the Working Load Limit.
Maximum Proof Load is 2 times the Working Load Limit.



Quick index of YOKE Snatch Block & Trawl Block

Light Snatch Block



Forged Snatch Block



Super Snatch Block



Alloy Snatch Block

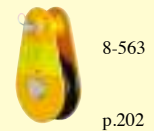
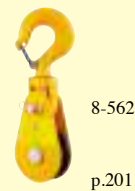

Alloy HC Snatch Block

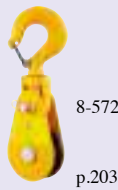

Oilfield Block





Superior Design Features of YOKE Snatch Blocks

- ✓ YSB sheaves are closed die drop forged steel. Available in size from 3" to 12" satisfying your heavy duty applications.
- ✓ Groove bottom hardened to 35 Rc maximizes durability of Snatch Blocks.

Quality Management System:







8-501-02
8-501-04



8-501-08 and up

- YOKE Light Snatch Blocks are manufactured of the highest quality tensile steel.
- Available from 2 tonnes to 8 tonnes, for wire rope sizes 8mm to 19mm.
- Part number, wire rope size and working load limit are marked on each block.
- Permanent batch codes link to test certificates for easy traceability.
- Supplied with bronze bushings and 4.5"-14" with pressure lube fittings.
- Meets or exceeds all requirements of ASME B30.26.
- Safety factor 4:1
- Fatigue rated



✓ Sheave by Closed Die Forged Steel

Light Snatch Block with Shackle

| Item No. | Sheave Dia. | Bearing Type | Wire Rope Size | Working Load Limit | N.W. | |
|------------------|-------------|--------------|----------------|--------------------|------|----|
| | inch | | mm | t* | lbs | kg |
| 8-501-02 | 3 | BB | 8-10 | 2 | 4 | 2 |
| 8-501-04 | 4.5 | BB | 10-13 | 4 | 13 | 6 |
| 8-501-08 | 6 | BB | 16-19 | 8 | 29 | 13 |
| 8-501-0808 | 8 | BB | 16-19 | 8 | 44 | 20 |
| 8-501-0810 | 10 | BB | 16-19 | 8 | 46 | 21 |
| ** 8-501-0812-16 | 12 | BB | 16 | 8 | 49 | 22 |
| ** 8-501-0812-19 | 12 | BB | 19 | 8 | 49 | 22 |
| ** 8-501-0814-16 | 14 | BB | 16 | 8 | 56 | 25 |
| ** 8-501-0814-19 | 14 | BB | 19 | 8 | 56 | 25 |

*Minimum Ultimate Load is 4 times the Working Load Limit.

**Available from August, 2015



- YOKE Light Snatch Blocks are manufactured of the highest quality tensile steel.
- Available from 2 tonnes to 8 tonnes, for wire rope sizes 8mm to 19mm.
- Part number, wire rope size and working load limit are marked on each block.
- Permanent batch codes link to test certificates for easy traceability.
- Supplied with bronze bushings and 4.5"-14" with pressure lube fittings.
- Meets or exceeds all requirements of ASME B30.26.
- Safety factor 4:1
- Fatigue rated



✓ Sheave by Closed Die Forged Steel

Light Snatch Block with Hook

| Item No. | Sheave Dia. | Bearing Type | Wire Rope Size | Working Load Limit | N.W. | |
|------------------|-------------|--------------|----------------|--------------------|------|----|
| | inch | | mm | t* | lbs | kg |
| 8-502-02 | 3 | BB | 8-10 | 2 | 7 | 3 |
| 8-502-04 | 4.5 | BB | 10-13 | 4 | 13 | 6 |
| 8-502-08 | 6 | BB | 16-19 | 8 | 29 | 13 |
| 8-502-0808 | 8 | BB | 16-19 | 8 | 42 | 19 |
| 8-502-0810 | 10 | BB | 16-19 | 8 | 45 | 21 |
| 8-502-0812-16 | 12 | BB | 16 | 8 | 48 | 22 |
| 8-502-0812-19 | 12 | BB | 19 | 8 | 48 | 22 |
| ** 8-502-0814-16 | 14 | BB | 16 | 8 | 55 | 25 |
| ** 8-502-0814-19 | 14 | BB | 19 | 8 | 55 | 25 |

*Minimum Ultimate Load is 4 times the Working Load Limit.

**Available from August, 2015



- YOKE Forged Snatch Blocks are manufactured of the highest quality forged alloy steel.
- Available from 12 tonnes to 15 tonnes, for wire rope sizes 19mm to 22mm.
- Part number, wire rope size and working load limit are marked on each block.
- Permanent batch codes link to test certificates for easy traceability.
- Supplied with bronze bushings and pressure lube fittings.
- Meets or exceeds all requirements of ASME B30.26.
- Safety factor 4:1
- Fatigue rated



✓ Sheave by Closed Die Forged Steel

Forged Snatch Block with Shackle

| Item No. | Sheave Dia. | Bearing Type | Wire Rope Size | Working Load Limit | N.W. | |
|------------|-------------|--------------|----------------|--------------------|------|----|
| | inch | | mm | t* | lbs | kg |
| 8-541-12 | 6 | BB | 19-22 | 12 | 52 | 24 |
| 8-541-15 | 8 | BB | 19-22 | 15 | 61 | 28 |
| 8-541-1510 | 10 | BB | 19-22 | 15 | 90 | 41 |

*Minimum Ultimate Load is 4 times the Working Load Limit.



- YOKE Forged Snatch Blocks are manufactured of the highest quality forged alloy steel.
- Available from 12 tonnes to 15 tonnes, for wire rope sizes 19mm to 22mm.
- Part number, wire rope size and working load limit are marked on each block.
- Permanent batch codes link to test certificates for easy traceability.
- Supplied with bronze bushings and pressure lube fittings.
- Meets or exceeds all requirements of ASME B30.26.
- Safety factor 4:1
- Fatigue rated



✓ Sheave by Closed Die Forged Steel

Forged Snatch Block with Hook

| Item No. | Sheave Dia. | Bearing Type | Wire Rope Size | Working Load Limit | N.W. | |
|------------|-------------|--------------|----------------|--------------------|------|----|
| | inch | | mm | t* | lbs | kg |
| 8-542-12 | 6 | BB | 19-22 | 12 | 48 | 22 |
| 8-542-15 | 8 | BB | 19-22 | 15 | 64 | 29 |
| 8-542-1510 | 10 | BB | 19-22 | 15 | 92 | 42 |

*Minimum Ultimate Load is 4 times the Working Load Limit.



- YOKE Super Snatch Blocks are manufactured of the highest quality tensile steel.
- Available from 20 tonnes to 30 tonnes, for wire rope sizes 25mm to 32mm.
- Part number, wire rope size and working load limit are marked on each block.
- Permanent batch codes link to test certificates for easy traceability.
- Supplied with bronze bushings and pressure lube fittings.
- Meets or exceeds all requirements of ASME B30.26.
- Safety factor 4:1
- Fatigue rated



✓ Sheave by Closed Die Forged Steel

Super Snatch Block with Shackle

| Item No. | Sheave Dia. | Bearing Type | Wire Rope Size | Working Load Limit | N.W. | |
|------------------|-------------|--------------|----------------|--------------------|------|-----|
| | inch | | mm | t* | lbs | kg |
| 8-551-20 | 8 | BB | 25-29 | 20 | 92 | 42 |
| 8-551-2010 | 10 | BB | 25-29 | 20 | 119 | 54 |
| 8-551-2012-25 | 12 | BB | 25 | 20 | 139 | 63 |
| 8-551-2012-29 | 12 | BB | 29 | 20 | 139 | 63 |
| ** 8-551-2015-29 | 14 | BB | 29 | 20 | 150 | 68 |
| ** 8-551-2518-25 | 18 | BB | 25 | 25 | 260 | 118 |
| ** 8-551-2518-29 | 18 | BB | 29 | 25 | 260 | 118 |
| ** 8-551-3020-29 | 20 | BB | 29 | 30 | 398 | 181 |
| ** 8-551-3020-32 | 20 | BB | 32 | 30 | 400 | 182 |
| ** 8-551-3024-29 | 24 | BB | 29 | 30 | 475 | 216 |
| ** 8-551-3024-32 | 24 | BB | 32 | 30 | 475 | 216 |

* Minimum Ultimate Load is 4 times the Working Load Limit.

** Available from August, 2015



- YOKE Super Snatch Blocks are manufactured of the highest quality tensile steel.
- Available from 20 tonnes to 30 tonnes, for wire rope sizes 25mm to 32mm.
- Part number, wire rope size and working load limit are marked on each block.
- Permanent batch codes link to test certificates for easy traceability.
- Supplied with bronze bushings and pressure lube fittings.
- Meets or exceeds all requirements of ASME B30.26.
- Safety factor 4:1
- Fatigue rated



✓ Sheave by Closed Die Forged Steel

Super Snatch Block with Hook

| Item No. | Sheave Dia. | Bearing Type | Wire Rope Size | Working Load Limit | N.W. | |
|------------------|-------------|--------------|----------------|--------------------|------|-----|
| | inch | | mm | t* | lbs | kg |
| 8-552-20 | 8 | BB | 25-29 | 20 | 90 | 41 |
| 8-552-2010 | 10 | BB | 25-29 | 20 | 117 | 53 |
| 8-552-2012-25 | 12 | BB | 25 | 20 | 139 | 63 |
| 8-552-2012-29 | 12 | BB | 29 | 20 | 139 | 63 |
| ** 8-552-2015-29 | 14 | BB | 29 | 20 | 154 | 70 |
| ** 8-552-2518-25 | 18 | BB | 25 | 25 | 240 | 109 |
| ** 8-552-2518-29 | 18 | BB | 29 | 25 | 240 | 109 |
| ** 8-552-3020-29 | 20 | BB | 29 | 30 | 375 | 171 |
| ** 8-552-3020-32 | 20 | BB | 32 | 30 | 375 | 171 |
| ** 8-552-3024-29 | 24 | BB | 29 | 30 | 450 | 205 |
| ** 8-552-3024-32 | 24 | BB | 32 | 30 | 450 | 205 |

* Minimum Ultimate Load is 4 times the Working Load Limit.

** Available from August, 2015



- YOKE Alloy Snatch Blocks are manufactured of the highest quality alloy steel.
- Available in 12 tonnes, for wire rope sizes 19mm to 22mm.
- Part number, wire rope size and working load limit are marked on each block.
- Permanent batch codes link to test certificates for easy traceability.
- Supplied with bronze bushings and pressure lube fittings.
- Meets or exceeds all requirements of ASME B30.26.
- Safety factor 4:1
- Fatigue rated



✓ Sheave by Closed Die Forged Steel

Alloy Snatch Block with Shackle

| Item No. | Sheave Dia. | Bearing Type | Wire Rope Size | Working Load Limit | N.W. | |
|------------|-------------|--------------|----------------|--------------------|------|----|
| | inch | | mm | t* | lbs | kg |
| 8-561-12 | 6 | BB | 19-22 | 12 | 28 | 13 |
| 8-561-1208 | 8 | BB | 19-22 | 12 | 37 | 17 |
| 8-561-1210 | 10 | BB | 19-22 | 12 | 46 | 21 |

*Minimum Ultimate Load is 4 times the Working Load Limit.



- YOKE Alloy Snatch Blocks are manufactured of the highest quality alloy steel.
- Available in 12 tonnes, for wire rope sizes 19mm to 22mm.
- Part number, wire rope size and working load limit are marked on each block.
- Permanent batch codes link to test certificates for easy traceability.
- Supplied with bronze bushings and pressure lube fittings.
- Meets or exceeds all requirements of ASME B30.26.
- Safety factor 4:1
- Fatigue rated



✓ Sheave by Closed Die Forged Steel

Alloy Snatch Block with Hook

| Item No. | Sheave Dia. | Bearing Type | Wire Rope Size | Working Load Limit | N.W. | |
|------------|-------------|--------------|----------------|--------------------|------|----|
| | inch | | mm | t* | lbs | kg |
| 8-562-12 | 6 | BB | 19-22 | 12 | 31 | 14 |
| 8-562-1208 | 8 | BB | 19-22 | 12 | 37 | 17 |
| 8-562-1210 | 10 | BB | 19-22 | 12 | 46 | 21 |

*Minimum Ultimate Load is 4 times the Working Load Limit.



- YOKE Alloy HC Snatch Blocks are manufactured of the highest quality alloy steel.
- Available from 25 tonnes to 30 tonnes, for wire rope sizes 25mm to 32mm.
- Part number, wire rope size and working load limit are marked on each block.
- Permanent batch codes link to test certificates for easy traceability.
- Supplied with bronze bushings and pressure lube fittings.
- Meets or exceeds all requirements of ASME B30.26.
- Safety factor 4:1
- Fatigue rated



✓ Sheave by Closed Die Forged Steel

Alloy HC Snatch Block with Hook

| Item No. | Sheave Dia. | Bearing Type | Wire Rope Size | Working Load Limit | N.W. | |
|------------------|-------------|--------------|----------------|--------------------|------|----|
| | inch | | mm | t* | lbs | kg |
| 8-572-2508-25 | 8 | BB | 25 | 25 | 90 | 41 |
| 8-572-2508-29 | 8 | BB | 29 | 25 | 90 | 41 |
| 8-572-2510-25 | 10 | BB | 25 | 25 | 107 | 49 |
| 8-572-2510-29 | 10 | BB | 29 | 25 | 107 | 49 |
| 8-572-2510-32 | 10 | BB | 32 | 25 | 107 | 49 |
| 8-572-3012-25 | 12 | BB | 25 | 30 | 165 | 75 |
| 8-572-3012-29 | 12 | BB | 29 | 30 | 165 | 75 |
| ** 8-572-3014-25 | 14 | BB | 25 | 30 | 180 | 82 |
| ** 8-572-3014-29 | 14 | BB | 29 | 30 | 180 | 82 |

* Minimum Ultimate Load is 4 times the Working Load Limit.

** Available from August, 2015



- YOKE Oilfield Hoist Blocks are manufactured of the highest quality alloy steel.
- Available from 4 tonnes to 30 tonnes for wire rope sizes 8mm to 20mm.
- Part number, wire rope size and working load limit are marked on each block.
- Permanent batch codes link to test certificates for easy traceability.
- Supplied with sealed tapered bearings for extended product life and faster line speeds.
- Safety factor 4:1
- Manufactured by an API Q1 Certified facility.

Oilfield Hoist Block

| Item No. | Sheave Dia. | Bearing Type | Wire Rope Size | Working Load Limit | N.W. | |
|---------------|-------------|--------------|----------------|--------------------|------|----|
| | inch | | mm | t* | lbs | kg |
| 8-591-0408 | 8 | TB | 10-13 | 4 | 35 | 16 |
| 8-591-0810-13 | 10 | TB | 10-13 | 8 | 55 | 25 |
| 8-591-0810-15 | 10 | TB | 13-15 | 8 | 55 | 25 |
| 8-591-1214-16 | 14 | TB | 16 | 12 | 95 | 43 |
| 8-591-1214-19 | 14 | TB | 19 | 12 | 95 | 43 |

*Minimum Ultimate Load is 4 times the Working Load Limit.

TB=Tapered Bearing





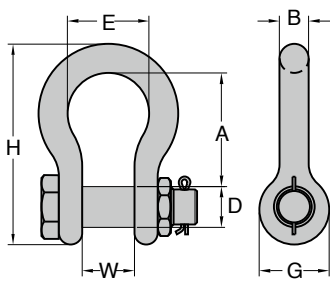

- Shackles are Type Approved by DNV & ABS.
- Shackles are forged alloy steel with alloy pin.
- Size and the Working Load Limit permanently shown on each shackle.
- All shackles with Batch Code which links to Test Certificate and quality traceability.
- 100% magnaflux crack detection during manufacturing.
- 20,000 cycle fatigue rated to 1.5 times Working Load Limit.
- Galvanized finish.

YOKE 8-808 Bolt Type Anchor Shackles meet the performance requirements of Federal Specification RR-C-271F, Type 4A, Grade B, Class 3.

Type Approval



Forged Alloy Anchor Shackle

with Bolt Pin

| Item No. | Nominal Size | Working Load Limit | Dimensions (inch) | | | | | | | N.W. |
|----------|--------------|--------------------|-------------------|---------|------|------|------|-------|------|------|
| | | | inch | tonnes* | A | B | D | E | G | |
| 8-808-08 | 5/16 | 1.2 | 1.22 | 0.31 | 0.37 | 0.82 | 0.75 | 2.13 | 0.47 | 0.2 |
| 8-808-10 | 3/8 | 2 | 1.42 | 0.39 | 0.43 | 1.02 | 0.91 | 2.56 | 0.63 | 0.2 |
| 8-808-11 | 7/16 | 2.7 | 1.70 | 0.43 | 0.51 | 1.18 | 1.06 | 2.95 | 0.75 | 0.4 |
| 8-808-13 | 1/2 | 3.3 | 1.85 | 0.52 | 0.63 | 1.30 | 1.18 | 3.34 | 0.79 | 0.7 |
| 8-808-16 | 5/8 | 5 | 2.40 | 0.63 | 0.75 | 1.77 | 1.53 | 4.21 | 1.06 | 1.5 |
| 8-808-19 | 3/4 | 7 | 2.83 | 0.75 | 0.87 | 1.97 | 1.81 | 5.04 | 1.30 | 2.2 |
| 8-808-22 | 7/8 | 9.5 | 3.39 | 0.87 | 1.02 | 2.28 | 2.09 | 5.91 | 1.50 | 3.7 |
| 8-808-26 | 1 | 12.5 | 3.78 | 1.02 | 1.10 | 2.68 | 2.36 | 6.57 | 1.73 | 5.3 |
| 8-808-28 | 1 1/8 | 15 | 4.37 | 1.10 | 1.26 | 2.91 | 2.68 | 7.52 | 1.81 | 7.5 |
| 8-808-32 | 1 1/4 | 18 | 4.76 | 1.26 | 1.42 | 3.22 | 2.99 | 8.07 | 2.12 | 10.6 |
| 8-808-36 | 1 3/8 | 21 | 5.28 | 1.42 | 1.50 | 3.62 | 3.31 | 9.13 | 2.32 | 14.3 |
| 8-808-38 | 1 1/2 | 30 | 5.57 | 1.50 | 1.77 | 3.90 | 3.62 | 10.00 | 2.36 | 19.1 |
| 8-808-45 | 1 3/4 | 40 | 7.00 | 1.85 | 2.00 | 5.00 | 4.17 | 12.32 | 2.87 | 38.5 |
| 8-808-50 | 2 | 55 | 7.76 | 2.09 | 2.24 | 5.75 | 4.80 | 13.66 | 3.27 | 53.2 |

| Item No. | Nominal Size | Working Load Limit | Dimensions (mm) | | | | | | | N.W. |
|----------|--------------|--------------------|-----------------|---------|-----|-----|-----|-----|----|------|
| | | | mm | tonnes* | A | B | D | E | G | |
| 8-808-08 | 8 | 1.2 | 31 | 8 | 9.5 | 21 | 19 | 54 | 13 | 0.1 |
| 8-808-10 | 10 | 2 | 36 | 10 | 11 | 26 | 23 | 65 | 16 | 0.1 |
| 8-808-11 | 11 | 2.7 | 43 | 11 | 13 | 30 | 27 | 75 | 19 | 0.2 |
| 8-808-13 | 13 | 3.3 | 47 | 13 | 16 | 33 | 30 | 85 | 20 | 0.3 |
| 8-808-16 | 16 | 5 | 61 | 16 | 19 | 43 | 39 | 107 | 27 | 0.7 |
| 8-808-19 | 19 | 7 | 72 | 19 | 22 | 50 | 46 | 126 | 33 | 1.0 |
| 8-808-22 | 22 | 9.5 | 86 | 22 | 26 | 58 | 53 | 148 | 38 | 1.7 |
| 8-808-26 | 26 | 12.5 | 96 | 26 | 28 | 68 | 60 | 166 | 44 | 2.4 |
| 8-808-28 | 28 | 15 | 111 | 28 | 32 | 74 | 68 | 190 | 46 | 3.4 |
| 8-808-32 | 32 | 18 | 121 | 32 | 36 | 82 | 76 | 210 | 54 | 4.8 |
| 8-808-36 | 36 | 21 | 134 | 36 | 38 | 92 | 84 | 232 | 59 | 6.5 |
| 8-808-38 | 38 | 30 | 146 | 38 | 45 | 99 | 92 | 254 | 60 | 8.7 |
| 8-808-45 | 45 | 40 | 178 | 47 | 51 | 127 | 106 | 313 | 73 | 17.5 |
| 8-808-50 | 50 | 55 | 197 | 53 | 57 | 146 | 122 | 347 | 83 | 24.2 |

★ Minimum Ultimate Load is 5 times the Working Load Limit.
 Maximum Proof Load is 2 times the Working Load Limit.

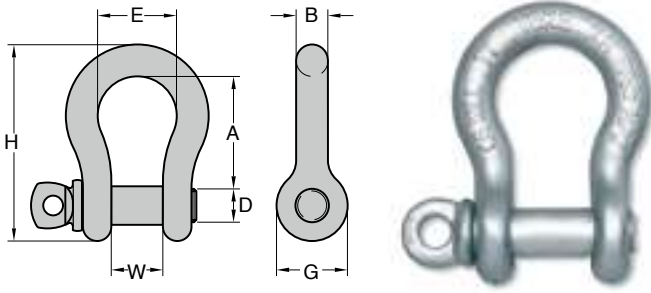

- Shackles are Type Approved by DNV & ABS.
- Shackles are forged alloy steel with alloy pin.
- Size and the Working Load Limit permanently shown on each shackle.
- All shackles with Batch Code which links to Test Certificate and quality traceability.
- 100% magnaflux crack detection during manufacturing.
- 20,000 cycle fatigue rated to 1.5 times Working Load Limit.
- Galvanized finish.

YOKE 8-807 Screw Pin Anchor Shackles meet the performance requirements of Federal Specification RR-C-271F, Type 4A, Grade B, Class 2.

Type Approval



Forged Alloy Anchor shackle

with Screw Pin

| Item No. | Nominal Size | Working Load Limit tonnes* | Dimensions (inch) | | | | | | | N.W. lbs |
|----------|--------------|-------------------------------|-------------------|------|------|------|------|------|------|-------------|
| | inch | | A | B | D | E | G | H | W | |
| 8-807-08 | 5/16 | 1.2 | 1.22 | 0.31 | 0.37 | 0.83 | 0.75 | 2.13 | 0.47 | 0.2 |
| 8-807-10 | 3/8 | 2 | 1.42 | 0.39 | 0.43 | 1.02 | 0.91 | 2.56 | 0.63 | 0.2 |
| 8-807-11 | 7/16 | 2.7 | 1.70 | 0.43 | 0.51 | 1.18 | 1.06 | 2.95 | 0.75 | 0.4 |
| 8-807-13 | 1/2 | 3.3 | 1.85 | 0.52 | 0.63 | 1.30 | 1.18 | 3.34 | 0.79 | 0.7 |
| 8-807-16 | 5/8 | 5 | 2.40 | 0.63 | 0.75 | 1.77 | 1.53 | 4.21 | 1.06 | 1.3 |
| 8-807-19 | 3/4 | 7 | 2.83 | 0.75 | 0.87 | 1.97 | 1.81 | 4.96 | 1.30 | 2.2 |
| 8-807-22 | 7/8 | 9.5 | 3.39 | 0.87 | 1.02 | 2.28 | 2.09 | 5.82 | 1.50 | 3.3 |
| 8-807-26 | 1 | 12.5 | 3.78 | 1.02 | 1.10 | 2.68 | 2.36 | 6.53 | 1.73 | 5.1 |
| 8-807-28 | 1 1/8 | 15 | 4.37 | 1.10 | 1.26 | 2.91 | 2.68 | 7.48 | 1.81 | 7.0 |
| 8-807-32 | 1 1/4 | 18 | 4.76 | 1.26 | 1.42 | 3.22 | 2.99 | 8.26 | 2.12 | 9.7 |
| 8-807-36 | 1 3/8 | 21 | 5.28 | 1.42 | 1.50 | 3.62 | 3.31 | 9.13 | 2.32 | 13.2 |

| Item No. | Nominal Size | Working Load Limit tonnes* | Dimensions (mm) | | | | | | | N.W. kg |
|----------|--------------|-------------------------------|-----------------|----|-----|----|----|-----|----|------------|
| | mm | | A | B | D | E | G | H | W | |
| 8-807-08 | 8 | 1.2 | 31 | 8 | 9.5 | 21 | 19 | 54 | 12 | 0.1 |
| 8-807-10 | 10 | 2 | 36 | 10 | 11 | 26 | 23 | 65 | 16 | 0.1 |
| 8-807-11 | 11 | 2.7 | 43 | 11 | 13 | 30 | 27 | 75 | 19 | 0.2 |
| 8-807-13 | 13 | 3.3 | 47 | 13 | 16 | 33 | 30 | 85 | 20 | 0.3 |
| 8-807-16 | 16 | 5 | 61 | 16 | 19 | 43 | 39 | 107 | 27 | 0.6 |
| 8-807-19 | 19 | 7 | 72 | 19 | 22 | 50 | 46 | 126 | 33 | 1.0 |
| 8-807-22 | 22 | 9.5 | 86 | 22 | 26 | 58 | 53 | 148 | 38 | 1.5 |
| 8-807-26 | 26 | 12.5 | 96 | 26 | 28 | 68 | 60 | 166 | 44 | 2.3 |
| 8-807-28 | 28 | 15 | 111 | 28 | 32 | 74 | 68 | 190 | 46 | 3.2 |
| 8-807-32 | 32 | 18 | 121 | 32 | 36 | 84 | 76 | 210 | 54 | 4.4 |
| 8-807-36 | 36 | 21 | 134 | 36 | 38 | 92 | 84 | 232 | 59 | 6.0 |

★ Minimum Ultimate Load is 5 times the Working Load Limit.
 Maximun Proof Load is 2 times the Working Load Limit.

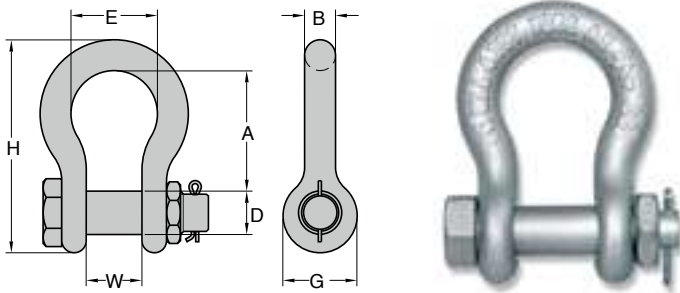

- Shackles are Type Approved by DNV & ABS.
- Shackles are forged carbon steel with alloy pin.
- Size and the Working Load Limit permanently shown on each shackle.
- All shackles with Batch Code which links to Test Certificate and quality traceability.
- 100% magnaflux crack detection during manufacturing.
- 20,000 cycle fatigue rated to 1.5 times Working Load Limit.
- Galvanized finish.

YOKE 8-838 Carbon Bolt Type Anchor Shackles meet the performance requirements of Federal Specification RR-C-271F, Type 4A, Grade A, Class 3.

Type Approval



Forged Anchor Shackle

with Bolt Pin. Carbon Steel

| Item No. | Nominal Size | Working Load Limit | Dimensions (inch) | | | | | | | N.W. |
|----------|--------------|--------------------|-------------------|---------|------|------|------|-------|------|------|
| | | | inch | tonnes* | A | B | D | E | G | |
| 8-838-08 | 5/16 | 0.75 | 1.22 | 0.31 | 0.37 | 0.82 | 0.75 | 2.13 | 0.47 | 0.2 |
| 8-838-10 | 3/8 | 1 | 1.42 | 0.39 | 0.43 | 1.02 | 0.91 | 2.56 | 0.63 | 0.2 |
| 8-838-11 | 7/16 | 1.5 | 1.70 | 0.43 | 0.51 | 1.18 | 1.06 | 2.95 | 0.75 | 0.4 |
| 8-838-13 | 1/2 | 2 | 1.85 | 0.52 | 0.63 | 1.30 | 1.18 | 3.34 | 0.79 | 0.9 |
| 8-838-16 | 5/8 | 3.25 | 2.40 | 0.63 | 0.75 | 1.70 | 1.50 | 4.17 | 1.06 | 1.5 |
| 8-838-19 | 3/4 | 4.75 | 2.83 | 0.75 | 0.87 | 1.97 | 1.81 | 5.04 | 1.30 | 2.2 |
| 8-838-22 | 7/8 | 6.5 | 3.39 | 0.87 | 1.02 | 2.28 | 2.09 | 5.91 | 1.50 | 3.7 |
| 8-838-26 | 1 | 8.5 | 3.78 | 1.02 | 1.10 | 2.68 | 2.40 | 6.57 | 1.73 | 5.3 |
| 8-838-28 | 1 1/8 | 9.5 | 4.37 | 1.10 | 1.26 | 2.91 | 2.68 | 7.52 | 1.81 | 7.5 |
| 8-838-32 | 1 1/4 | 12 | 4.76 | 1.26 | 1.42 | 3.30 | 2.99 | 8.07 | 2.12 | 10.6 |
| 8-838-36 | 1 3/8 | 13.5 | 5.28 | 1.42 | 1.50 | 3.62 | 3.31 | 9.13 | 2.32 | 14.3 |
| 8-838-38 | 1 1/2 | 17 | 5.57 | 1.50 | 1.77 | 3.90 | 3.62 | 10.00 | 2.36 | 19.4 |
| 8-838-45 | 1 3/4 | 25 | 7.00 | 1.85 | 2.00 | 5.00 | 4.17 | 12.32 | 2.87 | 38.5 |
| 8-838-50 | 2 | 35 | 7.76 | 2.09 | 2.24 | 5.75 | 4.80 | 13.66 | 3.27 | 53.2 |

| Item No. | Nominal Size | Working Load Limit | Dimensions (mm) | | | | | | | N.W. |
|----------|--------------|--------------------|-----------------|---------|-----|-----|-----|-----|----|------|
| | | | mm | tonnes* | A | B | D | E | G | |
| 8-838-08 | 8 | 0.75 | 31 | 8 | 9.5 | 21 | 19 | 54 | 12 | 0.1 |
| 8-838-10 | 10 | 1 | 36 | 10 | 11 | 26 | 23 | 65 | 16 | 0.1 |
| 8-838-11 | 11 | 1.5 | 43 | 11 | 13 | 30 | 27 | 75 | 19 | 0.2 |
| 8-838-13 | 13 | 2 | 47 | 13 | 16 | 33 | 30 | 85 | 20 | 0.4 |
| 8-838-16 | 16 | 3.25 | 61 | 16 | 19 | 43 | 38 | 106 | 27 | 0.7 |
| 8-838-19 | 19 | 4.75 | 72 | 19 | 22 | 50 | 46 | 126 | 33 | 1.0 |
| 8-838-22 | 22 | 6.5 | 86 | 22 | 26 | 58 | 53 | 148 | 38 | 1.7 |
| 8-838-26 | 26 | 8.5 | 96 | 26 | 28 | 68 | 61 | 166 | 44 | 2.4 |
| 8-838-28 | 28 | 9.5 | 111 | 28 | 32 | 74 | 68 | 190 | 46 | 3.4 |
| 8-838-32 | 32 | 12 | 121 | 32 | 36 | 84 | 76 | 210 | 54 | 4.8 |
| 8-838-36 | 36 | 13.5 | 134 | 36 | 38 | 92 | 84 | 232 | 59 | 6.5 |
| 8-838-38 | 38 | 17 | 146 | 38 | 45 | 99 | 92 | 254 | 60 | 8.8 |
| 8-838-45 | 45 | 25 | 178 | 47 | 51 | 127 | 106 | 313 | 73 | 17.5 |
| 8-838-50 | 50 | 35 | 197 | 53 | 57 | 146 | 122 | 347 | 83 | 24.2 |

★ Minimum Ultimate Load is 6 times the Working Load Limit.
 Maximum Proof Load is 2 times the Working Load Limit.

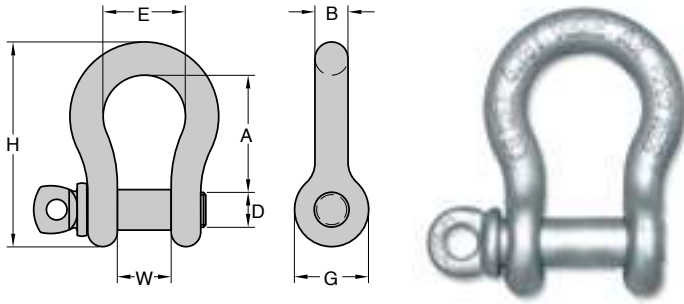

- Shackles are Type Approved by DNV & ABS.
- Shackles are forged carbon steel with alloy pin.
- Size and the Working Load Limit permanently shown on each shackle.
- All shackles with Batch Code which links to Test Certificate and quality traceability.
- 100% magnaflux crack detection during manufacturing.
- 20,000 cycle fatigue rated to 1.5 times Working Load Limit.
- Galvanized finish.

YOKE 8-837 Carbon Bolt Type Anchor Shackles meet the performance requirements of Federal Specification RR-C-271F, Type 4A, Grade A, Class 2.

Type Approval



Forged Anchor Shackle

with Screw Pin. Carbon Steel

| Item No. | Nominal Size | Working Load Limit tonnes* | Dimensions (inch) | | | | | | | N.W. lbs |
|----------|--------------|-------------------------------|-------------------|------|------|------|------|-------|------|-------------|
| | inch | | A | B | D | E | G | H | W | |
| 8-837-05 | 3/16 | 0.3 | 0.87 | 0.2 | 0.25 | 0.69 | 0.57 | 1.48 | 0.38 | 0.05 |
| 8-837-06 | 1/4 | 0.5 | 1.10 | 0.26 | 0.32 | 0.80 | 0.63 | 1.85 | 0.47 | 0.1 |
| 8-837-08 | 5/16 | 0.75 | 1.22 | 0.31 | 0.37 | 0.82 | 0.75 | 2.13 | 0.47 | 0.2 |
| 8-837-10 | 3/8 | 1 | 1.42 | 0.39 | 0.43 | 1.02 | 0.91 | 2.56 | 0.63 | 0.2 |
| 8-837-11 | 7/16 | 1.5 | 1.70 | 0.43 | 0.51 | 1.18 | 1.06 | 2.95 | 0.75 | 0.4 |
| 8-837-13 | 1/2 | 2 | 1.85 | 0.52 | 0.63 | 1.30 | 1.18 | 3.34 | 0.79 | 0.7 |
| 8-837-16 | 5/8 | 3.25 | 2.40 | 0.63 | 0.75 | 1.70 | 1.50 | 4.17 | 1.06 | 1.3 |
| 8-837-19 | 3/4 | 4.75 | 2.83 | 0.75 | 0.87 | 1.96 | 1.81 | 5.04 | 1.30 | 2.2 |
| 8-837-22 | 7/8 | 6.5 | 3.39 | 0.87 | 1.02 | 2.28 | 2.08 | 5.91 | 1.50 | 3.3 |
| 8-837-26 | 1 | 8.5 | 3.78 | 1.02 | 1.10 | 2.68 | 2.67 | 6.57 | 1.73 | 5.1 |
| 8-837-28 | 1 1/8 | 9.5 | 4.37 | 1.10 | 1.26 | 2.91 | 2.68 | 7.52 | 1.81 | 7.0 |
| 8-837-32 | 1 1/4 | 12 | 4.76 | 1.26 | 1.42 | 3.30 | 2.99 | 8.07 | 2.12 | 9.9 |
| 8-837-36 | 1 3/8 | 13.5 | 5.28 | 1.42 | 1.50 | 3.62 | 3.30 | 9.13 | 2.32 | 13.9 |
| 8-837-38 | 1 1/2 | 17 | 5.75 | 1.50 | 1.77 | 3.90 | 3.62 | 10.00 | 2.36 | 17.8 |
| 8-837-45 | 1 3/4 | 25 | 7.00 | 1.85 | 2.00 | 5.00 | 4.17 | 12.32 | 2.87 | 35.9 |
| 8-837-50 | 2 | 35 | 7.76 | 2.09 | 2.24 | 5.75 | 4.80 | 13.66 | 3.27 | 51.0 |

| Item No. | Nominal Size | Working Load Limit tonnes* | Dimensions (mm) | | | | | | | N.W. kg |
|----------|--------------|-------------------------------|-----------------|-----|-----|-----|-----|-----|----|------------|
| | mm | | A | B | D | E | G | H | W | |
| 8-837-05 | 5 | 0.3 | 22 | 5 | 6 | 17 | 15 | 38 | 10 | 0.021 |
| 8-837-06 | 6 | 0.5 | 28 | 6.5 | 8 | 20 | 16 | 47 | 12 | 0.05 |
| 8-837-08 | 8 | 0.75 | 31 | 8 | 9.5 | 21 | 19 | 54 | 12 | 0.1 |
| 8-837-10 | 10 | 1 | 36 | 10 | 11 | 26 | 23 | 65 | 16 | 0.1 |
| 8-837-11 | 11 | 1.5 | 43 | 11 | 13 | 30 | 27 | 75 | 19 | 0.2 |
| 8-837-13 | 13 | 2 | 47 | 13 | 16 | 33 | 30 | 85 | 20 | 0.3 |
| 8-837-16 | 16 | 3.25 | 61 | 16 | 19 | 43 | 38 | 106 | 27 | 0.6 |
| 8-837-19 | 19 | 4.75 | 72 | 19 | 22 | 50 | 46 | 126 | 33 | 1.0 |
| 8-837-22 | 22 | 6.5 | 86 | 22 | 26 | 58 | 53 | 148 | 38 | 1.5 |
| 8-837-26 | 26 | 8.5 | 96 | 26 | 28 | 69 | 61 | 166 | 44 | 2.3 |
| 8-837-28 | 28 | 9.5 | 111 | 28 | 32 | 74 | 68 | 190 | 46 | 3.2 |
| 8-837-32 | 32 | 12 | 121 | 32 | 36 | 84 | 76 | 210 | 54 | 4.5 |
| 8-837-36 | 36 | 13.5 | 134 | 36 | 38 | 92 | 84 | 232 | 59 | 6.3 |
| 8-837-38 | 38 | 17 | 146 | 38 | 45 | 99 | 92 | 254 | 60 | 8.1 |
| 8-837-45 | 45 | 25 | 178 | 47 | 51 | 127 | 106 | 313 | 73 | 16.3 |
| 8-837-50 | 50 | 35 | 197 | 53 | 57 | 146 | 122 | 347 | 83 | 23.2 |

★ Minimum Ultimate Load is 6 times the Working Load Limit.
 Maximum Proof Load is 2 times the Working Load Limit.



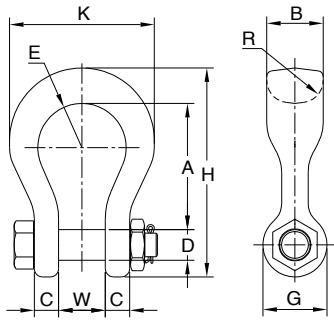

Fig. 1

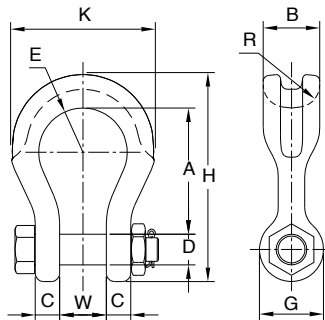

Fig. 2



- Shackles are forged alloy steel with alloy pin.
- Size and the Working Load Limit permanently shown on each shackle.
- All shackles with Batch Code which links to Test Certificate and quality traceability.
- 100% magnaflux crack detection during manufacturing.
- 20,000 cycle fatigue rated to 1.5 times Working Load Limit.
- Galvanized finish.

Forged Alloy Wide Body Shackle

with Bolt Pin

| Item No. | Nominal Size | Working Load Limit | Dimensions (inch) | | | | | | | | | | N.W. |
|----------|--------------|--------------------|-------------------|------|------|------|------|------|-------|------|------|------|------|
| | inch | | tonnes* | A | B | C | D | E | G | H | K | R | |
| 8-809-19 | 3/4 | 7 | 3.58 | 1.61 | 0.70 | 0.87 | 1.26 | 1.81 | 5.90 | 4.09 | 1.26 | 1.30 | 3.7 |
| 8-809-26 | 1 | 12.5 | 4.64 | 2.12 | 0.91 | 1.14 | 1.61 | 2.40 | 7.64 | 5.51 | 1.38 | 1.73 | 8.4 |
| 8-809-32 | 1 1/4 | 18 | 5.83 | 2.52 | 1.18 | 1.42 | 2.00 | 2.68 | 9.37 | 6.77 | 1.50 | 2.13 | 14.7 |
| 8-809-38 | 1 1/2 | 30 | 6.93 | 3.15 | 1.38 | 1.77 | 2.50 | 3.50 | 11.38 | 8.50 | 1.77 | 2.36 | 27.5 |

★ Minimum Ultimate Load is 5 times the Working Load Limit.

Maximun Proof Load is 2 times the Working Load Limit.

★ 8-809-19/-26 See Figure 1

★ 8-809-32/-38 See Figure 2

| Item No. | Nominal Size | Working Load Limit | Dimensions (mm) | | | | | | | | | | N.W. |
|----------|--------------|--------------------|-----------------|----|----|----|----|----|-----|-----|----|----|------|
| | mm | | tonnes* | A | B | C | D | E | G | H | K | R | |
| 8-809-19 | 19 | 7 | 91 | 41 | 18 | 22 | 32 | 46 | 150 | 104 | 32 | 33 | 1.7 |
| 8-809-26 | 26 | 12.5 | 118 | 54 | 23 | 29 | 41 | 61 | 194 | 140 | 35 | 44 | 3.8 |
| 8-809-32 | 32 | 18 | 148 | 64 | 30 | 36 | 51 | 68 | 238 | 172 | 38 | 54 | 6.7 |
| 8-809-38 | 38 | 30 | 176 | 80 | 35 | 45 | 64 | 89 | 289 | 216 | 45 | 60 | 12.5 |

★ Minimum Ultimate Load is 5 times the Working Load Limit.

Maximun Proof Load is 2 times the Working Load Limit.

Forged Alloy Chain Shackle

with Bolt Pin

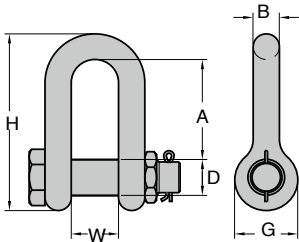

YOKE 8-805 Bolt Type Chain Shackles meet the performance requirements of Federal Specification RR-C-271F, Type 4B, Grade B, Class 3.

- Shackles are Type Approved by ABS.
- Shackles are forged alloy steel with alloy pin.
- Size and the Working Load Limit permanently shown on each shackle.
- All shackles with Batch Code which links to Test Certificate and quality traceability.
- 100% magnaflux crack detection during manufacturing.
- 20,000 cycle fatigue rated to 1.5 times Working Load Limit.
- Galvanized finish.

| Item No. | Nominal Size | Working Load Limit tonnes* | Dimensions (mm) | | | | | | N.W. kg |
|----------|--------------|-------------------------------|-----------------|----|----|----|-----|----|------------|
| | inch | | A | B | D | G | H | W | |
| 8-805-16 | 5/8 | 5 | 60 | 16 | 19 | 38 | 106 | 27 | 0.6 |
| 8-805-19 | 3/4 | 7 | 71 | 19 | 22 | 46 | 126 | 33 | 1.0 |
| 8-805-22 | 7/8 | 9.5 | 87 | 22 | 26 | 53 | 148 | 38 | 1.6 |
| 8-805-26 | 1 | 12.5 | 95 | 26 | 28 | 60 | 166 | 44 | 2.4 |
| 8-805-28 | 1 1/8 | 15 | 108 | 28 | 32 | 68 | 190 | 46 | 3.3 |
| 8-805-32 | 1 1/4 | 18 | 119 | 32 | 36 | 76 | 210 | 52 | 4.6 |
| 8-805-36 | 1 3/8 | 21 | 133 | 36 | 38 | 84 | 232 | 57 | 6.2 |

Type Approval



Type Approval

- ★ Minimum Ultimate Load is 5 times the Working Load Limit.
- Maximun Proof Load is 2 times the Working Load Limit.

Forged Alloy Chain Shackle

with Screw Pin

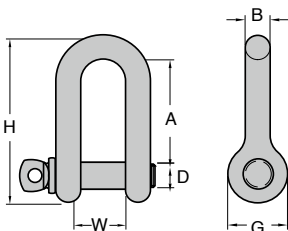

YOKE 8-804 Screw Type Chain Shackles meet the performance requirements of Federal Specification RR-C-271F, Type 4B, Grade B, Class 2.

- Shackles are Type Approved by DNV & ABS.
- Shackles are forged alloy steel with alloy pin.
- Size and the Working Load Limit permanently shown on each shackle.
- All shackles with Batch Code which links to Test Certificate and quality traceability.
- 100% magnaflux crack detection during manufacturing.
- 20,000 cycle fatigue rated to 1.5 times Working Load Limit.
- Galvanized finish.

| Item No. | Nominal Size | Working Load Limit tonnes* | Dimensions (mm) | | | | | | N.W. kg |
|----------|--------------|-------------------------------|-----------------|----|-----|----|-----|----|------------|
| | inch | | A | B | D | G | H | W | |
| 8-804-08 | 5/16 | 1.2 | 31 | 8 | 9.5 | 19 | 52 | 13 | 0.1 |
| 8-804-10 | 3/8 | 2 | 36 | 10 | 11 | 23 | 63 | 16 | 0.1 |
| 8-804-11 | 7/16 | 2.7 | 43 | 11 | 13 | 27 | 74 | 19 | 0.2 |
| 8-804-13 | 1/2 | 3.3 | 47 | 13 | 16 | 30 | 83 | 20 | 0.3 |
| 8-804-16 | 5/8 | 5 | 60 | 16 | 19 | 38 | 106 | 27 | 0.6 |
| 8-804-19 | 3/4 | 7 | 71 | 19 | 22 | 46 | 126 | 33 | 0.9 |
| 8-804-22 | 7/8 | 9.5 | 87 | 22 | 26 | 53 | 148 | 38 | 1.4 |
| 8-804-26 | 1 | 12.5 | 95 | 26 | 28 | 60 | 166 | 44 | 2.2 |
| 8-804-28 | 1 1/8 | 15 | 108 | 28 | 32 | 68 | 190 | 46 | 3.0 |
| 8-804-32 | 1 1/4 | 18 | 119 | 32 | 36 | 76 | 210 | 52 | 4.2 |
| 8-804-36 | 1 3/8 | 21 | 133 | 36 | 38 | 84 | 232 | 57 | 5.7 |

Type Approval



- ★ Minimum Ultimate Load is 5 times the Working Load Limit.
- Maximun Proof Load is 2 times the Working Load Limit.

Forged Chain Shackle

with Bolt Pin

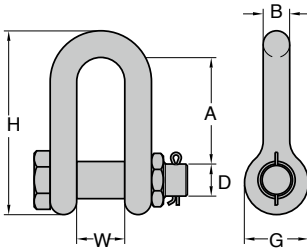

YOKE 8-835 Bolt Type Anchor Shackles meet the performance requirements of Federal Specification RR-C-271F, Type 4B, Grade A, Class 3.

Type Approval



- Shackles are Type Approved by ABS.
- Shackles are forged carbon steel with alloy pin.
- Size and the Working Load Limit permanently shown on each shackle.
- All shackles with Batch Code which links to Test Certificate and quality traceability.
- 100% magnaflux crack detection during manufacturing.
- 20,000 cycle fatigue rated to 1.5 times Working Load Limit.
- Galvanized finish.

| Item No. | Nominal Size | Working Load Limit | Dimensions (mm) | | | | | | N.W. |
|----------|--------------|--------------------|-----------------|----|-----|----|-----|----|------|
| | inch | | tonnes* | A | B | D | G | H | W |
| 8-835-08 | 5/16 | 0.75 | 31 | 8 | 9.5 | 19 | 52 | 13 | 0.1 |
| 8-835-10 | 3/8 | 1 | 36 | 10 | 11 | 23 | 63 | 16 | 0.1 |
| 8-835-11 | 7/16 | 1.5 | 43 | 11 | 13 | 27 | 74 | 19 | 0.2 |
| 8-835-13 | 1/2 | 2 | 57 | 13 | 16 | 30 | 83 | 20 | 0.3 |
| 8-835-16 | 5/8 | 3.25 | 60 | 16 | 19 | 38 | 106 | 27 | 0.6 |
| 8-835-19 | 3/4 | 4.75 | 71 | 19 | 22 | 46 | 126 | 33 | 1.0 |
| 8-835-22 | 7/8 | 6.5 | 87 | 22 | 26 | 53 | 148 | 38 | 1.6 |
| 8-835-26 | 1 | 8.5 | 95 | 26 | 28 | 60 | 166 | 44 | 2.4 |
| 8-835-28 | 1 1/8 | 9.5 | 108 | 28 | 32 | 68 | 190 | 46 | 3.2 |
| 8-835-32 | 1 1/4 | 12 | 119 | 32 | 36 | 76 | 210 | 52 | 4.5 |
| 8-835-36 | 1 3/8 | 13.5 | 133 | 36 | 38 | 84 | 232 | 57 | 6.1 |

★ Minimum Ultimate Load is 6 times the Working Load Limit.
 Maximum Proof Load is 2 times the Working Load Limit.

Forged Chain Shackle

with Screw Pin

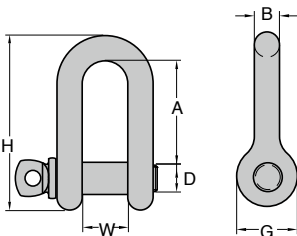

YOKE 8-834 Screw Pin Chain Shackles meet the performance requirements of Federal Specification RR-C-271F, Type 4B, Grade A, Class 2.

Type Approval



- Shackles are Type Approved by ABS.
- Shackles are forged carbon steel with alloy pin.
- Size and the Working Load Limit permanently shown on each shackle.
- All shackles with Batch Code which links to Test Certificate and quality traceability.
- 100% magnaflux crack detection during manufacturing.
- 20,000 cycle fatigue rated to 1.5 times Working Load Limit.
- Galvanized finish.

| Item No. | Nominal Size | Working Load Limit | Dimensions (mm) | | | | | | N.W. |
|----------|--------------|--------------------|-----------------|----|-----|----|-----|----|------|
| | inch | | tonnes* | A | B | D | G | H | W |
| 8-834-08 | 5/16 | 0.75 | 31 | 8 | 9.5 | 19 | 52 | 13 | 0.1 |
| 8-834-10 | 3/8 | 1 | 36 | 10 | 11 | 23 | 63 | 16 | 0.1 |
| 8-834-11 | 7/16 | 1.5 | 43 | 11 | 13 | 27 | 74 | 19 | 0.2 |
| 8-834-13 | 1/2 | 2 | 57 | 13 | 16 | 30 | 83 | 20 | 0.3 |
| 8-834-16 | 5/8 | 3.25 | 51 | 16 | 19 | 38 | 96 | 27 | 0.6 |
| 8-834-19 | 3/4 | 4.75 | 71 | 19 | 22 | 46 | 126 | 33 | 1.0 |
| 8-834-22 | 7/8 | 6.5 | 87 | 22 | 26 | 53 | 148 | 38 | 1.5 |
| 8-834-26 | 1 | 8.5 | 95 | 26 | 28 | 60 | 166 | 44 | 2.2 |
| 8-834-28 | 1 1/8 | 9.5 | 108 | 28 | 32 | 68 | 190 | 46 | 3.0 |
| 8-834-32 | 1 1/4 | 12 | 100 | 32 | 36 | 76 | 188 | 52 | 4.2 |
| 8-834-36 | 1 3/8 | 13.5 | 115 | 36 | 38 | 84 | 212 | 57 | 5.7 |

★ Minimum Ultimate Load is 6 times the Working Load Limit.
 Maximum Proof Load is 2 times the Working Load Limit.



Wire Rope Clip

- Galvanized finish.
- Forged base for full range of sizes.
- According to the breaking load of the wire rope, YOKE wire rope clips have an efficiency rating of 80% for 1/8" - 7/8" sizes, and 90% for sizes 1" up to 3".
- Manufactured with or exceeds all requirements of ASME B30.26 and EN13411 -2003.

Yoke Wire Rope Clip in accordance with FF-C-450 TYPE 1 CLASS 1 and EN13411-2003.

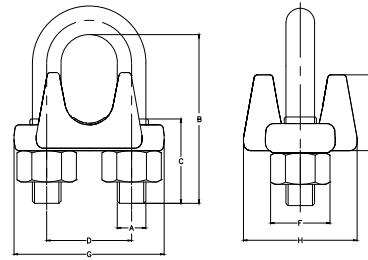

Wire Rope Clip by Imperial

| Item No. | Size | | Dimension(inch) | | | | | | | | N.W lbs |
|----------|-------|-------|-----------------|------|------|------|------|------|------|------|------------|
| | mm | inch | A | B | C | D | E | F | G | H | |
| 8-762-03 | 3-4 | 1/8 | 0.20 | 0.98 | 0.47 | 0.47 | 0.39 | 0.35 | 1.02 | 0.83 | 0.06 |
| 8-762-05 | 5 | 3/16 | 0.20 | 1.18 | 0.55 | 0.59 | 0.51 | 0.51 | 1.22 | 0.98 | 0.09 |
| 8-762-06 | 6-7 | 1/4 | 0.28 | 1.30 | 0.59 | 0.75 | 0.67 | 0.55 | 1.46 | 1.22 | 0.19 |
| 8-762-08 | 8 | 5/16 | 0.31 | 1.38 | 0.75 | 0.87 | 0.75 | 0.67 | 1.69 | 1.34 | 0.31 |
| 8-762-10 | 9-10 | 3/8 | 0.35 | 1.50 | 0.75 | 0.98 | 0.94 | 0.75 | 2.01 | 1.65 | 0.51 |
| 8-762-11 | 11 | 7/16 | 0.43 | 1.89 | 0.98 | 1.18 | 1.14 | 0.87 | 2.32 | 1.93 | 0.81 |
| 8-762-13 | 12-13 | 1/2 | 0.43 | 1.89 | 0.98 | 1.18 | 1.14 | 0.87 | 2.28 | 1.93 | 0.81 |
| 8-762-14 | 14-15 | 9/16 | 0.51 | 2.40 | 1.26 | 1.30 | 1.22 | 0.94 | 2.52 | 2.09 | 1.06 |
| 8-762-16 | 16 | 5/8 | 0.51 | 2.40 | 1.26 | 1.30 | 1.38 | 0.94 | 2.52 | 2.05 | 1.06 |
| 8-762-19 | 18-20 | 3/4 | 0.55 | 2.76 | 1.46 | 1.50 | 1.38 | 1.06 | 2.83 | 2.24 | 1.50 |
| 8-762-22 | 22 | 7/8 | 0.67 | 3.11 | 1.61 | 1.77 | 1.50 | 1.26 | 3.19 | 2.44 | 2.20 |
| 8-762-26 | 24-26 | 1 | 0.67 | 3.50 | 1.81 | 1.89 | 1.69 | 1.26 | 3.50 | 2.64 | 2.66 |
| 8-762-28 | 28-30 | 1-1/8 | 0.67 | 3.90 | 2.01 | 2.01 | 1.97 | 1.26 | 3.62 | 2.83 | 2.99 |
| 8-762-32 | 32-34 | 1-1/4 | 0.79 | 4.25 | 2.13 | 2.32 | 2.17 | 1.46 | 4.13 | 3.15 | 4.58 |
| 8-762-36 | 36 | 1-3/8 | 0.79 | 4.25 | 2.13 | 2.32 | 2.28 | 1.46 | 4.17 | 3.11 | 4.91 |
| 8-762-38 | 38 | 1-1/2 | 0.79 | 4.92 | 2.40 | 2.64 | 2.40 | 1.46 | 4.45 | 3.39 | 5.46 |
| 8-762-42 | 41-42 | 1-5/8 | 0.87 | 5.31 | 2.64 | 2.76 | 2.68 | 1.61 | 4.80 | 3.58 | 7.22 |
| 8-762-45 | 44-46 | 1-3/4 | 0.94 | 5.75 | 2.76 | 3.07 | 2.99 | 1.81 | 5.28 | 3.86 | 9.42 |
| 8-762-50 | 48-52 | 2 | 1.26 | 6.46 | 2.99 | 3.39 | 3.07 | 2.01 | 5.91 | 4.45 | 13.75 |
| 8-762-57 | 56-58 | 2-1/4 | 1.26 | 7.05 | 3.66 | 3.90 | 3.23 | 2.01 | 6.54 | 4.53 | 15.62 |
| 8-762-64 | 62-65 | 2-1/2 | 1.26 | 7.60 | 3.74 | 4.13 | 3.66 | 2.01 | 6.69 | 4.72 | 17.34 |
| 8-762-70 | 68-72 | 2-3/4 | 1.26 | 8.19 | 3.82 | 4.37 | 4.13 | 2.01 | 7.01 | 4.88 | 21.03 |
| 8-762-75 | 75-78 | 3 | 1.50 | 9.13 | 4.09 | 4.72 | 4.53 | 2.40 | 7.64 | 5.31 | 32.56 |



Wire Rope Clip

- Galvanized finish.
- Forged base for full range of sizes.
- According to the breaking load of the wire rope, YOKE wire rope clips have an efficiency rating of 80% for 1/8" - 7/8" sizes, and 90% for sizes 1" up to 3".
- Manufactured with or exceeds all requirements of ASME B30.26 and EN13411 -2003.

YOKE Wire Rope Clip in accordance with FF-C-450 TYPE 1 CLASS 1 and EN13411-2003.

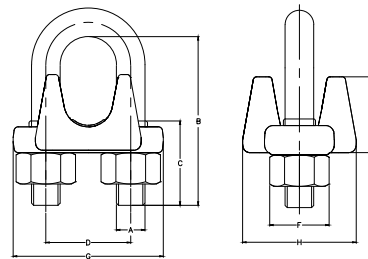

Wire Rope Clip by Metric

| Item No. | Size | | Dimension(mm) | | | | | | | | N.W kg |
|----------|-------|-------|---------------|-----|-----|-----|-----|----|-----|-----|-----------|
| | mm | inch | A | B | C | D | E | F | G | H | |
| 8-762-03 | 3-4 | 1/8 | 5 | 25 | 12 | 12 | 10 | 9 | 26 | 21 | 0.03 |
| 8-762-05 | 5 | 3/16 | 5 | 30 | 14 | 15 | 13 | 13 | 31 | 25 | 0.04 |
| 8-762-06 | 6-7 | 1/4 | 7 | 33 | 15 | 19 | 17 | 14 | 37 | 31 | 0.09 |
| 8-762-08 | 8 | 5/16 | 8 | 35 | 19 | 22 | 19 | 17 | 43 | 34 | 0.14 |
| 8-762-10 | 9-10 | 3/8 | 9 | 38 | 19 | 25 | 24 | 19 | 51 | 42 | 0.23 |
| 8-762-11 | 11 | 7/16 | 11 | 48 | 25 | 30 | 29 | 22 | 59 | 49 | 0.37 |
| 8-762-13 | 12-13 | 1/2 | 11 | 48 | 25 | 30 | 29 | 22 | 58 | 49 | 0.37 |
| 8-762-14 | 14-15 | 9/16 | 13 | 61 | 32 | 33 | 31 | 24 | 64 | 53 | 0.48 |
| 8-762-16 | 16 | 5/8 | 13 | 61 | 32 | 33 | 35 | 24 | 64 | 52 | 0.48 |
| 8-762-19 | 18-20 | 3/4 | 14 | 70 | 37 | 38 | 35 | 27 | 72 | 57 | 0.68 |
| 8-762-22 | 22 | 7/8 | 17 | 79 | 41 | 45 | 38 | 32 | 81 | 62 | 1.00 |
| 8-762-26 | 24-26 | 1 | 17 | 89 | 46 | 48 | 43 | 32 | 89 | 67 | 1.21 |
| 8-762-28 | 28-30 | 1-1/8 | 17 | 99 | 51 | 51 | 50 | 32 | 92 | 72 | 1.36 |
| 8-762-32 | 32-34 | 1-1/4 | 20 | 108 | 54 | 59 | 55 | 37 | 105 | 80 | 2.08 |
| 8-762-36 | 36 | 1-3/8 | 20 | 108 | 54 | 59 | 58 | 37 | 106 | 79 | 2.23 |
| 8-762-38 | 38 | 1-1/2 | 20 | 125 | 61 | 67 | 61 | 37 | 113 | 86 | 2.48 |
| 8-762-42 | 41-42 | 1-5/8 | 22 | 135 | 67 | 70 | 68 | 41 | 122 | 91 | 3.28 |
| 8-762-45 | 44-46 | 1-3/4 | 24 | 146 | 70 | 78 | 76 | 46 | 134 | 98 | 4.28 |
| 8-762-50 | 48-52 | 2 | 32 | 164 | 76 | 86 | 78 | 51 | 150 | 113 | 6.25 |
| 8-762-57 | 56-58 | 2-1/4 | 32 | 179 | 93 | 99 | 82 | 51 | 166 | 115 | 7.10 |
| 8-762-64 | 62-65 | 2-1/2 | 32 | 193 | 95 | 105 | 93 | 51 | 170 | 120 | 7.88 |
| 8-762-70 | 68-72 | 2-3/4 | 32 | 208 | 97 | 111 | 105 | 51 | 178 | 124 | 9.56 |
| 8-762-75 | 75-78 | 3 | 38 | 232 | 104 | 120 | 115 | 61 | 194 | 135 | 14.80 |

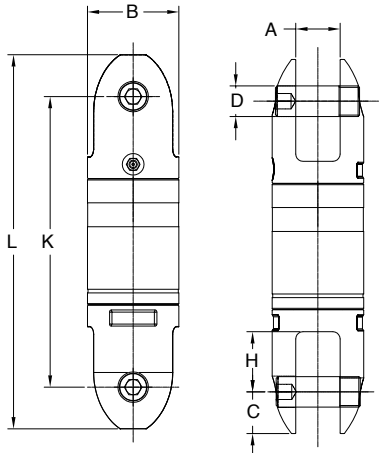

- YOKE Swivels are manufactured using the highest grade of material available.
- YOKE Swivels are designed with a safety factor of 5:1.
- YOKE Swivels are available in sizes from 3/4 Tons to 35 Tons.
- YOKE Swivels are available for wire lines 1/4" to 1-1/2".
- YOKE Swivels are zinc plated for corrosion resistance and longer life.
- YOKE Swivels are manufactured with grease fittings for superior performance.
- YOKE Swivels are designed for low starting torque and high rotation speed.
- All Swivels parts are 100% magnaflux crack detected.
- 20,000 cycle fatigue rate to 1.5 times working load limit.
- All parts with batch number for quality certified and traceability.

Angular Contact Bearing Swivels - Bullet Style

| Item No. | Wire Line Size | Working Load Limit | Dimensions (inch) | | | | | | | N.W. |
|------------|----------------|--------------------|-------------------|-------|-------|------|------|------|------|------|
| | inch | | Tons* | B | K | L | C | A | D | |
| 8-301-0075 | 1/4 | 0.75 | 1.30 | 4.00 | 5.00 | 0.50 | 0.60 | 0.40 | 0.90 | 1.1 |
| 8-301-015 | 3/8 | 1.5 | 1.60 | 4.40 | 5.70 | 0.60 | 0.70 | 0.50 | 1.00 | 1.7 |
| 8-301-03 | 1/2 | 3 | 2.00 | 6.30 | 8.00 | 0.90 | 0.90 | 0.60 | 1.20 | 4.4 |
| 8-301-05 | 5/8 | 5 | 2.50 | 8.00 | 10.30 | 1.20 | 1.30 | 0.90 | 1.50 | 8.7 |
| 8-301-085 | 3/4 | 8.5 | 3.00 | 9.50 | 12.30 | 1.40 | 1.50 | 1.00 | 2.00 | 14.8 |
| 8-301-10 | 7/8 | 10 | 4.00 | 12.50 | 16.00 | 1.80 | 1.70 | 1.50 | 2.10 | 40.0 |
| 8-301-15 | 1 | 15 | 4.30 | 12.50 | 16.00 | 1.80 | 2.00 | 1.50 | 2.20 | 46.2 |
| 8-301-25 | 1 1/4 | 25 | 5.20 | 14.70 | 19.50 | 2.40 | 2.50 | 2.00 | 2.70 | 80.5 |

★ Minimum Ultimate Load is 5 times the Working Load Limit.
 Maximun Proof Load is 2 times the Working Load Limit.

| Item No. | Wire Line Size | Working Load Limit | Dimensions (mm) | | | | | | | N.W. |
|------------|----------------|--------------------|-----------------|-----|-----|----|----|----|----|------|
| | mm | | Tons* | B | K | L | C | A | D | |
| 8-301-0075 | 6 | 0.75 | 32 | 103 | 126 | 12 | 15 | 10 | 22 | 0.5 |
| 8-301-015 | 10 | 1.5 | 40 | 112 | 144 | 16 | 18 | 11 | 26 | 0.8 |
| 8-301-03 | 13 | 3 | 51 | 159 | 203 | 23 | 23 | 16 | 31 | 2.0 |
| 8-301-05 | 16 | 5 | 64 | 200 | 262 | 31 | 32 | 22 | 37 | 4.0 |
| 8-301-085 | 19 | 8.5 | 76 | 242 | 312 | 35 | 37 | 25 | 50 | 6.7 |
| 8-301-10 | 22 | 10 | 102 | 317 | 408 | 46 | 42 | 38 | 53 | 18.2 |
| 8-301-15 | 25 | 15 | 108 | 317 | 408 | 46 | 48 | 38 | 56 | 21.0 |
| 8-301-25 | 32 | 25 | 132 | 374 | 495 | 61 | 62 | 51 | 69 | 36.5 |

★ Minimum Ultimate Load is 5 times the Working Load Limit.
 Maximun Proof Load is 2 times the Working Load Limit.



INDEX

| By Item. Number | | | | | | | | Code & Number | | | | | | | |
|-----------------|------|----------|------|----------|------|----------|------|---------------|------|------|------|------|----------|------|----------|
| Item No. | Page | Item No. | Page | Item No. | Page | Item No. | Page | Code | Page | Code | Page | Code | Item No. | Code | Item No. |
| 8-003 | 123 | 8-551 | 176 | X-175N | 103 | | | BSI | 155 | YEN | 134 | BSI | 8-088 | | |
| 8-003F | 123 | 8-552 | 177 | X-950 | 112 | | | BST | 157 | YF | 138 | BST | 8-054 | | |
| 8-015 | 124 | 8-561 | 178 | X-951 | 113 | | | DA | 131 | YG | 131 | DAA | 8-057 | | |
| 8-018 | 125 | 8-562 | 179 | X-952N | 114 | | | DAA | 65 | YH | 139 | DAB | 8-058 | | |
| 8-023 | 138 | 8-572 | 180 | X-A04 | 89 | | | DAB | 58 | YK | 139 | EB | 8-055 | | |
| 8-025 | 126 | 8-591 | 181 | X-A05 | 90 | | | DC | 150 | YL | 154 | EC | 8-051 | | |
| 8-026 | 126 | 8-762 | 191 | X-A06 | 91 | | | EA | 156 | YM | 137 | ECO | 8-052 | | |
| 8-027 | 125 | 8-804 | 189 | | | | | EB | 156 | YN | 136 | EH | 8-020 | | |
| 8-027N | 125 | 8-805 | 189 | | | | | EC | 155 | YO | 132 | EHN | 8-020N | | |
| 8-041 | 130 | 8-807 | 185 | | | | | ECO | 155 | YP | 136 | FA | 8-093 | | |
| 8-042 | 130 | 8-808 | 184 | | | | | EH | 150 | YR | 137 | FE | 8-097 | | |
| 8-043/S | 128 | 8-809 | 188 | | | | | EHN | 152 | YSW | 135 | KA | 8-067 | | |
| 8-044/S | 127 | 8-834 | 190 | | | | | EHY | 152 | YSWN | 135 | KCK | 8-061 | | |
| 8-047 | 127 | 8-835 | 190 | | | | | EHYN | 152 | YSWX | 144 | KE | 8-063 | | |
| 8-048 | 133 | 8-837 | 187 | | | | | EL | 136 | YT | 138 | KF | 8-074 | | |
| 8-049N | 129 | 8-838 | 186 | | | | | EM | 147 | YW | 156 | KP | 8-022 | | |
| 8-051 | 139 | 8-911 | 161 | | | | | EX | 142 | YX | 63 | KR | 8-064 | | |
| 8-052 | 139 | 8-921 | 162 | | | | | FA | 147 | | | KU | 8-069 | | |
| 8-053 | 140 | 8-931 | 163 | | | | | FE | 137 | | | MF | 8-003 | | |
| 8-054 | 140 | 8-S291 | 32 | | | | | FG | 146 | | | MFF | 8-003F | | |
| 8-055 | 139 | 8-S292 | 34 | | | | | FM | 150 | | | YA | 8-015 | | |
| 8-057 | 65 | DA-001 | 151 | | | | | FN | 149 | | | YC | 8-025 | | |
| 8-0573 | 64 | DA-007 | 152 | | | | | FT | 149 | | | YD | 8-026 | | |
| 8-0575 | 66 | DA-025 | 156 | | | | | KA | 143 | | | YE | 8-027 | | |
| 8-0576 | 67 | DA-027N | 155 | | | | | KB | 143 | | | YEN | 8-027N | | |
| 8-058 | 58 | DA-271 | 46 | | | | | KC | 140 | | | YG | 8-059 | | |
| 8-059 | 124 | DA-271 | 157 | | | | | KCK | 139 | | | YH | 8-041 | | |
| 8-061 | 130 | DA-272 | 48 | | | | | KD | 140 | | | YK | 8-042 | | |
| 8-063 | 134 | DA-272 | 159 | | | | | KE | 145 | | | YL | 8-023 | | |
| 8-064 | 129 | DA-808 | 154 | | | | | KF | 144 | | | YM | 8-043/S | | |
| 8-066 | 128 | DA-838 | 153 | | | | | KK | 145 | | | YN | 8-047 | | |
| 8-067 | 132 | X-001 | 77 | | | | | KL | 144 | | | YO | 8-018 | | |
| 8-074 | 133 | X-002 | 79 | | | | | KP | 135 | | | YP | 8-044/S | | |
| 8-078 | 132 | X-002W | 80 | | | | | KR | 140 | | | YR | 8-066 | | |
| 8-081 | 63 | X-003 | 85 | | | | | KT | 141 | | | YSWN | 8-049N | | |
| 8-082 | 68 | X-004 | 86 | | | | | KU | 143 | | | YSWX | 8-048 | | |
| 8-083 | 62 | X-006 | 81 | | | | | MF | 130 | | | YT | 8-075 | | |
| 8-088N | 139 | X-006L | 82 | | | | | MFF | 130 | | | YW | 8-053 | | |
| 8-093 | 133 | X-007 | 78 | | | | | YA | 132 | | | YX | 8-081 | | |
| 8-097 | 128 | X-0080 | 83 | | | | | YC | 133 | | | | | | |
| 8-123 | 134 | X-0081 | 84 | | | | | YD | 133 | | | | | | |
| 8-203 | 50 | X-009 | 87 | | | | | YE | 134 | | | | | | |
| 8-204 | 52 | X-015 | 92 | | | | | YEA | 134 | | | | | | |
| 8-211 | 16 | X-016 | 115 | | | | | | | | | | | | |
| 8-212 | 18 | X-019 | 98 | | | | | | | | | | | | |
| 8-231 | 22 | X-025 | 94 | | | | | | | | | | | | |
| 8-232 | 24 | X-026 | 95 | | | | | | | | | | | | |
| 8-251 | 37 | X-027 | 96 | | | | | | | | | | | | |
| 8-252 | 40 | X-027N | 97 | | | | | | | | | | | | |
| 8-271 | 42 | X-041 | 106 | | | | | | | | | | | | |
| 8-272 | 44 | X-042 | 107 | | | | | | | | | | | | |
| 8-281 | 56 | X-043 | 100 | | | | | | | | | | | | |
| 8-285 | 57 | X-044 | 99 | | | | | | | | | | | | |
| 8-291K | 28 | X-047 | 104 | | | | | | | | | | | | |
| 8-292K | 30 | X-059 | 116 | | | | | | | | | | | | |
| 8-301 | 193 | X-061 | 109 | | | | | | | | | | | | |
| 8-501 | 172 | X-066 | 117 | | | | | | | | | | | | |
| 8-502 | 173 | X-079 | 88 | | | | | | | | | | | | |
| 8-541 | 174 | X-173 | 101 | | | | | | | | | | | | |
| 8-542 | 175 | X-175 | 102 | | | | | | | | | | | | |



Safety is our first priority™

An ISO 9001 Registered Company

YOKE products distributed by:

YOKE INDUSTRIAL CORP.

#39, 33rd Road,
Taichung Industrial Park,
Taichung 407,
TAIWAN

Tel:+886-4-2350-8088

Fax:+886-4-2350-1001

E-mail: info@mail.yoke.net



www.yoke.net